

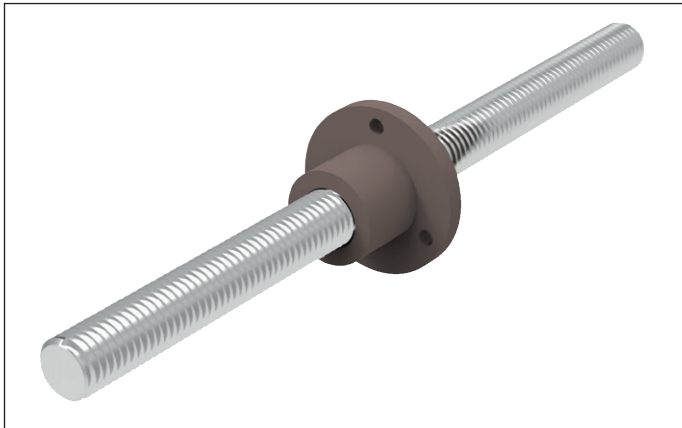

- Select the relevant size lead screw diameter and load required.



- These are precision, high helix lead screws from stainless steel (304 grade)
- We can cut length to suit and/or machine the ends to your requirements
- They have an accumulative lead error of $\pm 0.20/300\text{mm}$ (C10 grade)
- The actual clearance depends on the nut selected L1350 standard flanged nut or L1351 anti-backlash nut
- Nuts are very smooth running with little friction. They are made from plastic resin (PPS).
- The anti-backlash nuts are longer than the standard length nuts as they incorporate a spring pushing the two halves of the unit apart.

Lead screw \varnothing	Lead (distance travelled per revolution)														
	1	2	4	5	6	8	9	10	12	15	18	20	24	30	36
4	•	•													
6	•	•					•				•				
8	•	•							•				•		
10		•			•			•		•				•	
12		•	•				•			•		•			•
15				•					•			•			
20									•			•			

End machining to suit miniature bearing support units

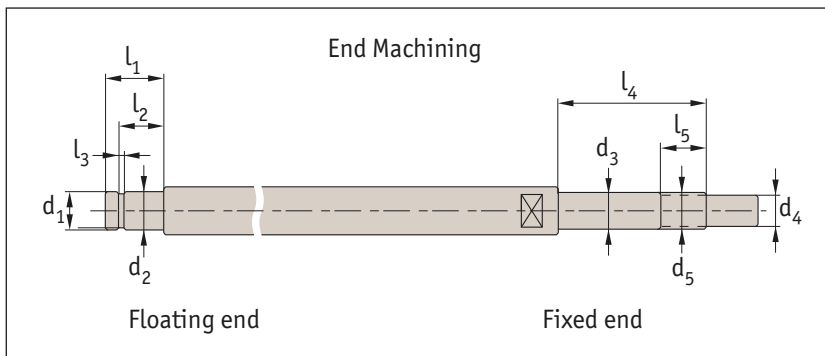

Screw \varnothing	Type	Floating	Fixed	d_1		d_2		l_1		l_2		l_3		d_3		d_4	l_4	l_5	$d_5 \times p$
4	Pillow	L1355.030	L1353.030	2		1,59		5	4	+0,05		0,5	+0,05	3		2	17,5	6,5	M3x0,5
4	Flanged	L1356.030	L1354.030																
6	Pillow	L1355.040	L1353.040	3		2,73	0	5,5	4,5	0		0,5	0	4	-0,010	3	18,5	7	M4x0,5
6	Flanged	L1356.040	L1354.040																
6	Pillow	L1355.050	L1353.050	4	-0,010	3,73	-0,06	6,5	5,5			0,5		5	-0,028	4	19,5	7	M5x0,5
6	Flanged	L1356.050	L1354.050																
8	Pillow	L1355.060	L1353.060	6		5,7		8	6,8	+0,1		0,8	+0,1	6		5	23	7	M6x0,75
8	Flanged	L1356.060	L1354.060																
10	Pillow	L1355.080	L1353.080	6		5,7		8	6,8	0		0,8	0	8	-0,013 -0,035	6.5	27	8,5	M8x1,0
10	Flanged	L1356.080	L1354.080																

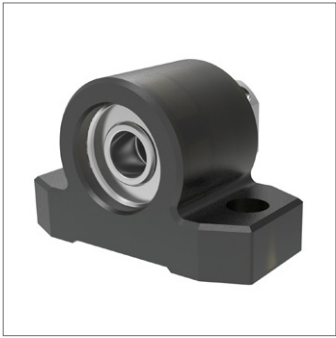

L1353

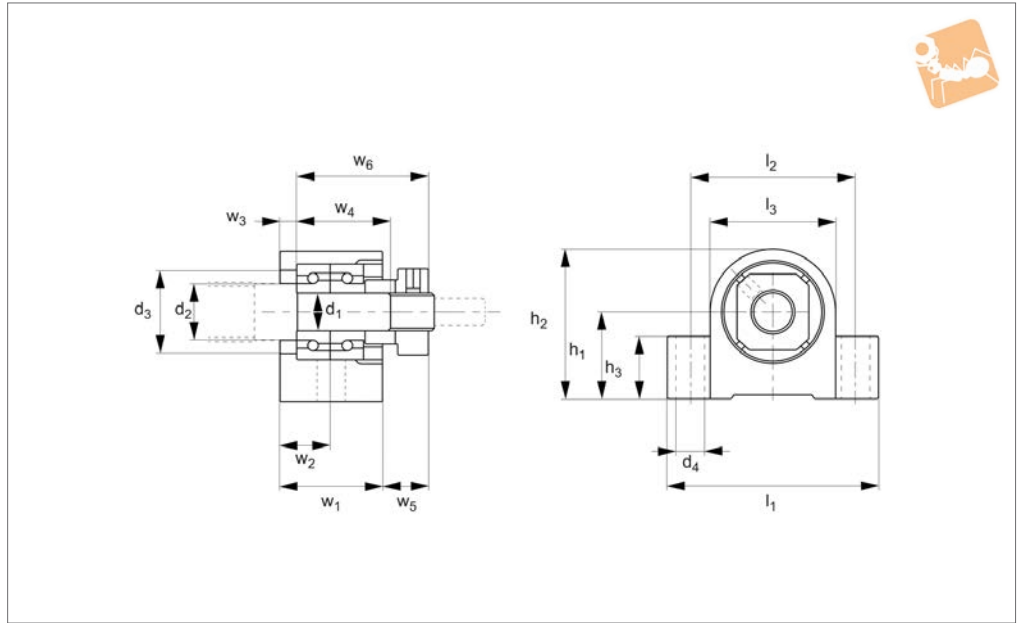

Technical Notes

Generally used with small diameter lead screws - see technical pages for lead screw core diameters and end machining

required.

Use with floating support unit (L1355). For required end machining of the lead screws see technical pages.

Tips

End machining of lead screws on request.

Order No.	d ₁	h ₁ +0 -0.03	d ₂	d ₃	d ₄	h ₂	h ₃	l ₁	l ₂	l ₃	w ₁	w ₂	w ₃	w ₄	w ₅	w ₆
L1353.030	3	9	4.3	7.3	3.5	14.5	5	24.0	18	11	12.5	6.25	1.5	11.0	5.5	16.5
L1353.040	4	10	6.0	9.5	3.5	17.0	6	27.0	21	14	14.0	7.0	2.0	11.5	5.5	17.5
L1353.050	5	11	8.0	11.5	4.5	19.5	6	30.5	23	17	15.0	7.5	2.0	12.5	5.5	18.5
L1353.060	6	13	9.5	13.3	5.5	22.5	8	35.0	26	19	17.0	8.5	2.5	16.0	7.5	22.0
L1353.080	8	17	11.5	16.5	5.6	29.0	12	41.0	32	24	20.0	10.0	3.0	18.5	9.0	26.0

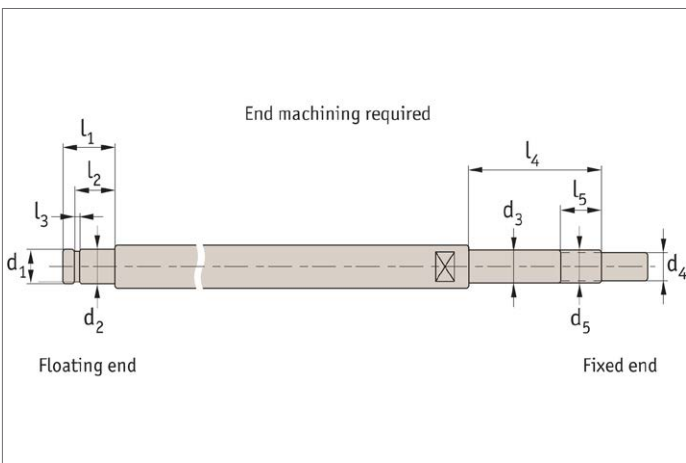



Miniature Flanged Fixed Support for miniature lead screws

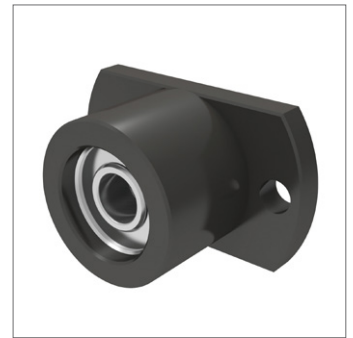
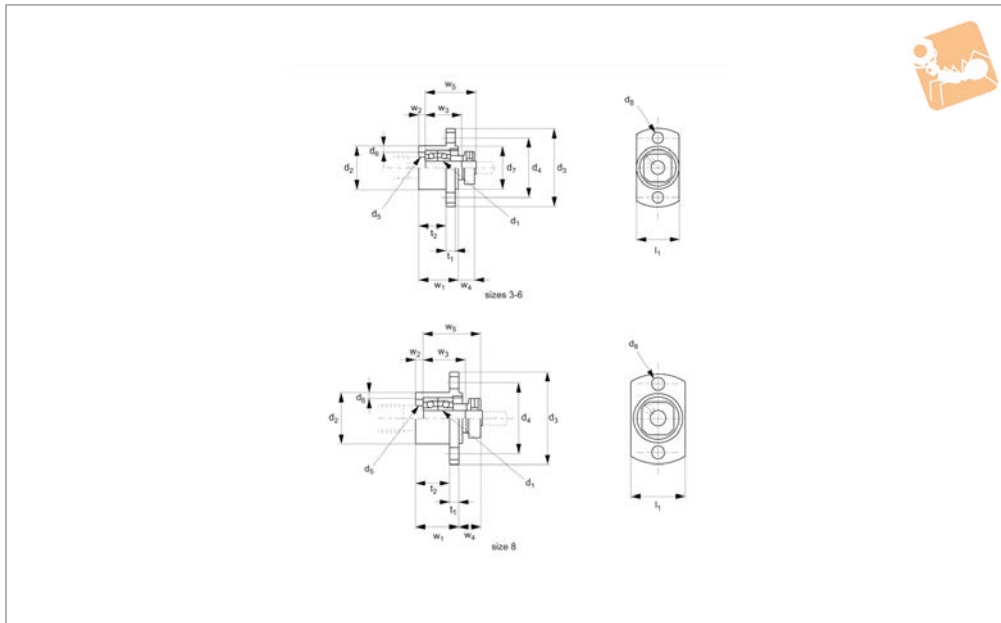

L1354

LEAD SCREWS & NUTS

Technical Notes

Generally used with small diameter lead screws - see technical pages for lead screw core diameters and end machining

required.

Use with floating support unit (L1356). For required end machining of the lead screws see technical pages.

Tips

End machining of lead screws on request.

Order No.	d ₁	d ₂ -0.007 -0.020	d ₃	d ₄	d ₅	d ₆	d ₇	d ₈	l ₁	t ₁	t ₂	w ₁	w ₂	w ₃	w ₄	w ₅
L1354.030	3	11	23	17	4.3	7.3	11.0	3.5	11	3	7.5	12.5	1.5	11.0	5.5	16.5
L1354.040	4	14	26	20	6.0	9.5	14.0	3.5	14	3	8.5	13.5	1.5	11.5	5.5	1.5
L1354.050	5	17	29	23	8.0	11.5	17.0	3.5	17	3	10.0	15.0	2.0	12.5	5.5	18.5
L1354.060	6	19	34	26	9.5	13.3	18.5	4.5	19	4	12.0	17.0	2.5	16.	7.5	22.0
L1354.080	8	24	39	31	11.5	16.5	-	4.5	24	4	16.0	20.0	3.0	18.5	9.0	26.0

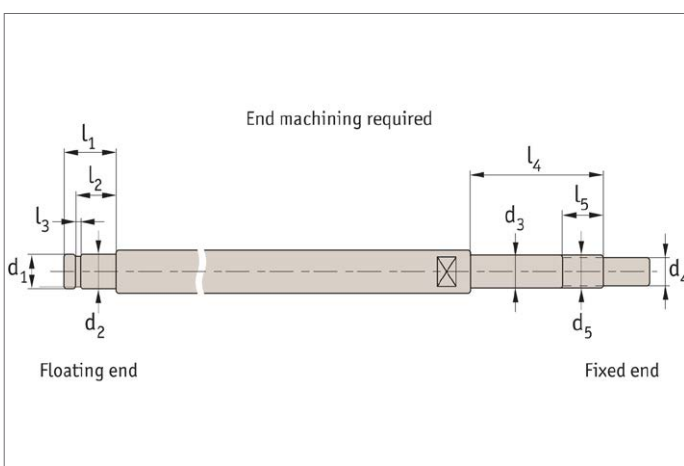

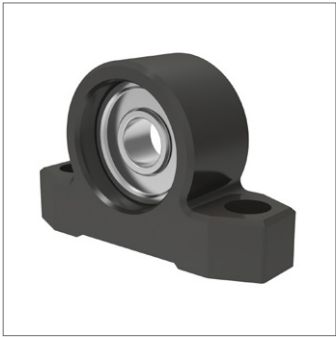

L1355

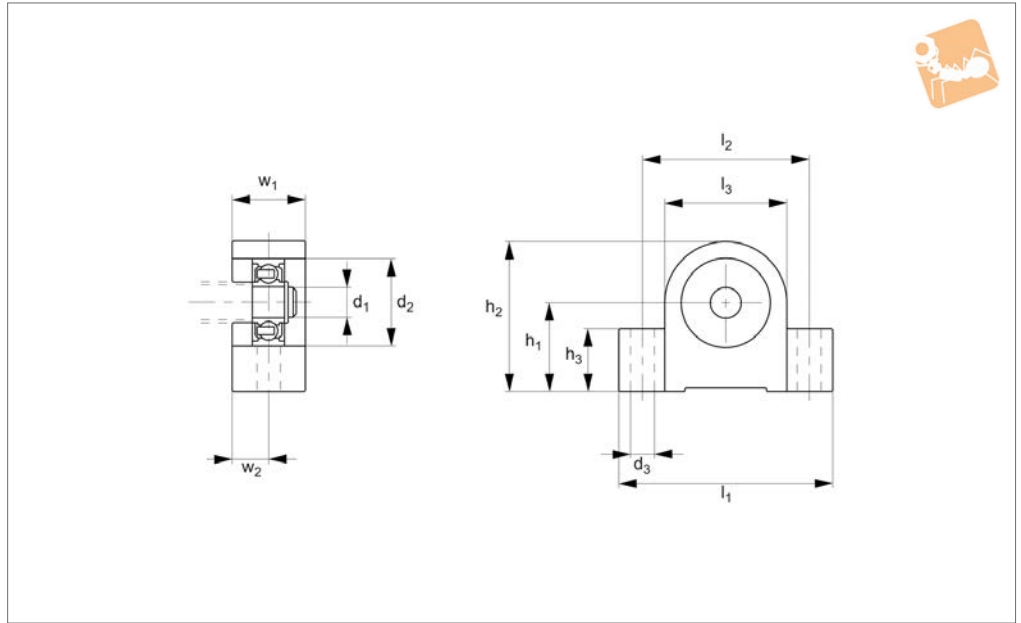

Technical Notes

Generally used with small diameter lead screws - see technical pages for lead screw core diameters and end machining

required.

Use with fixed support unit (L1353). For required end machining of the lead screws see technical pages.

Tips

End machining of lead screws on request.

Order No.	d_1	h_1 +0 -0.03	d_2	d_3	h_2	h_3	l_1	l_2	l_3	w_1	w_2
L1355.030	2	9	7	3.5	14.5	5	24.0	18	11	8	4
L1355.040	3	10	10	3.5	17.0	6	27.0	21	14	10	5
L1355.050	4	11	13	4.5	19.5	6	30.5	23	17	10	5
L1355.060	6	13	15	5.5	22.5	8	35.0	26	19	12	6
L1355.080	6	17	17	5.5	29.0	12	41.0	32	24	14	7

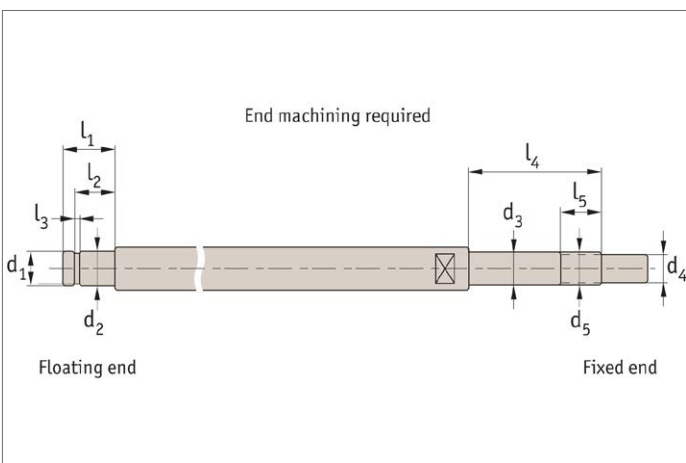



Miniature Flanged Floating Support for miniature lead screws

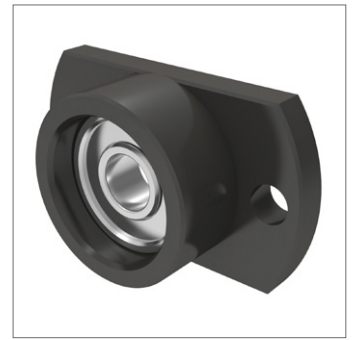
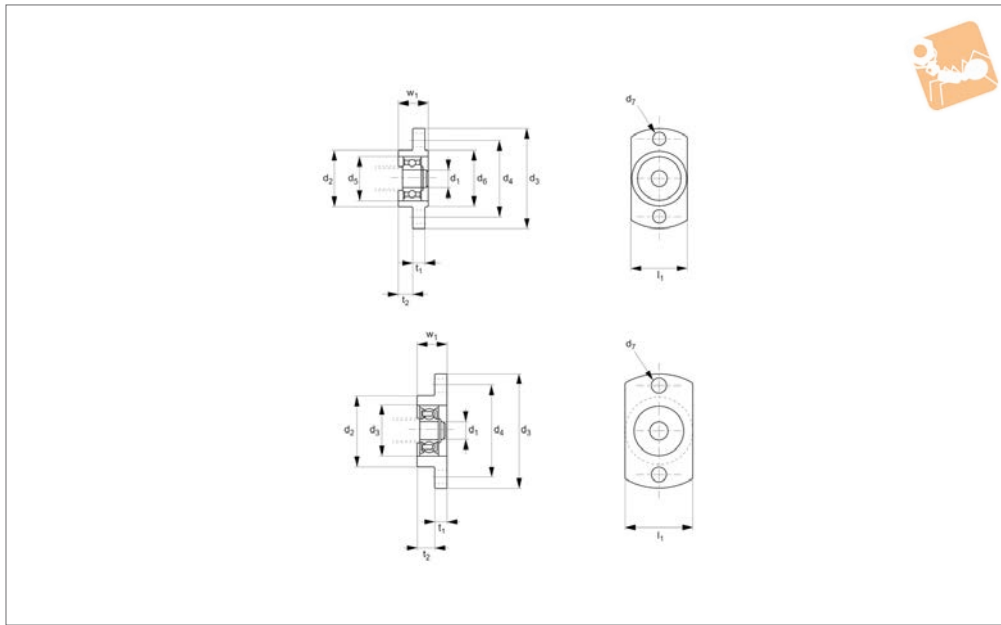

L1356

LEAD SCREWS & NUTS

Technical Notes

Generally used with small diameter lead screws - see technical pages for lead screw core diameters and end machining

required.

Use with fixed support unit (L1354). For required end machining of the lead screws see technical pages.

Tips

End machining of lead screws on request.

Order No.	d ₁	d ₂ -0.007 -0.020	d ₃	d ₄	d ₅	d ₆	d ₇	l ₁	t ₁	t ₂	w ₁
L1356.030	2	11	23	17	7	11.0	3.5	11	3	3	8
L1356.040	3	14	26	20	10	14.0	3.5	14	3	5	10
L1356.050	4	17	29	23	13	17.0	3.5	17	3	5	10
L1356.060	6	19	34	26	15	18.5	4.5	19	4	5	10
L1356.080	6	24	39	31	17	-	4.5	24	4	6	10

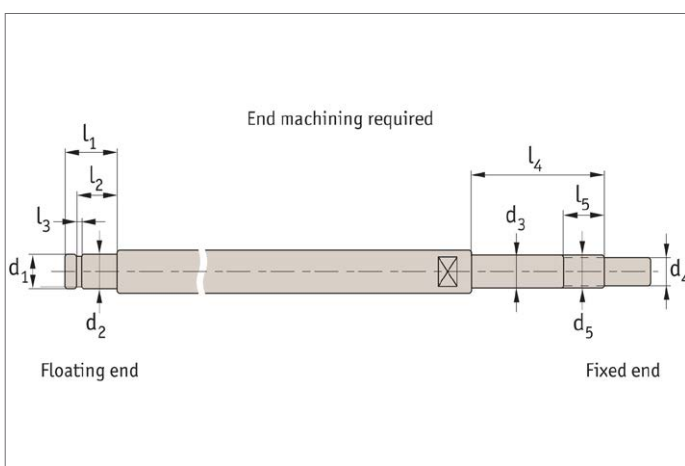



Precision lead screws

The high lead thread form maximises linear motion and minimises shaft rotation. The close tolerance, free running nuts are individually matched to their lead screws and are ideal for miniature applications requiring rotary to linear, or linear to rotary actuation.

Anti-backlash nuts

For applications requiring precision positioning there is now a newly patented Anti-backlash nut. This device, consisting of only three components, utilises the constant force of a compression spring to push two halves apart. This action eliminates any play (backlash) which exists between the internal thread of the nut and the external screw thread.

To ensure accuracy and repeatability the nut can be fine tuned through the use of many available spring constants, to meet any preload design requirements.

Lead screw specification	High precision lead screw
Lead error	±0,2mm/300mm
Repeatability	0,01mm
Straightness	0,03mm/100mm
Backlash	0,08mm (zero when using anti-backlash nut)
Temperature range	-30°C to +90°C

Design considerations

Critical speed

The critical speed of a lead screw is the maximum speed (rpm) before the screw will become dynamically unstable. This results when the forced frequency of the rotating screw corresponds to its natural frequency. Its value is dependent on the length of the screw, the diameter of the thread, and the support configuration. The critical speed value is governed by the following equation.

Critical screw speed (RPM) = $K \times C \times 10^6 \times (d/L^2)$

Where;

K = End support factor	C = Material factor
0,36 one end fixed, other free	4,5 for Stainless Steel screws
1,00 simple supports both ends	1,6 for Aluminium screws
1,47 one end fixed, one simple	d = Root diameter of the screws
2,23 both ends fixed	L = Length between bearing supports

Precision Lead Screws from Automation Components

LEAD SCREWS & NUTS

Load

In order to properly incorporate a lead screw into a design, load requirements must be taken into account. These numbers are based on the shear of the nuts and does not take shaft buckling into account. Wherever possible, nuts should be positioned so as to be put in tension, pulling the load. This eliminates the need for buckling considerations.

Listed below are some helpful formulae to assist in proper lead screw selection.

$$\text{Critical load (N)} = K \times C \times 10^6 \times (d^4/D^2)$$

Where;

K = End support factor

0,25 one end fixed, other free
(figure 1)

1,00 simple supports both ends
(figure 2)

2,00 one end fixed, one simple
(figure 3)

4,00 both ends fixed (figure 4)

C = Material factor

13,4 for Stainless Steel screws

4,8 for Aluminium screws

d = Root diameter of the screws

D = Length between bearing supports

$$\text{Torque to move a load (T)} = F \times L/2 \times \pi \times E$$

Where;

F = Load

L = Lead

E = Efficiency (see product pages)

End fixing configurations

Figure 1



Double bearing,
one end only

Figure 3



Double bearing one end,
single bearing other end

Figure 2



Single bearing both ends

Figure 4



Double bearing both ends