



<p><b>L1706</b></p>  <p>Closed, open + adjustable</p>	<p><b>L1712</b></p>  <p>Double compliment versions</p>	<p><b>L1715</b></p>  <p>Compact versions</p>
<p><b>L1718</b></p>  <p>Front flanged standard</p>	<p><b>L1723</b></p>  <p>Front flanged double compliment</p>	<p><b>L1731</b></p>  <p>Centre flanged double compliment</p>
<p><b>L1740</b></p>  <p>Superball bushings</p>	<p><b>L1750</b></p>  <p>Closed linear carriage</p>	<p><b>L1753</b></p>  <p>Open linear carriage</p>

**For full technical information,  
see end of product section.**

**Linear Ball Bushings from Automation Components**

LINEAR BEARINGS



## L1706

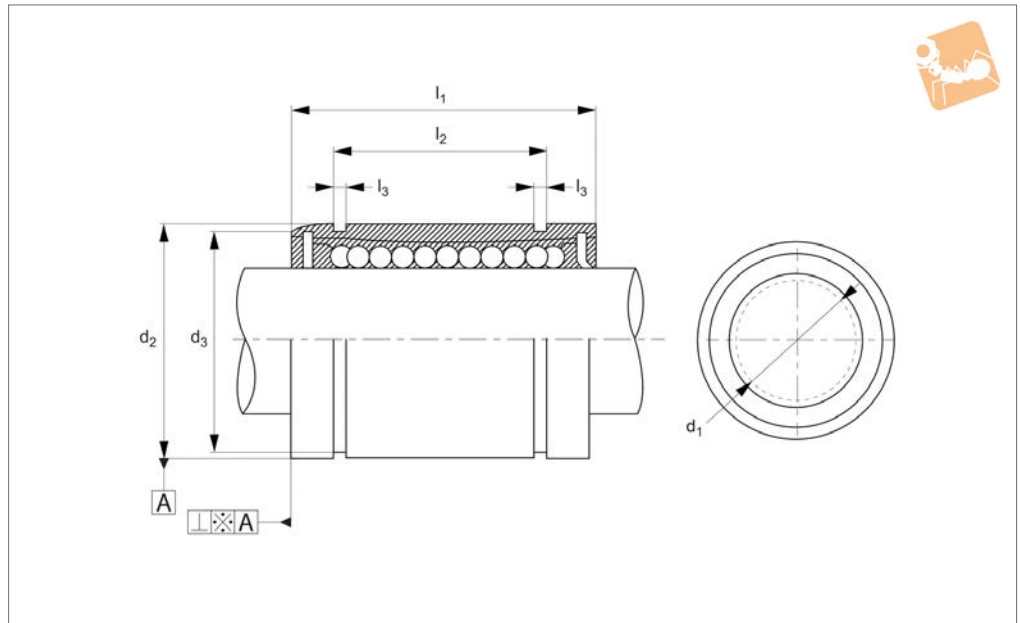

### Material

Hardened and ground body from bearing steel. Single body resin retainer (POM). Supplied with nitrile rubber (NBR) end-seals -UU as standard.

### Technical Notes

For use with hardened shafts only (see part nos. L1770 - L1772) - tolerance h6.

Perpendicularity .A is better than 15 $\mu$ .

For part numbers with <sup>-1</sup> shaft tolerance required is g6. Temperature range: -20°C to +80°C.

Steel ball retainers can be supplied for higher temperature applications up to 120°C - with no end seals. Please advise at time of ordering if this is required.

### Tips

Superball linear bearings are also available (3 x load rating of standard bushings and 27 x travel life see part nos. L1740 and L1742.)

Nickel plated version with stainless steel balls (for corrosion resistance) on request - or stainless steel version no. L1709.

Order No.	d <sub>1</sub> tol. h6	d <sub>2</sub> tol. h6	l <sub>1</sub> +0 -0.3	d <sub>3</sub>	l <sub>2</sub> +0 -0.3	l <sub>3</sub>	No. of ball circuits	Dyn. load C N max.	Static load C <sub>0</sub> N max.	Weight g
L1706.005	5	12	22	11.5	14.5	1.10	4	200	260	12
L1706.006-1	6	12	19	11.5	13.5	1.10	4	200	260	8
L1706.008	8	16	25	15.2	16.5	1.10	4	260	400	20
L1706.010-1	10	19	29	18.0	22.0	1.30	4	370	540	30
L1706.012	12	22	32	21.0	22.9	1.30	4	410	590	41
L1706.016	16	26	36	24.9	24.9	1.30	5	770	1170	57
L1706.020	20	32	45	30.3	31.5	1.60	5	860	1370	91
L1706.025	25	40	58	37.5	44.1	1.85	6	980	1560	215
L1706.030	30	47	68	44.5	52.1	1.85	6	1560	2740	325
L1706.040	40	62	80	59.0	60.6	2.15	6	2150	4010	705
L1706.050	50	75	100	72.0	77.6	2.65	6	3820	7930	1130
L1706.060	60	90	125	86.5	101.7	3.15	6	4700	9990	2220

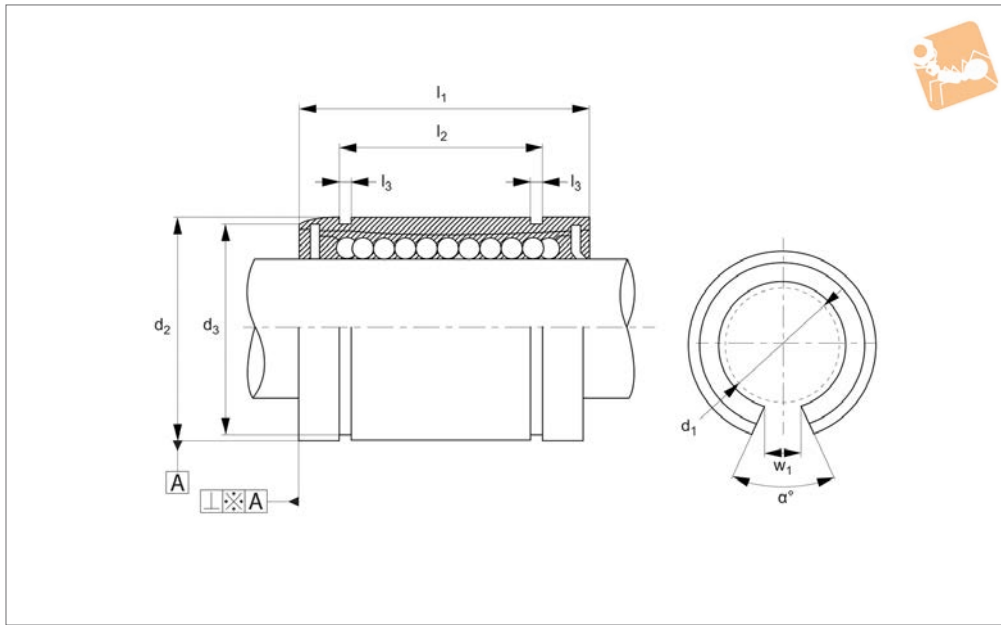

## L1707

LINEAR BEARINGS

### Material

Hardened and ground body from bearing steel. Single body resin retainer (POM). Supplied with nitrile rubber (NBR) end-seals -UU as standard.

### Technical Notes

For use with hardened shafts only (see part

nos. L1770 - L1772) - tolerance h6. Perpendicularity . A is better than 15μ. Temperature range: -20°C to +80°C. Steel ball retainers can be supplied for higher temperature applications up to +120°C - with no end seals. Please advise at time of ordering if this is required.

### Tips

$d_2$  is the dimension before the bush has been slotted. Superball linear bearings are also available (3 x load rating of standard bushings and 27 x travel life see part nos. L1740 and L1742.)

Order No.	$d_1$ tol. h6	$d_2$ tol. h6	$l_1$ +0 -0.3	$d_3$	$l_2$ +0 -0.3	$l_3$	$w_1$	$\alpha$ °	No. of ball circuits	Dyn. load C N max.	Static load $C_0$ N max.	Weight g
L1707.012	12	22	32	21.0	22.9	1.30	7.3	78°	3	410	590	41
L1707.016	16	26	36	24.9	24.9	1.30	10.0	78°	4	770	1170	57
L1707.020	20	32	45	30.3	31.5	1.60	10.0	60°	5	860	1370	91
L1707.025	25	40	58	37.5	44.1	1.85	12.5	60°	6	980	1560	215
L1707.030	30	47	68	44.5	52.1	1.85	12.5	50°	6	1560	2740	325
L1707.040	40	62	80	59.0	60.6	2.15	16.8	50°	6	2150	4010	705
L1707.050	50	75	100	72.0	77.6	2.65	21.0	50°	6	3820	7930	1130
L1707.060	60	90	125	86.5	101.7	3.15	27.2	54°	6	4700	9990	2220



**L1708**

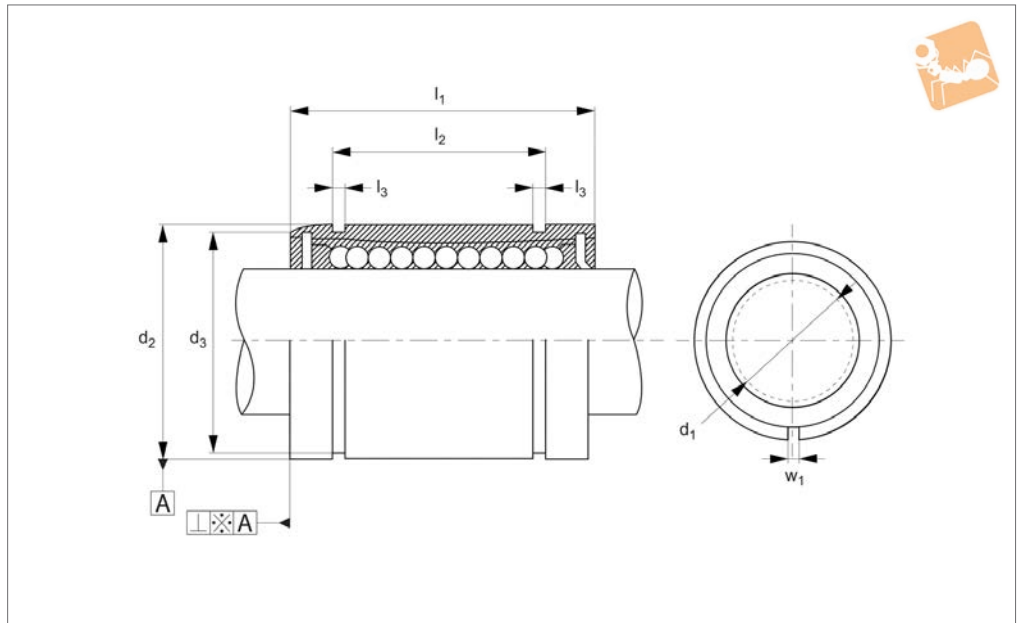

**Material**

Hardened and ground body from bearing steel. Single body resin retainer (POM). Supplied with nitrile rubber (NBR) end-seals -UU as standard.

**Technical Notes**

For use with hardened shafts only (see part nos. L1770 - L1772) - tolerance h6. Perpendicularity TA is better than 15µ.

For part numbers with <sup>-1</sup> shaft tolerance required is g6. Temperature range: -20°C to +80°C.

Steel ball retainers can be supplied for higher temperatures applications up to 120°C - with no end seals. Please advise at time of ordering if this is required.

**Tips**

d<sub>2</sub> is the dimension before the bush has

been slotted. Superball linear bearings are also available (3 x load rating of standard bushings and 27 x travel life see part nos. L1740 and L1742.)

Nickel plated version with stainless steel balls (for corrosion resistance) on request - or stainless steel version no. L1711.

Order No.	d <sub>1</sub> tol. h6	d <sub>2</sub> tol. h6	l <sub>1</sub>	d <sub>3</sub>	l <sub>2</sub>	l <sub>3</sub>	w <sub>1</sub>	No. of ball circuits	Dyn. load C N max.	Static load C <sub>0</sub> N max.	Weight g
L1708.005	5	12	22	11.5	14.5	1.10	1.0	4	200	260	12
L1708.006-1	6	12	19	11.5	13.5	1.10	1.0	4	200	260	8
L1708.008	8	16	25	15.2	16.5	1.10	1.0	4	260	400	20
L1708.010-1	10	19	29	18.0	22.0	1.30	1.0	4	370	540	30
L1708.012	12	22	32	21.0	22.9	1.30	1.5	4	410	590	41
L1708.016	16	26	36	24.9	24.9	1.30	1.5	5	770	1170	57
L1708.020	20	32	45	30.3	31.5	1.60	2.0	5	860	1370	91
L1708.025	25	40	58	37.5	44.1	1.85	2.0	6	980	1560	215
L1708.030	30	47	68	44.5	52.1	1.85	2.0	6	1560	2740	325
L1708.040	40	62	80	59.0	60.6	2.15	3.0	6	2150	4010	705
L1708.050	50	75	100	72.0	77.6	2.65	3.0	6	3820	7930	1130
L1708.060	60	90	125	86.0	101.7	3.15	3.0	6	4700	9990	2220



# Long Linear Ball Bushings

double length

## Linear Bearings

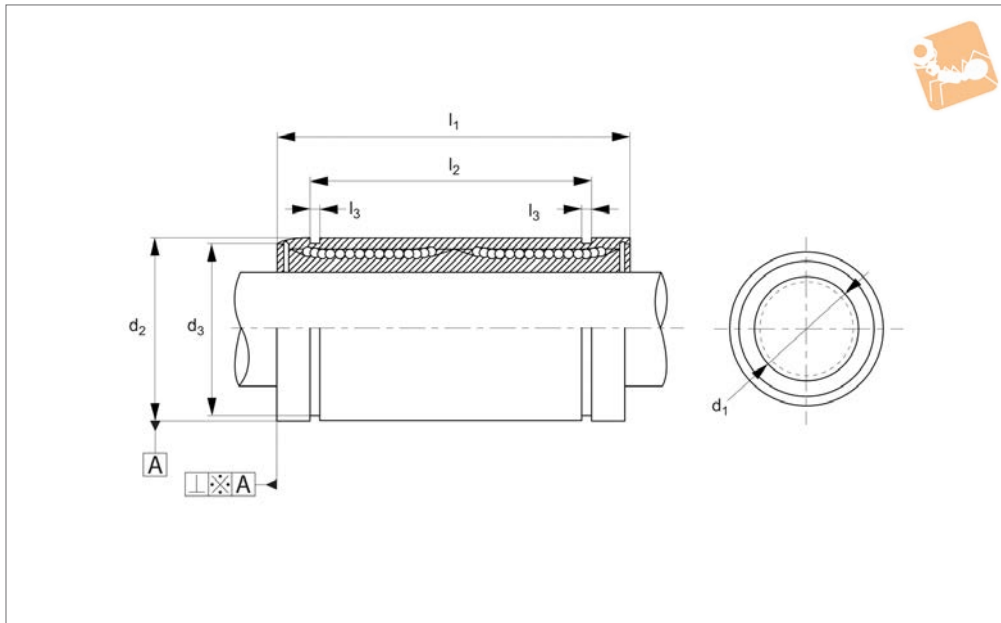

**L1712**

LINEAR BEARINGS

### Material

Hardened and ground body from bearing steel.

Single body resin retainer (POM).

Supplied with nitrile rubber (NBR) end-seals -UU as standard.

### Technical Notes

For use with hardened shafts only (see part

nos. L1770 - L1772) - tolerance h6.

Perpendicularity A is better than 15 $\mu$ .

Temperature range: -20°C to +80°C.

Steel ball retainers can be supplied for higher temperature applications up to +120°C - with no end seals. Please advise at time of ordering if this is required.

### Tips

Nickel plated version with stainless steel balls (for corrosion resistance) on request - or stainless steel version no. L1713.

Order No.	d <sub>1</sub> tol. h6	d <sub>2</sub> tol. h6	l <sub>1</sub>	d <sub>3</sub>	l <sub>2</sub>	l <sub>3</sub>	No. of ball circuits	Dyn. load C N max.	Static load C <sub>0</sub> N max.	Weight g
L1712.008	8	16	45	15.2	33.0	1.10	4	430	780	31
L1712.012	12	22	57	21.0	45.8	1.30	4	650	1200	80
L1712.012-1	12	22	61	21.0	45.8	1.30	4	830	1600	80
L1712.016	16	26	70	24.9	49.8	1.30	5	1230	2350	145
L1712.020	20	32	80	30.3	61.0	1.60	5	1400	2750	180
L1712.025	25	40	112	38.0	82.0	1.85	6	1560	3140	440
L1712.030	30	47	123	44.5	104.2	1.85	6	2490	5490	580
L1712.040	40	62	154	59.0	121.2	2.15	6	3430	8040	1170
L1712.050	50	75	192	72.0	155.2	2.65	6	6080	15900	3100
L1712.060	60	90	211	86.5	170.0	3.15	6	7650	20000	3500

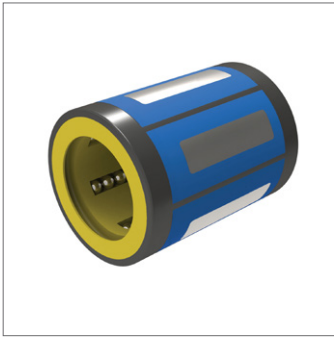

**L1715**

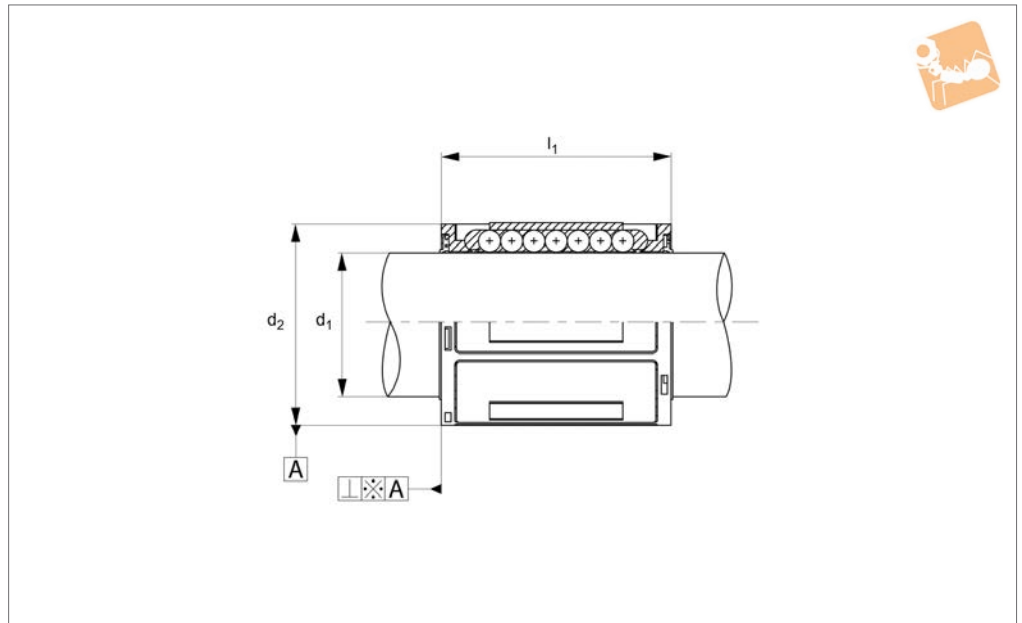

**Material**

Durable plastic body with corrosion resistant hardened steel raceway segments.

**Technical Notes**

Advantages - Low cost, compact construc-

tion, press fit, oil resistant seal, corrosion resistant housing.

For use with hardened shafts only (see part nos. L1770 - L1772) - tolerance h6.

Perpendicularity A is better than 15µ.

Temperature range: -20°C to +80°C.

**Tips**

Easy assembly by press fitting, no additional retention is required when fitted into a bore with a tolerance of J6 or J7.

Order No.	d <sub>1</sub> tol. h6	d <sub>2</sub> tol. h6	l <sub>1</sub> ±0.2	No. of ball circuits	Dyn. load C N max.	Static load C <sub>0</sub> N max.	Weight g
L1715.008	8	15	24	4	350	260	6.9
L1715.010	10	17	26	4	416	320	8.4
L1715.012	12	19	28	4	480	385	11.3
L1715.014	14	21	28	5	640	440	13.3
L1715.016	16	24	30	5	925	625	18.3
L1715.020	20	28	30	6	1165	790	22.1
L1715.025	25	35	40	6	2100	1370	51.2
L1715.030	30	40	50	6	2870	2100	70.6
L1715.040	40	52	60	7	5200	4100	90.2
L1715.050	50	62	70	8	6620	5600	110.2

### Linear ball bushings

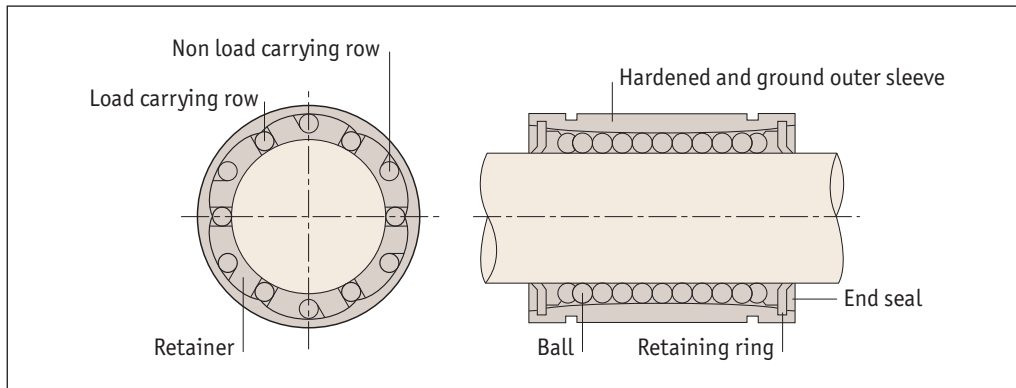

#### Applications

- Computers and peripheral equipment.
- Recording equipment.
- Linear motion systems.
- Multi-axis drilling machine.
- Printing machines.
- Food packaging machines.
- Punching presses.
- Tool grinders.
- Assembly systems.
- Card selectors.

#### Interchangeability

Our linear bushing systems are designed to have full interchangeability, with other manufacturers' parts. **For shafting see part numbers L1770 to L1785.**

#### High precision retainer

The single body retainer guides 4-6 ball circuits. It precisely guides the balls with a smooth motion.

#### Tolerance of housing bore

Normal fit is standard, pressed fit is for without clearance.

Type	Case	
	Normal fit	Pressed fit
Part no.		
L1706 to L1733	H7	K6, J6
L1706... <sup>-1</sup> to L1733... <sup>-1</sup>	H7	J7

#### Rigid outer sleeve

The hardened and precisely ground outer sleeve is made of bearing steel.

#### L1750 bushing carriages

Consists of light aluminium case and L1706 type linear bushing, so the installation can be finished simply by bolting. Longer life can be obtained by adjusting the orientation of the ball circuits in the linear carriage element against the direction of load.

#### Tolerance of shaft

Type	Shaft	
	Normal fit	Tight fit
Part no.		
L1706 to L1733	h6	k6
L1706... <sup>-1</sup> to L1733... <sup>-1</sup>	f6, g6	h6



#### Basic dynamic load rating C

The basic dynamic load rating is defined as the constant load both in direction and magnitude under which a group of identical linear bushings are individually operated. 90% of the units can travel 50Km without failing due to rolling contact fatigue.

#### Basic static load rating C<sub>0</sub>

If a linear bushing is subject to an excessive load or impact, a permanent deformation occurs between the raceway and the rolling element. The basic static load rating is defined as the static load that gives a prescribed constant contact stress at the centre of the contact area between the rolling element and raceway receiving the maximum load.

#### Relationships between load ratings and the position of ball circuits

Load ratings of linear bushing are affected by the position of the ball circuits as shown below.

Load ratings and orientation of balls.

No of ball rows	Orientation of balls	
	Maximum load rating	Minimum load rating
4		
	$F = 1.41 \times C$	$F = C$
5		
	$F = 1.46 \times C$	$F = C$
6		
	$F = 1.26 \times C$	$F = C$





# Technical Information

## Load rating important information



When designing a linear motion system it is necessary to consider how the application will affect performance. The following examples demonstrate how the position of the load and the centre of gravity can influence product selection. When evaluating your application, review each of the forces acting on your system and determine the product that best suits your needs.

$$F_{1z} = \frac{W}{4} + \left( \frac{W}{2} \cdot \frac{d_2}{d_0} \right) - \left( \frac{W}{2} \cdot \frac{d_3}{d_1} \right)$$

$$F_{2z} = \frac{W}{4} - \left( \frac{W}{2} \cdot \frac{d_2}{d_0} \right) - \left( \frac{W}{2} \cdot \frac{d_3}{d_1} \right)$$

$$F_{3z} = \frac{W}{4} - \left( \frac{W}{2} \cdot \frac{d_2}{d_0} \right) + \left( \frac{W}{2} \cdot \frac{d_3}{d_1} \right)$$

$$F_{4z} = \frac{W}{4} + \left( \frac{W}{2} \cdot \frac{d_2}{d_0} \right) + \left( \frac{W}{2} \cdot \frac{d_3}{d_1} \right)$$

### Horizontal application

For uniform speed or when stopped.

$$F_{1z} = \frac{W}{4} + \left( \frac{W}{2} \cdot \frac{d_2}{d_0} \right) - \left( \frac{W}{2} \cdot \frac{d_3}{d_1} \right)$$

$$F_{2z} = \frac{W}{4} - \left( \frac{W}{2} \cdot \frac{d_2}{d_0} \right) - \left( \frac{W}{2} \cdot \frac{d_3}{d_1} \right)$$

$$F_{3z} = \frac{W}{4} - \left( \frac{W}{2} \cdot \frac{d_2}{d_0} \right) + \left( \frac{W}{2} \cdot \frac{d_3}{d_1} \right)$$

$$F_{4z} = \frac{W}{4} + \left( \frac{W}{2} \cdot \frac{d_2}{d_0} \right) + \left( \frac{W}{2} \cdot \frac{d_3}{d_1} \right)$$

### Horizontal application

For uniform speed or when stopped.



#### Side mounted application

For uniform speed or when stopped.

$$F_{1Y} \sim F_{4Y} = \left( \frac{W}{2} \cdot \frac{d_3}{d_0} \right)$$

$$F_{1Z} = F_{4Z} = \frac{W}{4} + \left( \frac{W}{2} \cdot \frac{d_2}{d_0} \right)$$

$$F_{2Z} = F_{3Z} = \frac{W}{4} + \left( \frac{W}{2} \cdot \frac{d_2}{d_0} \right)$$

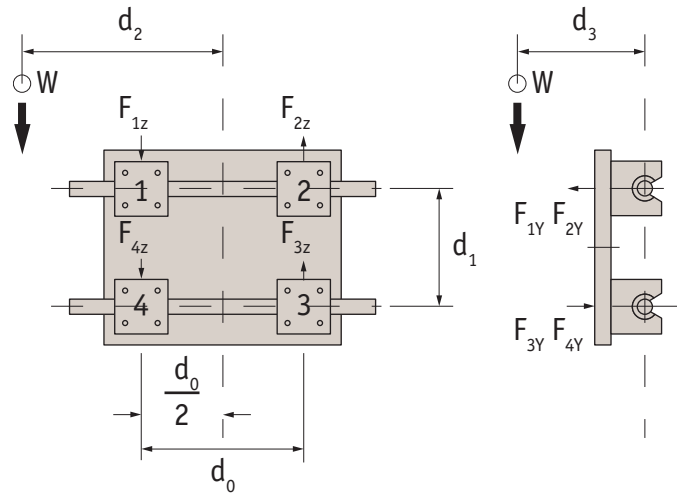

#### Vertical application

For uniform speed or when stopped. On start up/stop the load varies due to inertia in the system.

$$F_{1X} \sim F_{4X} = \left( \frac{W}{2} \cdot \frac{d_2}{d_0} \right)$$

$$F_{1Y} \sim F_{4Y} = \left( \frac{W}{2} \cdot \frac{d_3}{d_0} \right)$$

$$F_{1X} + F_{4X} \sim F_{2X} + F_{3X}$$

$$F_{1Y} + F_{4Y} \sim F_{2Y} + F_{3Y}$$

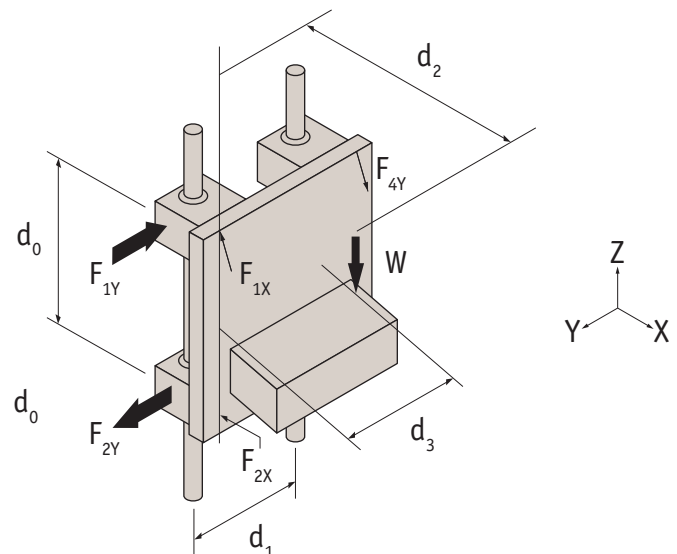

### Friction

The coefficient of friction ( $\mu$ ) of Automotion Components ball bushings without seals is very low at approximately 0.001 to 0.003. When seals are used to retain lubricant or to prevent entry of foreign particles, friction resistance must be taken into account for determining total frictional drag. This protection measure adds to the frictional drag of the bearing system. There is a fine line between minimizing frictional drag and maximizing containment protection which is controlled by the addition or removal of seals, wipers or scrapers.

Linear bushings are used with grease or oil lubrication but in some cases can be used without any lubrication.

### Grease lubrication

Before applying the grease, the anti-corrosive oil must be removed with kerosene or an organic solvent. The grease must be applied when the bushing is dry. Grease must be applied directly on the balls for linear bushing with seals. Lithium soap of viscosity mark (JIS No.2) is recommended for use.

### Oil lubrication

There is no need to to remove the anti-corrosive oil when oil is used for lubrication. ISO viscosity grade VG15~100 oil is usually used according to the temperature ranges below. Drop the oil onto the shaft for lubrication, or supply it through an oil hole provided on the housing (see illustration below). However, dropping lubrication cannot be used on linear bushings with seals as the seals remove the oil.

Operating temperature	Viscosity
-30°C to +50°C	VG 15 to 46
+50°C to +80°C	VG 46 to 100

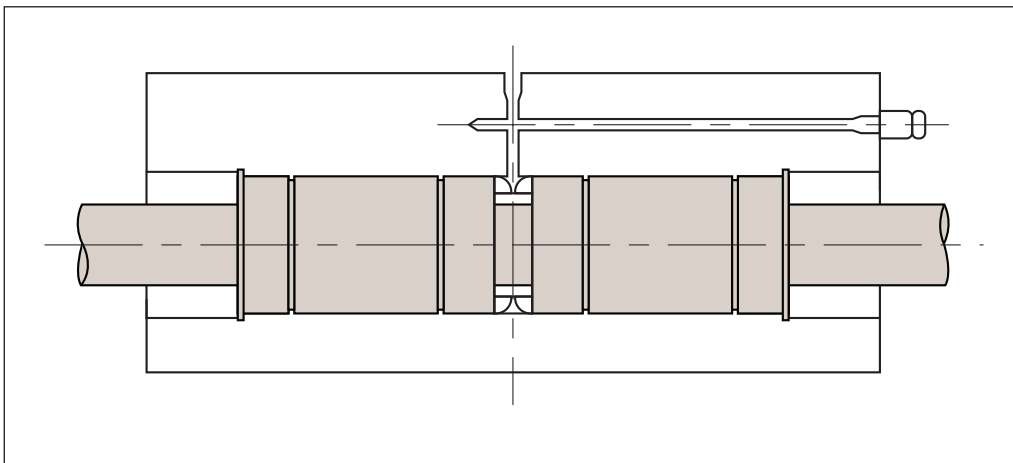



Standard type

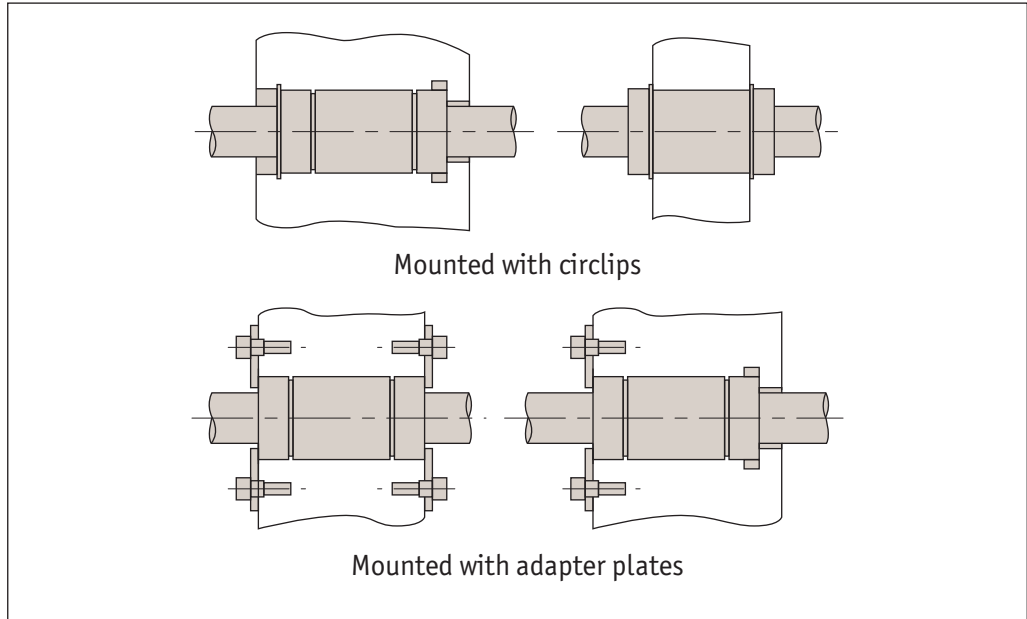

For shaft Ø	Circlip	
	External (for Shaft)	Internal (for Bore)
5	P0380.012-A2	P0381.012-A2
6	P0380.012-A2	P0381.012-A2
8	P0380.016-A2	P0381.016-A2
10	P0380.019-A2	P0381.019-A2
12	P0380.022-A2	P0381.022-A2
16	P0380.026-A2	P0381.026-A2
20	P0380.032-A2	P0381.032-A2
25	P0380.040-A2	P0381.040-A2
30	P0380.048-A2	P0381.047-A2
40	P0380.065-A2	P0381.062-A2
50	P0380.075-A2	P0381.075-A2
60	P0380.090-A2	P0381.090-A2

Flanged type

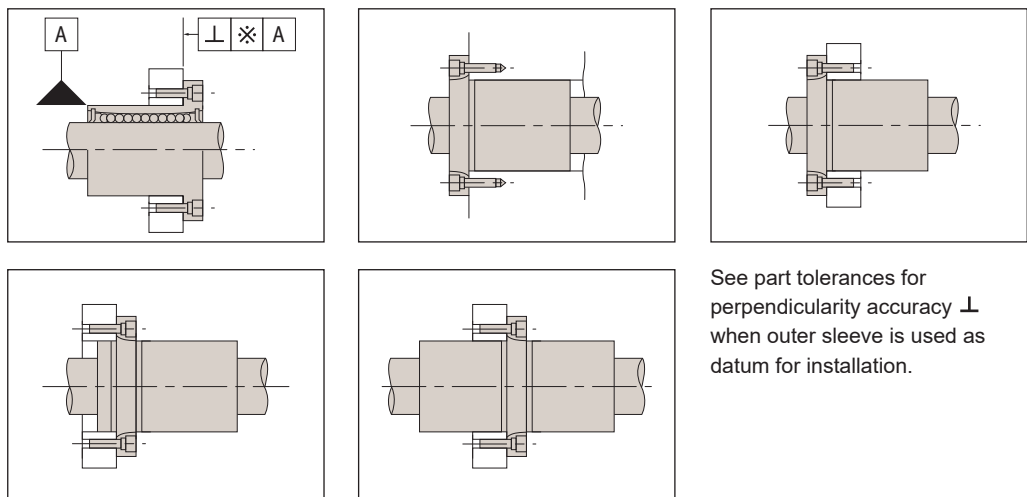

Linear Ball Bushings from Automation Components

LINEAR BEARINGS

### Adjustable type bearings

Adjustment of clearance (for adjustable type bearings and shafts), is achieved with an adjustable housing assembly (as shown below). In this case, the slotted side of linear bushing should be located at 90° to the open side of housing for equal radial deformation.

#### Mounting of adjustable type bearing

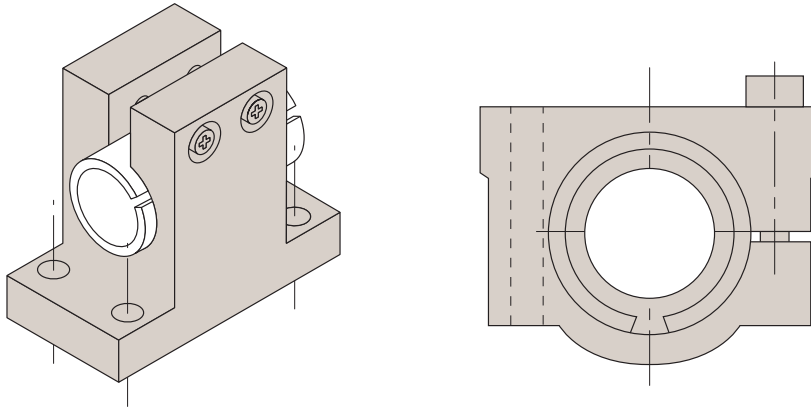

#### When moment load applies

External loads should be distributed uniformly on a linear bushing. When moment loads are applied, two or more linear bushings should be used on one shaft, and the distance between the two linear bushings should have adequate spacing. Calculate the equivalent load when the moment loads are applied and choose the correct linear bushing.

### Open type bearings

Open type bearings can be used with a clearance adjustable housing as shown below. Light preload is applied for normal use, heavy preload should be avoided.

#### Mounting of open type bearing

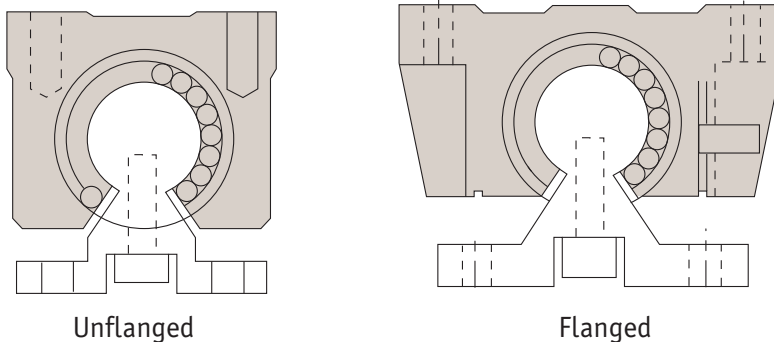

### L1750 Bushing carriages

L1750 carriages can be mounted from both the top or the bottom, minimising assembly time.

#### Mounting of case unit

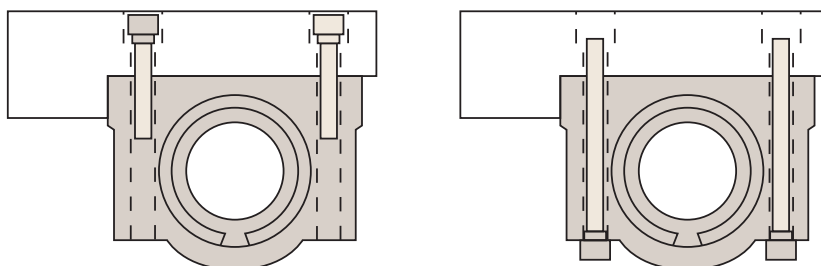

#### Fixing holes

Carriage fixing holes are threaded from the top a certain distance down. Fixing holes from the bottom are through holes so the screw size when mounting from below needs to be smaller than the thread size if you were mounting from the top.



**Application tips**

For mounting a standard type linear bushing into a housing, a jig should be used to avoid directly striking the outer sleeve or seal during installation.

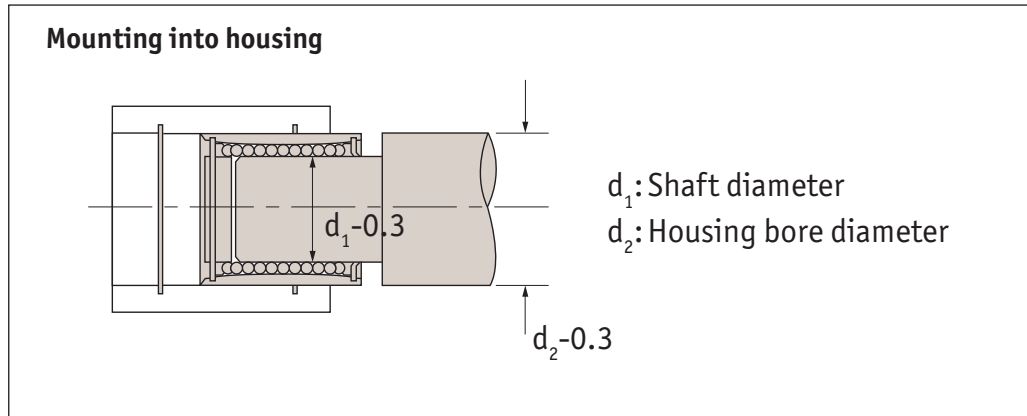

**Insertion of shaft**

Care must be taken when inserting a shaft into a linear bushing. If the shaft is inserted incorrectly, the ball retaining cage may be damaged and the balls loosened from position.

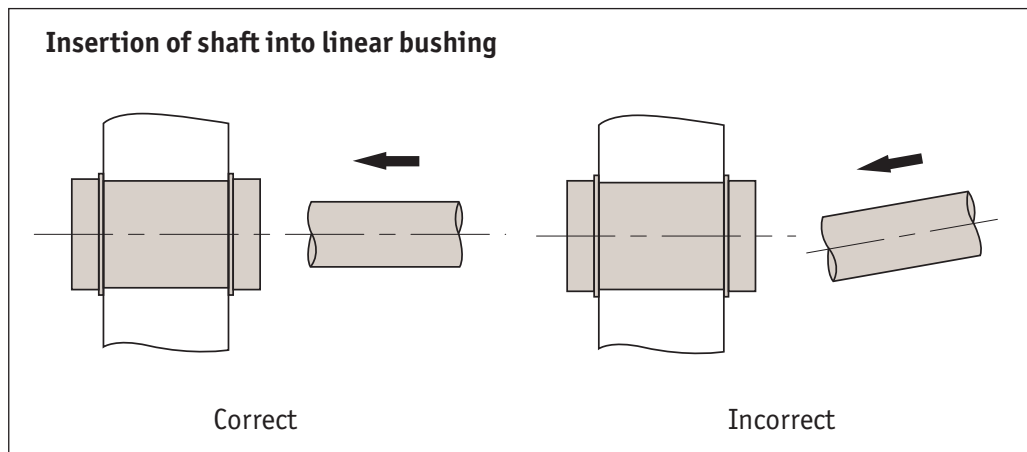

**Rotational motion prohibited**

Linear bushing are not suitable for rotational motion. If the linear bushing is exposed to rotational motion it may lead to unexpected accidents.

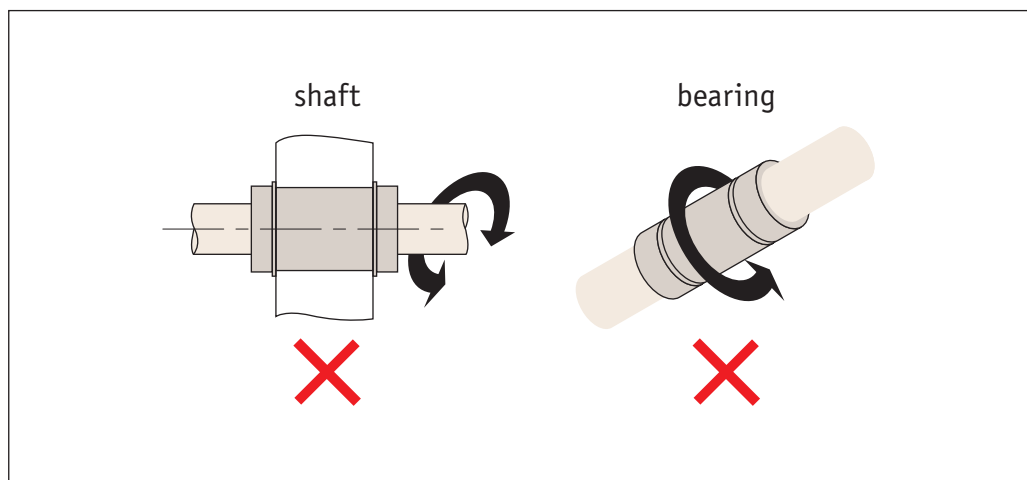

### Static safety factor $f_s$

A linear motion system may receive an unpredictable external force due to vibration or impact while it is at rest or in motion, or inertia as a result of starting and stopping. It is, therefore, necessary to consider the static safety factor against operating loads. The static safety factor ( $f_s$ ) indicates the ratio of a linear motion system load carrying capacity (basic static load rating,  $C_0$ ) to the load exerted thereon.

$$f_s = \frac{C_0}{P} \quad \text{or} \quad f_s = \frac{M_0}{M}$$

- $f_s$  = Static safety factor
- $C_0$  = Basic static load rating (N)
- $M_0$  = Static permissible moment (Nmm)
- $P$  = Calculated load (N)
- $M$  = Calculated moment (Nmm)

To calculate a load exerted on the linear motion system, the mean load for calculating the service life and the maximum load for calculating the static safety factor must be obtained in advance. A system can receive unexpected excessive load when it is subject to frequent starts and stops, placed under machining loads, or when a severe moment is applied by overhanging loads. When selecting the correct type of a linear motion system for your application, be sure that the type you are considering can bear the maximum possible load when stopped and in operation. Both tables below specify the standard values for the static safety factors.

Machine used	Loading conditions	$f_s$ Lower limit
Ordinary industrial machine	No vibration or impact	1,0 ~ 1,3
	Vibration and/or impact	2,0 ~ 3,0
Machine tool	No vibration or impact	1,0 ~ 1,5
	Vibration and/or impact	2,5 ~ 7,0

### For large radial loads

$$\frac{f_h \cdot f_t \cdot f_c \cdot C_0}{P} \geq f_s$$

- $C_0$  = Basic static load rating (N)
- $f_h$  = Hardness factor
- $f_c$  = Contact factor
- $P$  = Calculated load (N)
- $f_t$  = Temperature factor



**Hardness factor  $f_h$**

To achieve the optimum load rating of the linear ball bushings, the shaft hardness must be 58 to 64 HRC. At a hardness below this range, the basic dynamic and static load ratings decrease. The ratings must therefore be multiplied by the respective hardness factors ( $f_h$ ).

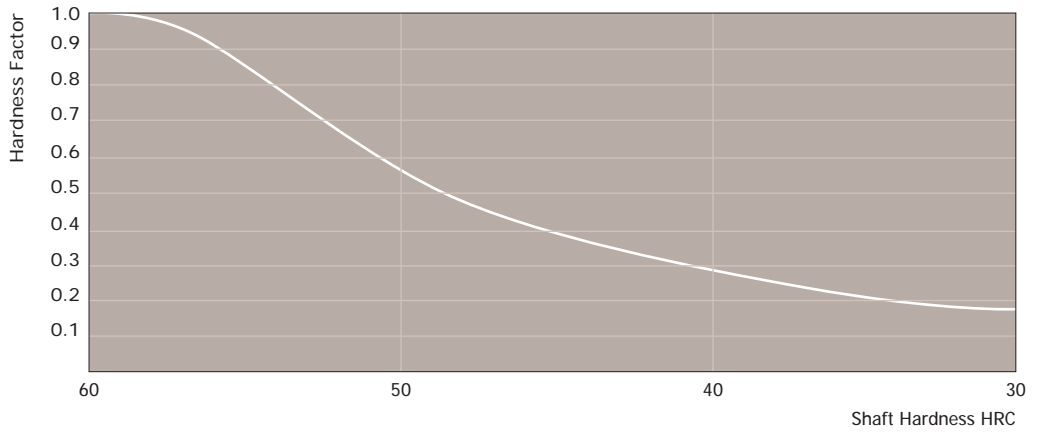

**Temperature factor  $f_t$**

For linear bushings used at ambient temperatures of over 100 °C, a temperature factor must be taken into consideration. For higher than 80 °C applications, the seals, end plates, and retainer must be changed for high temperature specifications. (Temperature range: -20 °C - +80 °C). Please note that the selected linear bushing in this case must be a model with high temperature specifications.

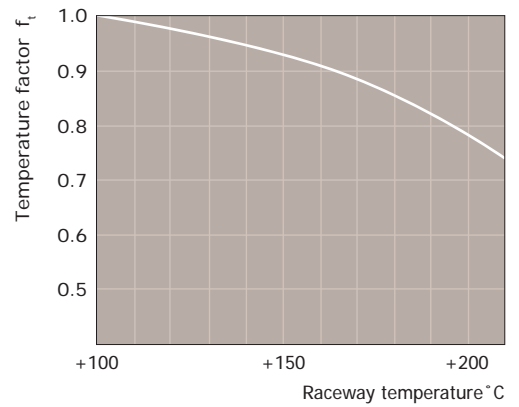

**Contact factor  $f_c$**

When multiple linear bushings are used moments and mounting surface precision will affect operation, making it difficult to achieve uniform load distribution. In this case, multiply the basic load rating (C or  $C_0$ ) by a contact factor selected from the table.

Number of linear bushing on a shaft	Contact factor $f_c$
2	0.81
3	0.72
4	0.66
5	0.61
Over 6	0.60
In normal use	1.00

**Operating conditions  $f_w$**

Some machines may cause vibration. It is particularly difficult to determine the magnitude of vibration that develops during high-speed operation, as well as that of impact during repeated starting and stopping and stopping in normal use. Therefore, where the effects of speed and vibration are estimated to be significant, divide the basic dynamic load rating (C) by a load factor selected from the table.

Operating conditions		Load factor $f_w$
Load conditions	Speed	
No impact and vibration	Under 15m/min	1.0~1.5
Slight impact and vibration	Under 60m/min	1.5~2.0
Considerable impact and vibration	Over 60m/min	2.0~4.0



Linear bushings load ratings and travel life are influenced by load direction, ball circuit orientation, and hardness of the shaft.

### Basic dynamic load rating (C) and travel life

The travel life of a linear bushing is determined largely by the quality of the shaft. The basic dynamic load rating is the maximum continuous load that can be applied to the linear bushing with 90% of reliability and achieving over 50km of operation under normal conditions. When calculating the nominal life for 100km, please divide the dynamic load rating C in the data tables by 1.26.

The nominal travel life can be calculated by the following equation.

$$L = \left( \frac{C}{P} \right)^3 \times 50 \qquad L_{100} = \left( \frac{C_{100}}{P} \right)^3 \times 100$$

- L = Nominal life in km (standard 50)
- L<sub>100</sub> = Nominal life in km (100)
- C = Basic dynamic load rating (at 50km) in Newtons
- C<sub>100</sub> = Dynamic load rating (at 100km) in Newtons  $\left( = \frac{C}{1.26} \right)$
- P = Applied load (Newtons)

Other factors will affect the life as follows.

$$L = \left( \frac{f_h \times f_t \times f_c}{f_w} \times \frac{C}{P} \right)^3 \times 50 \qquad L_{100} = \left( \frac{f_h \times f_t \times f_c}{f_w} \times \frac{C_{100}}{P} \right)^3 \times 100$$

- f<sub>h</sub> = Hardness factor
- f<sub>w</sub> = Load factor
- f<sub>t</sub> = Temperature factor
- f<sub>c</sub> = Contact factor

From the above equations, when the stroke and frequency are constant, the travel life can be calculated by the following equation.

### Travel life

$$L_n = \frac{L \times 10^6}{2 \times L_s \times n_o \times 60}$$

- L<sub>s</sub> = Stroke (km)
- n<sub>o</sub> = Number of strokes per minute
- L<sub>n</sub> = Travel life
- L = Nominal life (km)



#### Calculation example

The maximum applied load and the travel life are the most important factors for choosing the correct size of linear ball bushings. Below are sample calculations for expected travel life and selection of the correctly sized linear ball bushing.

#### Working conditions

Applied load (P):	250N
Stroke (L <sub>s</sub> ):	0,25 m
Number of strokes per minute (n <sub>o</sub> ):	60
Shaft hardness:	HRC 60 (f <sub>h</sub> = 1,0)
Operating speed (V):	2 x L <sub>s</sub> x n <sub>o</sub>
	2 x 0,25 x 60
	30,000 mm/min (f <sub>w</sub> = 1,6)

other factors (f<sub>c</sub>, f<sub>t</sub>) are considered as 1,0

#### Calculation of expected travel life

Assuming the basic dynamic load rating is based on travel life of 50km and all other factors are 1,0, you choose the linear bushing size for the life required.

Let's try Superball bushing L1740.020 with the above working conditions.

$$L = \left( \frac{1,0 \times 1,0 \times 1,0}{1,6} \times \frac{2,580}{250} \right)^3 \times 50 \quad L_n = \frac{13,417 \times 10^6}{2 \times 0,25 \times 60 \times 60}$$

$$= 13,417 \text{ km} \quad = 7,454 \text{ hours}$$

#### Choosing the correct linear ball bushing

Let's assume our design travel life is 15,000 hours.

$$L = 15,000 \times 2 \times 0,250 \times 10^{-6} \times 60 \times 60$$

$$= 27,000 \text{ km; and therefore}$$

$$C = \frac{250 \times 1,6}{1,0 \times 1,0 \times 1,0} \times \sqrt[3]{\frac{27,000}{50}}$$

$$= 3,257 \text{ N}$$

Choosing type L1740 and referring to the table, the correct Superball bushing for the above condition is L1740.025 which has 3,800N as the basic dynamic load rating.



### Superball linear ball bushings

- 3 x the load rating and 27 x the travel life of conventional linear bushings
- Self-aligning feature



### Features

#### Higher load ratings

The uniquely designed ball plate (in the outside diameter of the bushing), is made of hardened steel. The precision ground groove is slightly larger than the ball size, which provides greater contact area between the balls and the ball plate, and as a result, provides 3 x higher load ratings of conventional linear bushings.

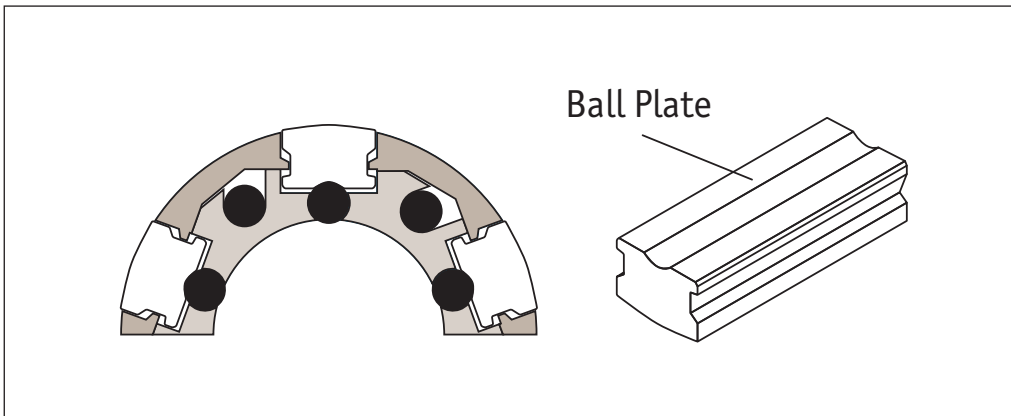

Ball Plate

#### Self-alignment

The ball plate has a convex shape to provide a pivot point at the centre which allows self-alignment up to  $\pm 0.5^\circ$ . This self-alignment capability eliminates any possibility of edge pressure caused by inaccurate machining, errors on mounting, or shaft deflection.

#### Tolerance of shaft and housing bore

Part no.	Shaft		Housing	
	Shaft $\varnothing d_1$	Tol. h6 $\mu$	Housing bore $\varnothing d_2$	Tol. H7 $\mu$
L1740.010	10	+0 to -9	19	+21 to -0
L1740.012	12	+0 to -11	22	
L1740.016	16		26	
L1740.020	20	+0 to -13	32	+25 to -0
L1740.025	25		40	
L1740.030	30		47	
L1740.040	40		62	
L1740.050	50	+0 to -16	75	+30 to -0