

P4074

Material

Pin, Body & Shackle: heat treated steel, tempered, manganese phosphated.
Actuation Button: aluminium, red anodised.
Spring: stainless steel.

Technical Notes

Pressing = unlocking.
Releasing = locking.
Lifts forces up to 4.8kN (with a 5 fold in-built safety factor).

Temperature range up to +250°C.

Easy installation with plain drilled hole to H11 tolerance.

Tips

The design of the safety shackle prevents accidental locking/unlocking. Safety shackle is adjustable and can be used to lift components at 90°, 45° or 180°.

Important Notes

* are values calculated on a 5-fold safety

against breakage.

When machining receiving hole in aluminium we recommend use of hardened bush or collar in receiving hole, see our part no. P4077.

Supplied with TUV test certificate of manufacturing process. Parts not individually tested.

Order No.	l_1	d_1 -0.04 -0.08	d_2	d_3	d_4 min.	l_2	l_3	l_4	l_5	Weight g
P4074.080-010	10	8.0	9.35	21.5	9.85	8.75	25.7	36.0	27.0	218
P4074.080-015	15	8.0	9.35	21.5	9.85	8.75	25.7	36.0	27.0	220
P4074.080-025	25	8.0	9.35	21.5	9.85	8.75	25.7	36.0	27.0	223
P4074.080-035	35	8.0	9.35	21.5	9.85	8.75	25.7	36.0	27.0	226
P4074.083-010	10	8.3	9.65	21.5	10.05	8.75	25.7	36.0	27.0	218
P4074.083-015	15	8.3	9.65	21.5	10.05	8.75	25.7	36.0	27.0	219
P4074.083-025	25	8.3	9.65	21.5	10.05	8.75	25.7	36.0	27.0	223
P4074.083-035	35	8.3	9.65	21.5	10.05	8.75	25.7	36.0	27.0	228
P4074.100-015	15	10.0	11.70	21.5	12.20	10.20	25.7	36.0	27.0	226
P4074.100-025	25	10.0	11.70	21.5	12.20	10.20	25.7	36.0	27.0	238
P4074.100-035	35	10.0	11.70	21.5	12.20	10.20	25.7	36.0	27.0	244
P4074.100-050	50	10.0	11.70	21.5	12.20	10.20	25.7	36.0	27.0	252
P4074.120-015	15	12.0	14.20	21.5	14.70	11.00	25.7	36.0	27.0	238
P4074.120-025	25	12.0	14.20	21.5	14.70	11.00	25.7	36.0	27.0	243
P4074.120-035	35	12.0	14.20	21.5	14.70	11.00	25.7	36.0	27.0	251
P4074.120-050	50	12.0	14.20	21.5	14.70	11.00	25.7	36.0	27.0	268
P4074.138-025	25	13.8	16.20	21.5	16.70	13.00	25.7	36.0	27.0	251
P4074.138-050	50	13.8	16.20	21.5	16.70	13.00	25.7	36.0	27.0	279
P4074.138-075	75	13.8	16.20	21.5	16.70	13.00	25.7	36.0	27.0	309
P4074.160-025	25	16.0	18.60	25.0	19.20	15.10	31.0	44.5	27.0	312
P4074.160-050	50	16.0	18.60	25.0	19.20	15.10	31.0	44.5	27.0	353
P4074.160-075	75	16.0	18.60	25.0	19.20	15.10	31.0	44.5	27.0	388



LIFTING PINS, LIFTING BOLTS & SWING BOLTS

Order No.	l_6	l_7	l_8	F_1 kN	F_2 kN	F_3 kN	x min.	x max.	Location hole tol. H11
P4074.080-010	30	49	87.5	1.5	1.2	0.5	1.5	5	8.0
P4074.080-015	30	49	87.5	1.5	1.2	0.5	1.5	10	8.0
P4074.080-025	30	49	87.5	1.5	1.2	0.5	1.5	15	8.0
P4074.080-035	30	49	87.5	1.5	1.2	0.5	1.5	15	8.0
P4074.083-010	30	49	87.5	1.5	1.2	0.5	1.5	5	8.3
P4074.083-015	30	49	87.5	1.5	1.2	0.5	1.5	10	8.3
P4074.083-025	30	49	87.5	1.5	1.2	0.5	1.5	15	8.3
P4074.083-035	30	49	87.5	1.5	1.2	0.5	1.5	15	8.3
P4074.100-015	30	49	87.5	2.7	2.4	2.1	1.5	10	10.0
P4074.100-025	30	49	87.5	2.7	2.4	2.1	1.5	10	10.0
P4074.100-035	30	49	87.5	2.7	2.4	2.1	1.5	10	10.0
P4074.100-050	30	49	87.5	2.7	2.4	2.1	1.5	10	10.0
P4074.120-015	30	49	87.5	3.5	3.2	2.8	1.5	10	12.0
P4074.120-025	30	49	87.5	3.5	3.2	2.8	1.5	15	12.0
P4074.120-035	30	49	87.5	3.5	3.2	2.8	1.5	15	12.0
P4074.120-050	30	49	87.5	3.5	3.2	2.8	1.5	15	12.0
P4074.138-025	30	49	87.5	3.8	3.5	2.8	1.5	15	13.8
P4074.138-050	30	49	87.5	3.8	3.5	2.8	1.5	35	13.8
P4074.138-075	30	49	87.5	3.8	3.5	2.8	1.5	35	13.8
P4074.160-025	30	49	92.8	4.8	4.5	4.1	1.5	15	16.0
P4074.160-050	30	49	92.8	4.8	4.5	4.1	1.5	35	16.0
P4074.160-075	30	49	92.8	4.8	4.5	4.1	1.5	40	16.0

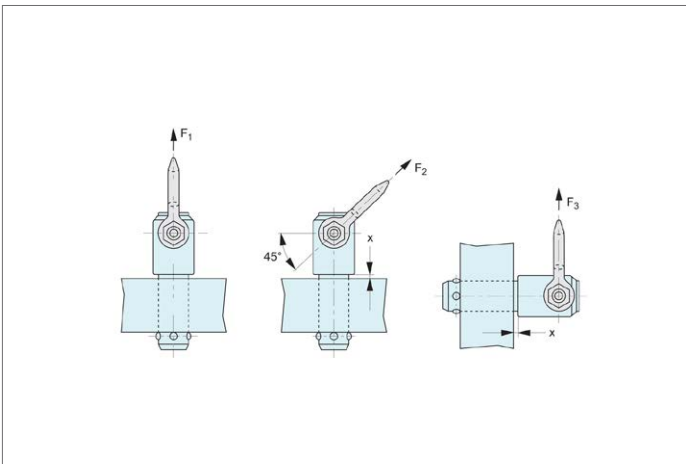



Quick Lift Pins - Self Locking stainless steel

Lifting Pins, Lifting Bolts &

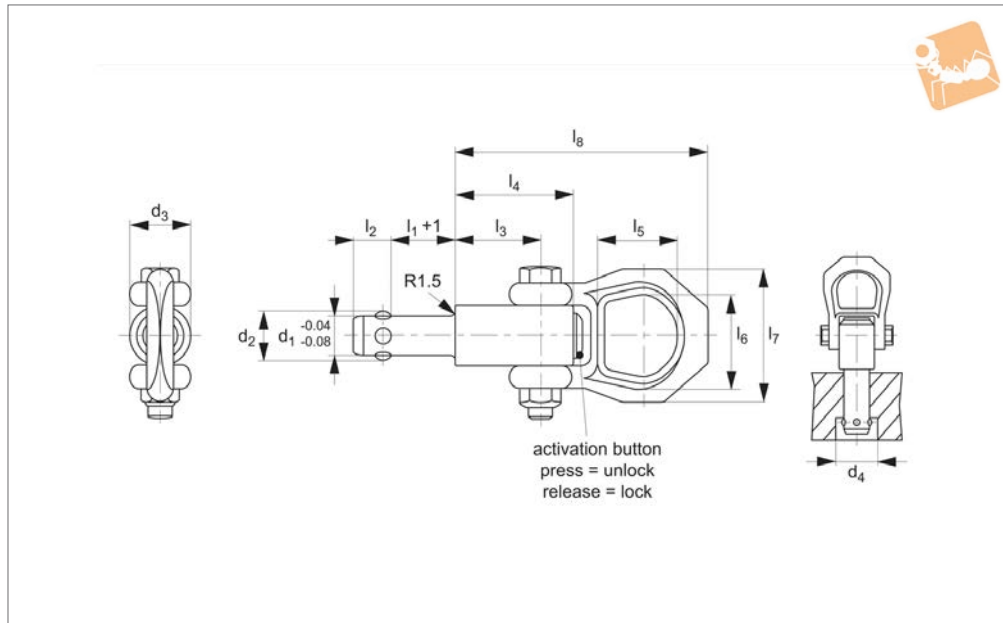

P4075

LIFTING PINS, LIFTING BOLTS & SWING BOLTS

Material

Pin & Body: stainless steel 1.4542 (AISI 630), precipitation hardened.
Shackle: stainless steel 1.4571.
Actuation Button: aluminium, red anodised.
Spring: stainless steel.

Technical Notes

Pressing = unlocking.
Releasing = locking.
Lifts forces up to 4.8kN (with a 5 fold in-

built safety factor).
Temperature range up to +250°C.
Easy installation with plain drilled hole to H11 tolerance.
Corrosion and weather resistant, therefore suitable for outdoor applications.

Tips

The design of the safety shackle prevents accidental locking/unlocking. Safety shackle is adjustable and can be used to lift components at 90°, 45° or 180°.

Important Notes

* are values calculated on a 5-fold safety against breakage.
When machining receiving hole in aluminium we recommend use of hardened bush or collar in receiving hole, see our part no. P4077.
Supplied with TUV test certificate of manufacturing process. Parts not individually tested.

Order No.	l_1	d_1	d_2	d_3	d_4 min.	l_2	l_3	l_4	l_5	Weight g
P4075.080-010	10	8.0	9.35	21.5	9.85	8.75	25.7	36.0	27	221
P4075.080-015	15	8.0	9.35	21.5	9.85	8.75	25.7	36.0	27	222
P4075.080-025	25	8.0	9.35	21.5	9.85	8.75	25.7	36.0	27	225
P4075.080-035	35	8.0	9.35	21.5	9.85	8.75	25.7	36.0	27	229
P4075.083-010	10	8.3	9.65	21.5	10.05	8.75	25.7	36.0	27	222
P4075.083-015	15	8.3	9.65	21.5	10.05	8.75	25.7	36.0	27	223
P4075.083-025	25	8.3	9.65	21.5	10.05	8.75	25.7	36.0	27	225
P4075.083-035	35	8.3	9.65	21.5	10.05	8.75	25.7	36.0	27	231
P4075.100-015	15	10.0	11.70	21.5	12.20	10.20	25.7	36.0	27	233
P4075.100-025	25	10.0	11.70	21.5	12.20	10.20	25.7	36.0	27	243
P4075.100-035	35	10.0	11.70	21.5	12.20	10.20	25.7	36.0	27	250
P4075.100-050	50	10.0	11.70	21.5	12.20	10.20	25.7	36.0	27	257
P4075.120-015	15	12.0	14.20	21.5	14.70	11.00	25.7	36.0	27	246
P4075.120-025	25	12.0	14.20	21.5	14.70	11.00	25.7	36.0	27	255
P4075.120-035	35	12.0	14.20	21.5	14.70	11.00	25.7	36.0	27	265
P4075.120-050	50	12.0	14.20	21.5	14.70	11.00	25.7	36.0	27	273
P4075.138-025	25	13.8	16.20	21.5	16.70	13.00	25.7	36.0	27	255
P4075.138-050	50	13.8	16.20	21.5	16.70	13.00	25.7	36.0	27	283
P4075.138-075	75	13.8	16.20	21.5	16.70	13.00	25.7	36.0	27	311
P4075.160-025	25	16.0	18.60	25.0	19.20	15.10	31.0	44.5	27	313
P4075.160-050	50	16.0	18.60	25.0	19.20	15.10	31.0	44.5	27	367
P4075.160-075	75	16.0	18.60	25.0	19.20	15.10	31.0	44.5	27	403
P4075.200-050	50	20.0	24.50	30.0	25.00	19.70	36.5	52.0	32.6	607



Order No.	l ₆	l ₇	l ₈	F ₁ kN	F ₂ kN	F ₃ kN	x min.	x max.	Location hole dia. tol. H11
P4075.080-010	30	49	87.5	1.5	1.2	0.5	1.5	5	8.0
P4075.080-015	30	49	87.5	1.5	1.2	0.5	1.5	10	8.0
P4075.080-025	30	49	87.5	1.5	1.2	0.5	1.5	15	8.0
P4075.080-035	30	49	87.5	1.5	1.2	0.5	1.5	15	8.0
P4075.083-010	30	49	87.5	1.5	1.2	0.5	1.5	5	8.3
P4075.083-015	30	49	87.5	1.5	1.2	0.5	1.5	10	8.3
P4075.083-025	30	49	87.5	1.5	1.2	0.5	1.5	15	8.3
P4075.083-035	30	49	87.5	1.5	1.2	0.5	1.5	15	8.3
P4075.100-015	30	49	87.5	2.7	2.4	2.1	1.5	10	10.0
P4075.100-025	30	49	87.5	2.7	2.4	2.1	1.5	10	10.0
P4075.100-035	30	49	87.5	2.7	2.4	2.1	1.5	10	10.0
P4075.100-050	30	49	87.5	2.7	2.4	2.1	1.5	10	10.0
P4075.120-015	30	49	87.5	3.5	3.2	2.8	1.5	10	12.0
P4075.120-025	30	49	87.5	3.5	3.2	2.8	1.5	15	12.0
P4075.120-035	30	49	87.5	3.5	3.2	2.8	1.5	15	12.0
P4075.120-050	30	49	87.5	3.5	3.2	2.8	1.5	15	12.0
P4075.138-025	30	49	87.5	3.8	3.5	2.8	1.5	15	13.8
P4075.138-050	30	49	87.5	3.8	3.5	2.8	1.5	35	13.8
P4075.138-075	30	49	87.5	3.8	3.5	2.8	1.5	35	13.8
P4075.160-025	30	49	92.8	4.8	4.5	4.1	1.5	15	16.0
P4075.160-050	30	49	92.8	4.8	4.5	4.1	1.5	35	16.0
P4075.160-075	30	49	92.8	4.8	4.5	4.1	1.5	40	16.0
P4075.200-050	36	56	114.0	10.0	8.5	6.5	1.5	25	20.0

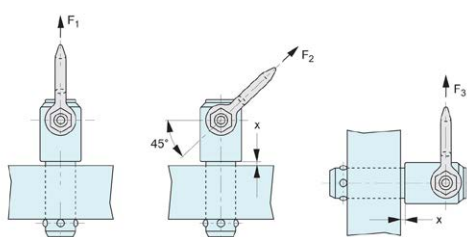



Danger!

Self-locking quick lift pins are designed to lift and hold point loads not people.

Self-locking quick lift pins are not suited for rotating loads.

Dirt and debris etc can affect the performance of the pins.

Using damaged self-locking pins can be very dangerous. Before each use carefully inspect the pins (damage, deformities, signs of stress, corrosion, check unlocking and locking function, loss of balls etc. Check full movement of shackle. Withdraw any defective pins from service immediately.

To release the balls, press button A. To lock the balls, release button A.

The load figures F_1 , F_2 and F_3 apply only to lifting applications used with a steel retainer, and an "x" min of 1.5mm.

Inspect before and after every use. For maintenance – take the out of service after 12 months for inspection by qualified personnel.

Operating Instructions P4074 and P4075

Note: The full shaft must be engaged. Longer shaft lengths can be supplied on request or a bolt and washer/nut combination can be used.

- Ensure all lifting pins are CE marked.
- Ensure they are handled by qualified personnel.
- Refer to the operating instructions particularly with regards to product selection, any possibility of the load swivelling, the effect of lifting angles on the load capacity (see relevant tables), etc.
- Never allow any personnel underneath a suspended load.
- Always heed the load rating of the lifting pin.
- Always perform a visual inspection of the lifting pins prior to use. Checking for any damage to thread and/or swivelling system. Check for wear or corrosion, signs of stress or bending.
- Ensure a yearly full service inspection is performed.
- Always ensure the full bottom face of the lifting pin shoulder is in contact with a smooth, square surface.
- Ensure full and unrestricted movement of the lifting pin in all directions.
- Before each lift ensure the correct orientation of the shackle in the lift direction.
- Avoid using our standard steel lifting pins in corrosive environments eg. sandy, chemical, acid, moisture etc. In this case consider using our stainless steel lifting pins (P4075).

Notes

