



Single swivel

Threads M8 – M48
Loads 0,3 tons
to 15 tons



Double swivel

Threads M4 – M100
Loads 0,05 tons
to 50 tons

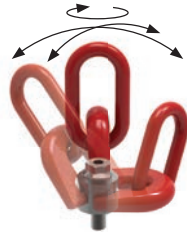

Triple swivel

Threads M8 – M56
Loads 0,3 tons
to 22 tons

Introduction to swivel lifting rings and Lifting Bolts (P4002-P4055)

Our swivel lifting rings fully comply with the EC directive 2006/42/EC. They are CE marked and are supplied with a Certificate of Conformity. There is a 100% check on anti-cracking, a proof load test of 2.5 x load limit and a safety factor of 5 on most parts. Each ring is individually marked to ensure full product traceability.

The Swivel Lifting Rings come in three main forms – depending on the number of axis required to swivel. The most popular type is the double swivel rings.

Other Standard Lifting Bolts

Standard lifting bolts (to DIN 580 and DIN 582) (P4040-P4048)

These are CE marked and are available with male or female threads in either steel or stainless steel (A4 AISI 316). They are meant only for linear loading of the bolts at a maximum angle of 45° from the thread. They are not meant for loads that might swivel.

These are supplied with a generic CE Certificate of Conformity stating that the parts have been manufactured to the relevant DIN standard and therefore suitable for lifting.

High-tensile lifting bolts (P4054-P4055)

The High-tensile lifting bolts are similar to the standard lifting bolts but are rated at higher loads and can lift loads at up to 90° from the thread. They are not meant for loads that might swivel.



Standard lifting bolts
DIN 580 & DIN 582
P4040-P4048

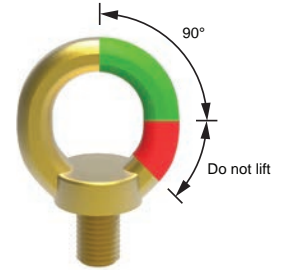

Hi-tensile lifting bolts
P4054-P4055

Swivel lifting rings operating instructions.

Please follow these instructions carefully.

- Ensure all lifting bolts are CE marked.
- Ensure they are handled by qualified personnel.
- Refer to the operating instructions particularly with regards to product selection, any possibility of the load swivelling, the effect of lifting angles on the load capacity (see relevant tables), etc.
- Never allow any personnel underneath a suspended load.
- Always heed the load rating of the lifting bolt.
- Always perform a visual inspection of the lifting rings prior to use. Checking for any damage to thread and/or swivelling system. Check for wear or corrosion, signs of stress or bending. Check CE mark and load rating.
- Ensure a yearly full service inspection is performed.
- Always ensure the full bottom face of the lifting bolts is in contact with a smooth, square surface.
- Ensure bolt is tightened to the correct torque.
- Ensure full and unrestricted movement of the lifting ring in all directions.
- Before each lift ensure the correct orientation of the shackle in the lift direction.
- Avoid using our standard steel lifting rings in corrosive environments eg sandy, chemical, acid, moisture etc. In this case consider using our stainless steel lifting rings.

- Note the thread length requirements:
 - 1 x thread diameter for steel (ST37 min.).
 - 1.25 x thread diameter for cast iron.
 - 2 x thread diameter for aluminium.
 - 2.5 x thread diameter for other light metals.
 - If fixing into low resistance material it is better to allow for a bigger diameter thread to compensate for the lower material resistance.

Note: The full thread must be engaged. Longer thread lengths can be supplied on request or a bolt and washer/nut combination can be used.





P0070.A2

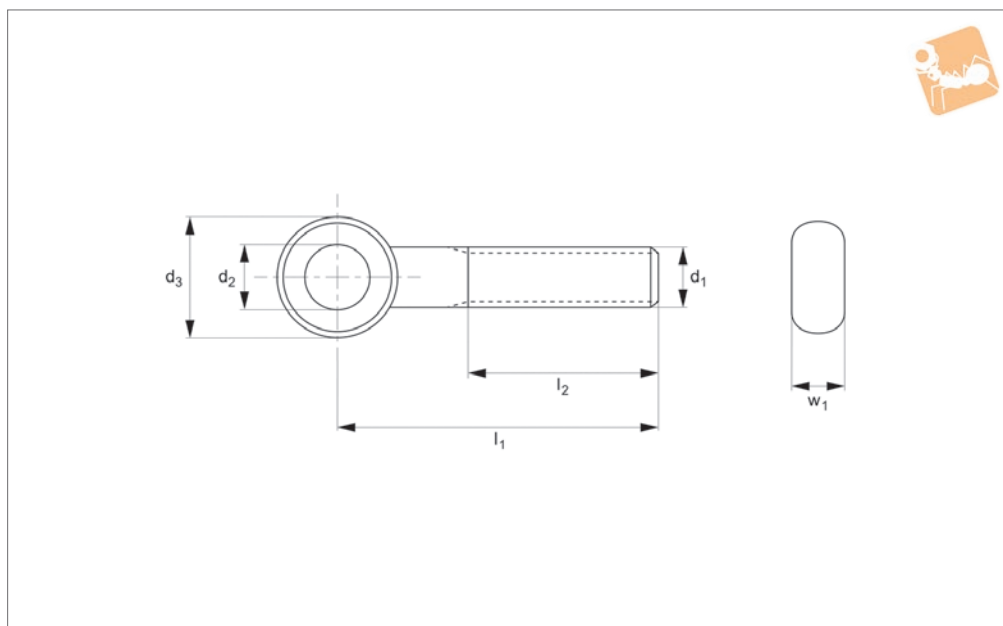

Material

Stainless steel (A2, AISI 303).

Technical Notes

To DIN 444 B.

Order No.	d ₁ tol. H9	l ₁	d ₂ tol. H7	d ₃	l ₂	w ₁ max.
P0070.060-040-A2	M6	40	6	14	18	7
P0070.060-050-A2	M6	50	6	14	18	7
P0070.060-060-A2	M6	60	6	14	18	7
P0070.080-030-A2	M8	30	8	18	22	9
P0070.080-040-A2	M8	40	8	18	22	9
P0070.080-050-A2	M8	50	8	18	22	9
P0070.080-060-A2	M8	60	8	18	22	9
P0070.080-070-A2	M8	70	8	18	22	9
P0070.080-075-A2	M8	75	8	18	22	9
P0070.080-080-A2	M8	80	8	18	22	9
P0070.080-090-A2	M8	90	8	18	22	9
P0070.080-100-A2	M8	100	8	18	22	9
P0070.100-040-A2	M10	40	10	20	26	12
P0070.100-050-A2	M10	50	10	20	26	12
P0070.100-060-A2	M10	60	10	20	26	12
P0070.100-070-A2	M10	70	10	20	26	12
P0070.100-080-A2	M10	80	10	20	26	12
P0070.100-090-A2	M10	90	10	20	26	12
P0070.100-100-A2	M10	100	10	20	26	12
P0070.100-120-A2	M10	120	10	20	26	12
P0070.120-040-A2	M12	40	12	25	30	14
P0070.120-050-A2	M12	50	12	25	30	14
P0070.120-060-A2	M12	60	12	25	30	14
P0070.120-070-A2	M12	70	12	25	30	14
P0070.120-080-A2	M12	80	12	25	30	14
P0070.120-100-A2	M12	100	12	25	30	14
P0070.120-120-A2	M12	120	12	25	30	14
P0070.120-130-A2	M12	130	12	25	30	14
P0070.120-140-A2	M12	140	12	25	30	14
P0070.120-150-A2	M12	150	12	25	30	14
P0070.160-060-A2	M16	60	16	32	38	17
P0070.160-070-A2	M16	70	16	32	38	17
P0070.160-080-A2	M16	80	16	32	38	17
P0070.160-090-A2	M16	90	16	32	38	17



Swing Bolts

A2 stainless

Lifting Pins, Lifting Bolts &

Order No.	d ₁ tol. H9	l ₁	d ₂ tol. H7	d ₃	l ₂	w ₁ max.
P0070.160-100-A2	M16	100	16	32	38	17
P0070.160-110-A2	M16	110	16	32	38	17
P0070.160-120-A2	M16	120	16	32	38	17
P0070.160-130-A2	M16	130	16	32	38	17
P0070.160-140-A2	M16	140	16	32	38	17
P0070.160-150-A2	M16	150	16	32	38	17
P0070.200-075-A2	M20	75	18	40	46	22
P0070.200-080-A2	M20	80	18	40	46	22
P0070.200-090-A2	M20	90	18	40	46	22
P0070.200-100-A2	M20	100	18	40	46	22
P0070.200-110-A2	M20	110	18	40	46	22
P0070.200-120-A2	M20	120	18	40	46	22
P0070.200-130-A2	M20	130	18	40	46	22
P0070.200-140-A2	M20	140	18	40	46	22
P0070.200-150-A2	M20	150	18	40	46	22
P0070.200-160-A2	M20	160	18	40	46	22
P0070.240-080-A2	M24	80	22	45	54	25
P0070.240-090-A2	M24	90	22	45	54	25
P0070.240-100-A2	M24	100	22	45	54	25
P0070.240-110-A2	M24	110	22	45	54	25
P0070.240-120-A2	M24	120	22	45	54	25
P0070.240-130-A2	M24	130	22	45	54	25
P0070.240-140-A2	M24	140	22	45	54	25
P0070.240-150-A2	M24	150	22	45	54	25
P0070.240-160-A2	M24	160	22	45	54	25

LIFTING PINS, LIFTING BOLTS & SWING BOLTS



P0070.A4

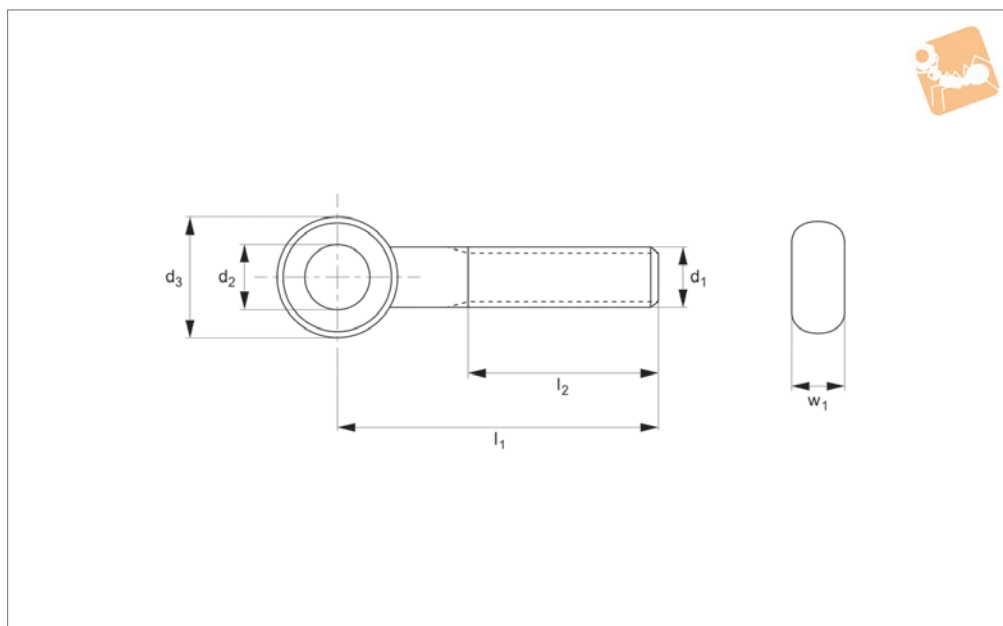

Material

Stainless steel (A4, AISI 316).

Technical Notes

To DIN 444 B.

Order No.	d ₁ tol. H9	l ₁	d ₂ tol. H7	d ₃	l ₂	w ₁ max.
P0070.060-030-A4	M6	30	6	14	18	7
P0070.060-040-A4	M6	40	6	14	18	7
P0070.060-050-A4	M6	50	6	14	18	7
P0070.060-060-A4	M6	60	6	14	18	7
P0070.080-030-A4	M8	30	8	18	22	9
P0070.080-040-A4	M8	40	8	18	22	9
P0070.080-050-A4	M8	50	8	18	22	9
P0070.080-060-A4	M8	60	8	18	22	9
P0070.080-070-A4	M8	70	8	18	22	9
P0070.080-080-A4	M8	80	8	18	22	9
P0070.080-090-A4	M8	90	8	18	22	9
P0070.080-100-A4	M8	100	8	18	22	9
P0070.100-040-A4	M10	40	10	20	26	12
P0070.100-050-A4	M10	50	10	20	26	12
P0070.100-060-A4	M10	60	10	20	26	12
P0070.100-070-A4	M10	70	10	20	26	12
P0070.100-080-A4	M10	80	10	20	26	12
P0070.100-090-A4	M10	90	10	20	26	12
P0070.100-100-A4	M10	100	10	20	26	12
P0070.120-040-A4	M12	40	12	25	30	14
P0070.120-050-A4	M12	50	12	25	30	14
P0070.120-060-A4	M12	60	12	25	30	14
P0070.120-070-A4	M12	70	12	25	30	14
P0070.120-080-A4	M12	80	12	25	30	14
P0070.120-090-A4	M12	90	12	25	30	14
P0070.120-100-A4	M12	100	12	25	30	14
P0070.120-120-A4	M12	120	12	25	30	14
P0070.120-130-A4	M12	130	12	25	30	14
P0070.120-150-A4	M12	150	12	25	30	14
P0070.160-070-A4	M16	70	16	32	38	17
P0070.160-080-A4	M16	80	16	32	38	17
P0070.160-090-A4	M16	90	16	32	38	17
P0070.160-100-A4	M16	100	16	32	38	17
P0070.160-120-A4	M16	120	16	32	38	17



Swing Bolts A4 stainless

Lifting Pins, Lifting Bolts &

Order No.	d ₁ tol. H9	l ₁	d ₂ tol. H7	d ₃	l ₂	w ₁ max.
P0070.160-130-A4	M16	130	16	32	38	17
P0070.200-080-A4	M20	80	18	40	46	22
P0070.200-090-A4	M20	90	18	40	46	22
P0070.200-100-A4	M20	100	18	40	46	22
P0070.200-120-A4	M20	120	18	40	46	22
P0070.240-100-A4	M24	100	22	45	54	25
P0070.240-120-A4	M24	120	22	45	54	25
P0070.240-140-A4	M24	140	22	45	54	25

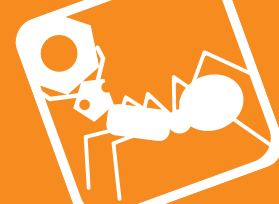

P0070.BR

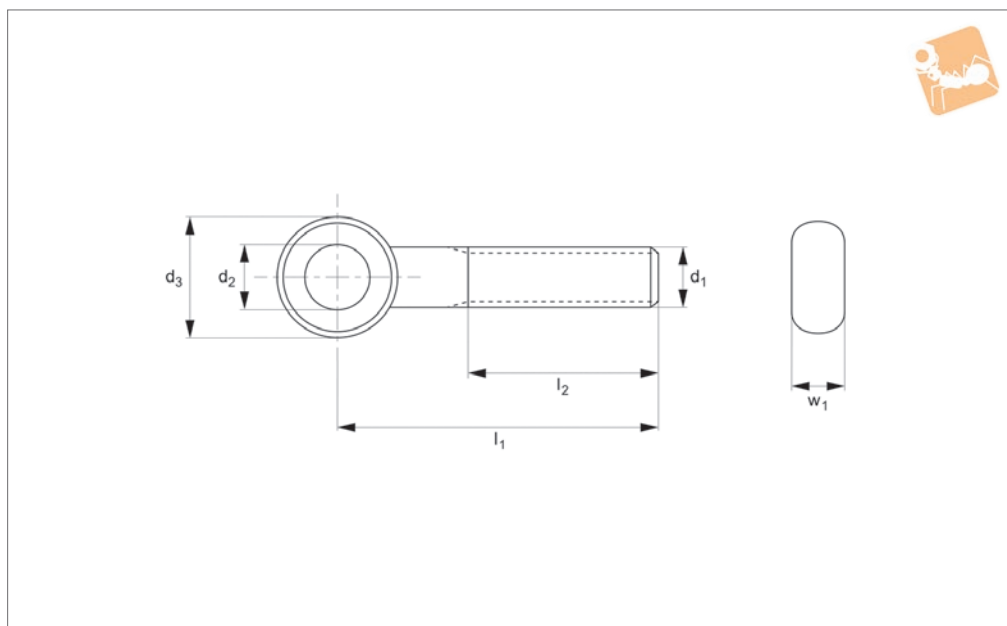

Material
Brass.

Technical Notes
To DIN 444 B.

Order No.	d ₁ tol. H9	l ₁	d ₂ tol. H7	d ₃	l ₂	w ₁ max.
P0070.060-030-BR	M6	30	6	14	18	7
P0070.060-040-BR	M6	40	6	14	18	7
P0070.060-050-BR	M6	50	6	14	18	7
P0070.060-060-BR	M6	60	6	14	18	7
P0070.080-030-BR	M8	30	8	18	22	9
P0070.080-040-BR	M8	40	8	18	22	9
P0070.080-050-BR	M8	50	8	18	22	9
P0070.080-060-BR	M8	60	8	18	22	9
P0070.080-080-BR	M8	80	8	18	22	9
P0070.080-100-BR	M8	100	8	18	22	9
P0070.100-050-BR	M10	50	10	20	26	12
P0070.100-060-BR	M10	60	10	20	26	12
P0070.100-080-BR	M10	80	10	20	26	12
P0070.100-120-BR	M10	100	10	20	26	12
P0070.100-100-BR	M10	120	10	20	26	12
P0070.120-040-BR	M12	40	12	25	30	14
P0070.120-050-BR	M12	50	12	25	30	14
P0070.120-060-BR	M12	60	12	25	30	14
P0070.120-080-BR	M12	80	12	25	30	14
P0070.120-100-BR	M12	100	12	25	30	14
P0070.120-120-BR	M12	120	12	25	30	14
P0070.160-060-BR	M16	60	16	32	38	17
P0070.160-080-BR	M16	80	16	32	38	17
P0070.160-100-BR	M16	100	16	32	38	17
P0070.160-120-BR	M16	120	16	32	38	17
P0070.200-100-BR	M20	100	18	40	46	22
P0070.200-120-BR	M20	120	18	40	46	22
P0070.200-140-BR	M20	140	18	40	46	22
P0070.200-160-BR	M20	160	18	40	46	22



Swing Bolts

Steel - self-colour

Lifting Pins, Lifting Bolts &

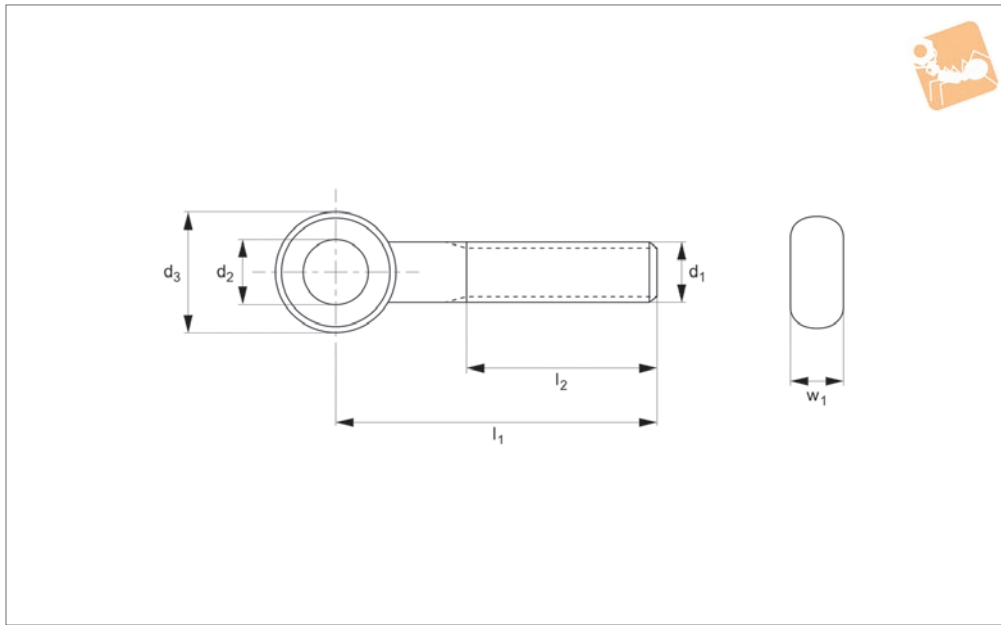

P0070.SC

LIFTING PINS, LIFTING BOLTS & SWING BOLTS

Material

Steel, self-colour (class 4.6).

Technical Notes

To DIN 444 B.

Order No.	d ₁	l ₁	d ₂ tol. H7	d ₃	l ₂	w ₁ max.
P0070.060-030-SC	M6	30	6	14	18	7
P0070.060-040-SC	M6	40	6	14	18	7
P0070.060-050-SC	M6	50	6	14	18	7
P0070.060-060-SC	M6	60	6	14	18	7
P0070.080-030-SC	M8	30	8	18	22	9
P0070.080-040-SC	M8	40	8	18	22	9
P0070.080-050-SC	M8	50	8	18	22	9
P0070.080-060-SC	M8	60	8	18	22	9
P0070.080-070-SC	M8	70	8	18	22	9
P0070.080-080-SC	M8	80	8	18	22	9
P0070.080-090-SC	M8	90	8	18	22	9
P0070.080-100-SC	M8	100	8	18	22	9
P0070.080-120-SC	M8	120	8	18	22	9
P0070.100-040-SC	M10	40	10	20	26	12
P0070.100-050-SC	M10	50	10	20	26	12
P0070.100-060-SC	M10	60	10	20	26	12
P0070.100-070-SC	M10	70	10	20	26	12
P0070.100-080-SC	M10	80	10	20	26	12
P0070.100-090-SC	M10	90	10	20	26	12
P0070.100-100-SC	M10	100	10	20	26	12
P0070.100-120-SC	M10	120	10	20	26	12
P0070.120-040-SC	M12	40	12	25	30	14
P0070.120-050-SC	M12	50	12	25	30	14
P0070.120-060-SC	M12	60	12	25	30	14
P0070.120-070-SC	M12	70	12	25	30	14
P0070.120-080-SC	M12	80	12	25	30	14
P0070.120-090-SC	M12	90	12	25	30	14
P0070.120-100-SC	M12	100	12	25	30	14
P0070.120-120-SC	M12	120	12	25	30	14
P0070.120-130-SC	M12	130	12	25	30	14
P0070.120-140-SC	M12	140	12	25	30	14
P0070.120-150-SC	M12	150	12	25	30	14
P0070.160-060-SC	M16	60	16	32	38	17
P0070.160-070-SC	M16	70	16	32	38	17



LIFTING PINS, LIFTING BOLTS & SWING BOLTS

Order No.	d ₁	l ₁	d ₂ tol. H7	d ₃	l ₂	w ₁ max.
P0070.160-080-SC	M16	80	16	32	38	17
P0070.160-090-SC	M16	90	16	32	38	17
P0070.160-100-SC	M16	100	16	32	38	17
P0070.160-120-SC	M16	120	16	32	38	17
P0070.160-130-SC	M16	130	16	32	38	17
P0070.160-140-SC	M16	140	16	32	38	17
P0070.160-150-SC	M16	150	16	32	38	17
P0070.200-080-SC	M20	80	18	40	46	22
P0070.200-090-SC	M20	90	18	40	46	22
P0070.200-100-SC	M20	100	18	40	46	22
P0070.200-120-SC	M20	120	18	40	46	22
P0070.200-130-SC	M20	130	18	40	46	22
P0070.200-140-SC	M20	140	18	40	46	22
P0070.200-150-SC	M20	150	18	40	46	22
P0070.200-160-SC	M20	160	18	40	46	22
P0070.240-080-SC	M24	80	22	45	54	25
P0070.240-100-SC	M24	100	22	45	54	25
P0070.240-120-SC	M24	120	22	45	54	25
P0070.240-130-SC	M24	130	22	45	54	25
P0070.240-140-SC	M24	140	22	45	54	25
P0070.240-150-SC	M24	150	22	45	54	25
P0070.240-160-SC	M24	160	22	45	54	25
P0070.270-080-SC	M27	120	18	40	60	27
P0070.270-090-SC	M27	140	18	40	60	27
P0070.270-100-SC	M27	160	18	40	60	27
P0070.270-120-SC	M27	180	18	40	60	27
P0070.270-130-SC	M27	200	18	40	60	27
P0070.300-120-SC	M30	120	22	45	66	30
P0070.300-140-SC	M30	140	22	45	66	30
P0070.300-160-SC	M30	160	22	45	66	30
P0070.300-180-SC	M30	180	22	45	66	30
P0070.300-200-SC	M30	200	22	45	66	30



Swing Bolts

Steel - zinc-plated

Lifting Pins, Lifting Bolts &

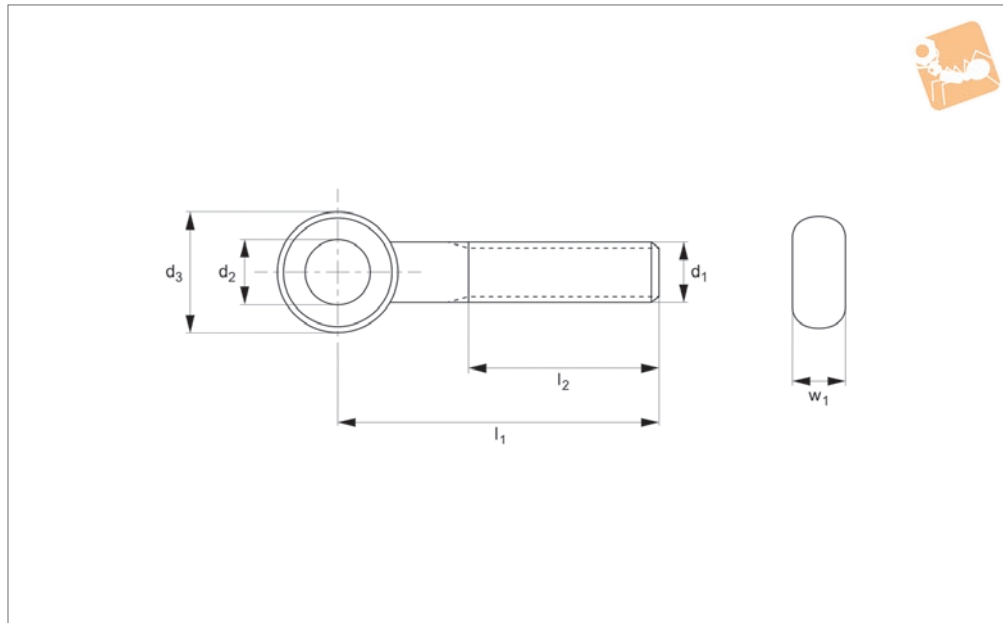

P0070.ZP

LIFTING PINS, LIFTING BOLTS & SWING BOLTS

Material

Steel, zinc-plated (class 4.6).

Technical Notes

To DIN 444 B.

Order No.	d ₁	l ₁	d ₂ tol. H7	d ₃	l ₂	w ₁ max.
P0070.060-030-ZP	M6	30	6	14	18	7
P0070.060-040-ZP	M6	40	6	14	18	7
P0070.060-050-ZP	M6	50	6	14	18	7
P0070.080-040-ZP	M8	40	8	18	22	9
P0070.080-050-ZP	M8	50	8	18	22	9
P0070.080-060-ZP	M8	60	8	18	22	9
P0070.080-080-ZP	M8	80	8	18	22	9
P0070.100-040-ZP	M10	40	10	20	26	12
P0070.100-050-ZP	M10	50	10	20	26	12
P0070.100-060-ZP	M10	60	10	20	26	12
P0070.100-070-ZP	M10	70	10	20	26	12
P0070.100-080-ZP	M10	80	10	20	26	12
P0070.100-090-ZP	M10	90	10	20	26	12
P0070.100-100-ZP	M10	100	10	20	26	12
P0070.100-120-ZP	M10	120	10	20	26	12
P0070.120-060-ZP	M12	60	12	25	30	14
P0070.120-070-ZP	M12	70	12	25	30	14
P0070.120-080-ZP	M12	80	12	25	30	14
P0070.120-090-ZP	M12	90	12	25	30	14
P0070.120-100-ZP	M12	100	12	25	30	14
P0070.120-120-ZP	M12	120	12	25	30	14
P0070.120-140-ZP	M12	140	12	25	30	14
P0070.160-070-ZP	M16	70	16	32	38	17
P0070.160-080-ZP	M16	80	16	32	38	17
P0070.160-090-ZP	M16	90	16	32	38	17
P0070.160-100-ZP	M16	100	16	32	38	17
P0070.160-120-ZP	M16	120	16	32	38	17
P0070.160-140-ZP	M16	140	16	32	38	17
P0070.160-160-ZP	M16	160	16	32	38	17
P0070.160-180-ZP	M16	180	16	32	38	17
P0070.160-200-ZP	M16	200	16	32	38	17
P0070.200-100-ZP	M20	100	18	40	46	22
P0070.200-120-ZP	M20	120	18	40	46	22
P0070.200-140-ZP	M20	140	18	40	46	22



Order No.	d ₁	l ₁	d ₂ tol. H7	d ₃	l ₂	w ₁ max.
P0070.200-160-ZP	M20	160	18	40	46	22
P0070.200-180-ZP	M20	180	18	40	46	22
P0070.200-200-ZP	M20	200	18	40	46	22



Product Overview

Swivel Lifting Rings

Lifting Bolts



Temperature extremes

- 40°C to -20°C Load rating reduces by 20%.
- +200°C to +300°C Load rating reduces by 10%.
- +300°C to +400°C Load rating reduces by 25%.

Rugged

For harsh environments we recommend the use of our stainless steel lifting rings.

Product marking

Compliant with 2006/42/EC, and with individual date of manufacture and batch number.

Complies with 2006/42/CE



P4020

Threads M8 – M30
Loads 0,3 tons to 3 tons.



P4022

Threads M30 – M45
Loads 3,5 tons to 6 tons.



Installation Information

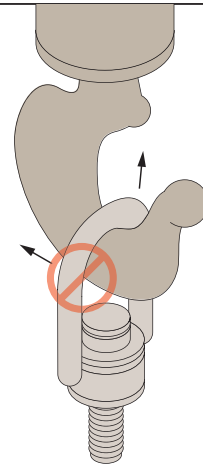

Never use an oversized hook or other lifting device which will pry or tend to open the "U" shaped bar on center pull hoist rings.

Lifting angles

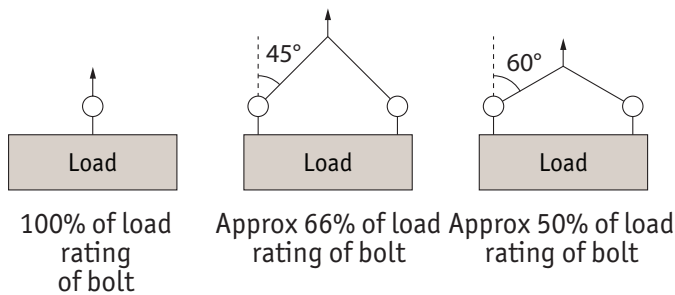

For full information on lifting arrangements see technical pages

Steel and Stainless steel (316) versions



Steel



Stainless (316L)

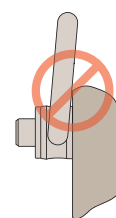

After installation, check the hoist ring to be sure it swivels and pivots freely in all directions. **The side of the ring must not contact anything.**

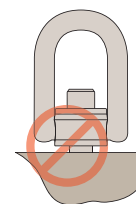

Always ensure full thread engagement when installing hoist rings. Also ensure face is flush.