

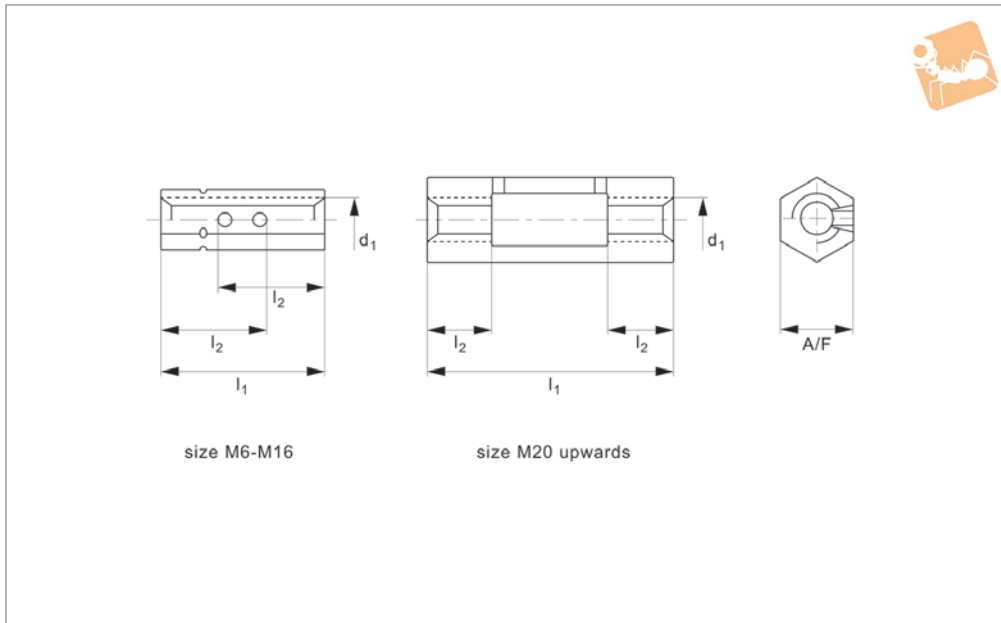

Hexagonal Body Turnbuckles

steel

Turnbuckles

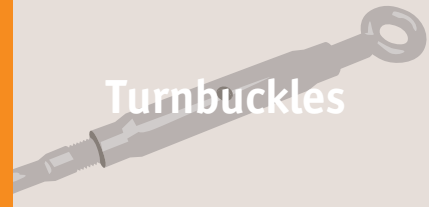

R3825

TURNBUCKLES

Material

Steel (1.0037), zinc-plated.
Hot dip galvanized, available on request providing increased protection against corrosion. Please add -FZ for hot dip galvanized, e.g. R3804.006-FZ.

Technical Notes

To DIN 1479.

Tips

Turnbuckles consist of a metal frame with

right hand thread one end and left hand thread the other end. Used for tensioning by rotating turnbuckle body without twisting attached rope or cable.

Important Notes

L2 dimension indicates the length of thread from each end that has been overcut.

This means you can screw from one end a total of length l2. Please note if screwing in from both ends the length of thread is

half l2.

Sizes M6-M16, have overlapping thread, from M20 middle part is relieved.

Turnbuckles are not to be used for lifting. Only suitable for use in tension.

Order No.	d ₁	l ₁	l ₂	A/F	Adjustment	Weight kg
R3825.006-ZP	M 6	30	22.5	10	15	0.02
R3825.008-ZP	M 8	35	25.0	13	15	0.03
R3825.010-ZP	M10	45	33.0	16	21	0.06
R3825.012-ZP	M12	55	40.0	18	25	0.09
R3825.016-ZP	M16	75	55.0	24	35	0.18
R3825.020-ZP	M20	95	24.0	30	47	0.32
R3825.024-ZP	M24	115	29.0	36	57	0.53
R3825.030-ZP	M30	125	36.0	46	53	1.08



R3826

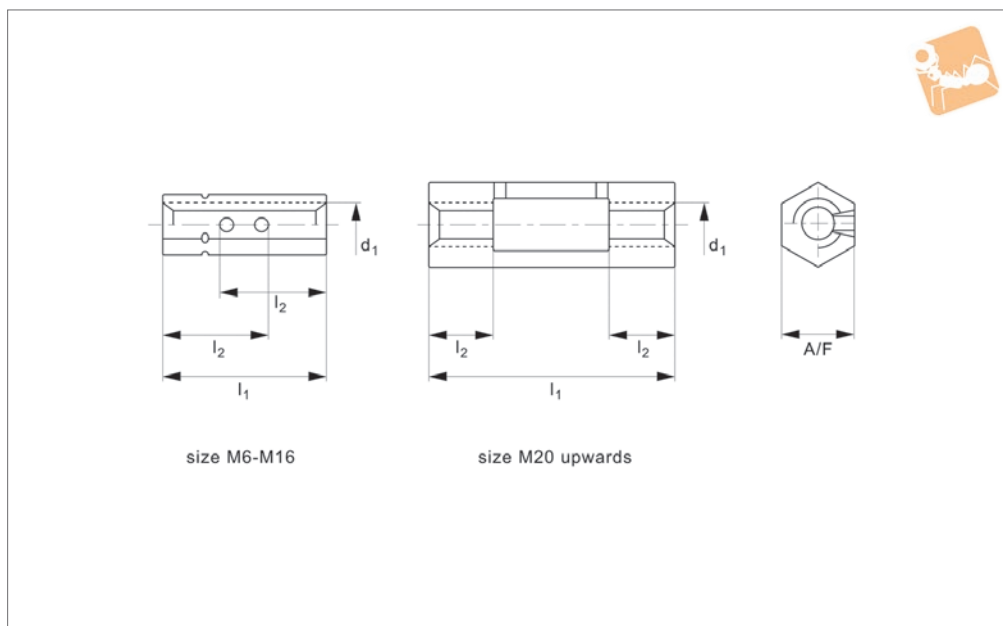

Material
Stainless steel (A4).

Technical Notes
To DIN 1479.

Tips
Turnbuckles consist of a metal frame with right hand thread one end and left hand thread the other end. Used for tensioning

by rotating turnbuckle body without twisting attached rope or cable.

Important Notes
L2 dimension indicates the length of thread from each end that has been overcut.
This means you can screw from one end a total of length l2. Please note if screwing

in from both ends the length of thread is half l2.

Sizes M6-M16, have overlapping thread, from M20 middle part is relieved.

Turnbuckles are not to be used for lifting. Only suitable for use in tension.

Order No.	d ₁	l ₁	l ₂	A/F	Adjustment	Weight kg
R3826.006-A4	M 6	30	22.5	10	15	0.02
R3826.008-A4	M 8	35	25.0	13	15	0.03
R3826.010-A4	M10	45	33.0	16	21	0.06
R3826.012-A4	M12	55	40.0	18	25	0.09
R3826.016-A4	M16	75	55.0	24	35	0.18
R3826.020-A4	M20	95	24.0	30	47	0.32
R3826.024-A4	M24	115	29.0	36	57	0.53
R3826.030-A4	M30	125	36.0	46	53	1.08