

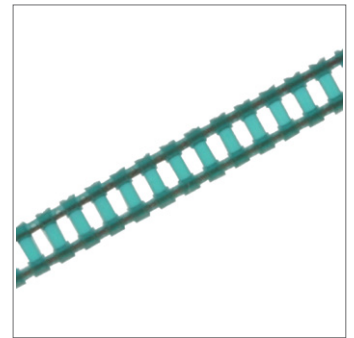

# Gear Drive Chains

2,5mm nominal circular pitch

# Chains, Belts & Pulleys

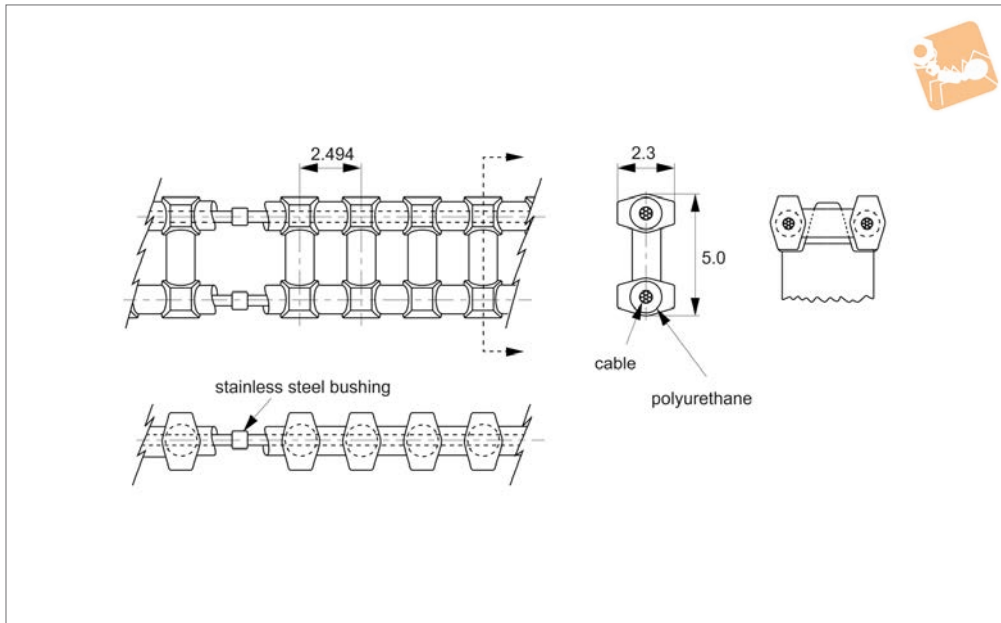

**R1000**

CHAINS, BELTS & PULLEYS

### Material

0.5mm Ø, stainless steel cable, encased in polyurethane (blue).  
Fibre cable core (aramid) also available (particularly suitable for reverse bend applications).  
When ordering aramid core type add suffix -EF to order no.

### Technical Notes

Infinite lengths, silent drive, positive

drive, mass 23 grams/metre, zero backlash, no lubrication, 90A Durometer  
Ultimate tensile strength 130N, (17N/pin) when belt is used in open loop configuration (without splice, no crimp bushing),  
Temperature range: +80°C to -25°C  
Recommended operating load 36N,  
Recommended max. operating speed 1,19m/s.  
Other numbers of pitches available on

request.

### Tips

Reduce operating load rating by 50% for self splices.  
For self splice kit order R1000.SSK.

### Important Notes

Operates with R1001 and R1002 series sprockets.

Order No.	No. of pitches	Length ref.
R1000.049	49	122.2
R1000.052	52	129.7
R1000.053	53	132.2
R1000.064	64	159.6
R1000.067	67	167.1
R1000.075	75	187.0
R1000.080	80	199.5
R1000.095	95	236.9
R1000.112	112	279.3
R1000.126	126	314.2
R1000.128	128	319.2
R1000.144	144	359.1
R1000.158	158	394.1
R1000.176	176	438.9
R1000.189	189	471.4
R1000.208	208	518.8
R1000.220	220	548.7
R1000.240	240	598.6
R1000.252	252	628.5
R1000.272	272	678.4
R1000.283	283	705.8
R1000.304	304	758.2
R1000.315	315	785.6
R1000.336	336	838.0
R1000.346	346	862.9
R1000.377	377	940.2
R1000.400	400	997.6



Order No.	No. of pitches	Length ref.
R1000.408	408	1017.6
R1000.432	432	1077.4
R1000.440	440	1097.4
R1000.464	464	1157.2
R1000.471	471	1174.7
R1000.480	480	1197.1
R1000.512	512	1276.9
R1000.544	544	1356.7
R1000.592	592	1476.4
R1000.608	608	1516.4
R1000-1.5M	-	1,5 metres not spliced
R1000-3.0M	-	3,0 metres not spliced
R1000-7.5M	-	7,5 metres not spliced
R1000-15M	-	15,0 metres not spliced
R1000-30M	-	30,0 metres not spliced



# Gear Drive chains

2,54mm nominal circular pitch



## Chains, Belts & Pulleys

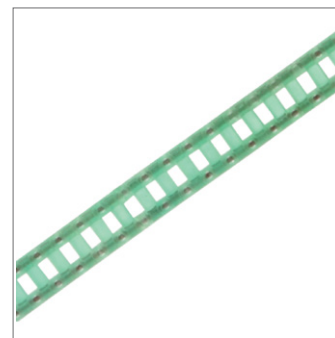
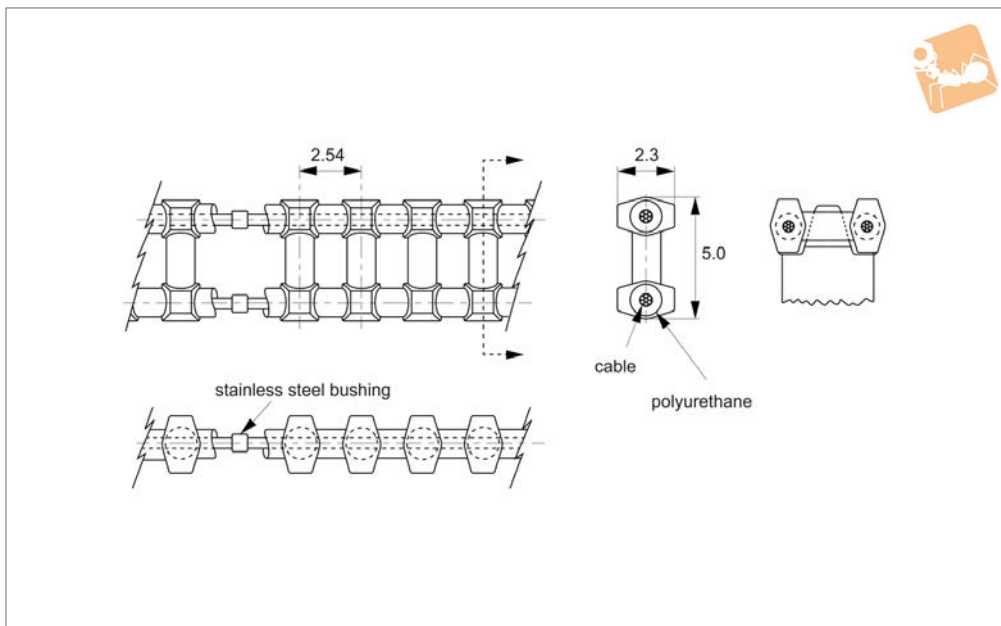

**R1005**

CHAINS, BELTS & PULLEYS

**Material**

0.5mm Ø, stainless steel cable, encased in polyurethane (green).  
 Fibre cable core (aramid) also available (particularly suitable for reverse bend applications).  
 When ordering aramid core type add suffix -EF to order no.

**Technical Notes**

Infinite lengths, Silent drive, positive

drive, mass 12 grams/metre, zero backlash, no lubrication, 90A Durometer, ultimate tensile strength 130N (15N/pin) when belt is used in open loop configuration (without splice, no crimp bushing) Temperature range +80°C to -25°C, Recommended operating load 36N. Recommended max. operating speed 1,91 m/s.  
 Other no's of pitches available on request.

**Tips**

Self splice kit available (R1005.SSK).  
 Reduce operating load rating by 50% for self splices.

**Important Notes**

Operates with R1006 and R1007 series sprockets.

Order No.	No. of pitches	Length ref.
R1005.045	45	114.3
R1005.050	50	127.0
R1005.055	55	139.7
R1005.060	60	152.4
R1005.065	65	165.1
R1005.070	70	177.8
R1005.075	75	190.5
R1005.080	80	203.2
R1005.085	85	215.9
R1005.090	90	228.6
R1005.095	95	241.3
R1005.100	100	254.0
R1005.105	105	266.7
R1005.110	110	279.4
R1005.115	115	292.1
R1005.120	120	304.8
R1005.125	125	317.5
R1005.130	130	330.2
R1005.135	135	342.9
R1005.140	140	355.6
R1005.150	150	381.0
R1005.160	160	406.4
R1005.170	170	431.8
R1005.180	180	457.2
R1005.190	190	482.6
R1005.200	200	508.0
R1005.210	210	533.4



Order No.	No. of pitches	Length ref.
R1005.220	220	558.8
R1005.230	230	584.2
R1005.240	240	609.6
R1005.250	250	635.0
R1005.300	300	762.0
R1005.360	360	914.4
R1005.420	420	1066.8
R1005.480	480	1219.2
R1005.540	540	1371.6
R1005.600	600	1524.0
R1005-1.5M	-	1,5 metres not spliced
R1005-3.0M	-	3,0 metres not spliced
R1005-7.5M	-	7,5 metres not spliced
R1005-15M	-	15,0 metres not spliced
R1005-30M	-	30,0 metres not spliced



# Gear Drive Chains

3,325 circular pitch

# Chains, Belts & Pulleys

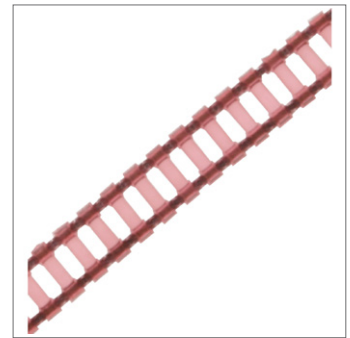
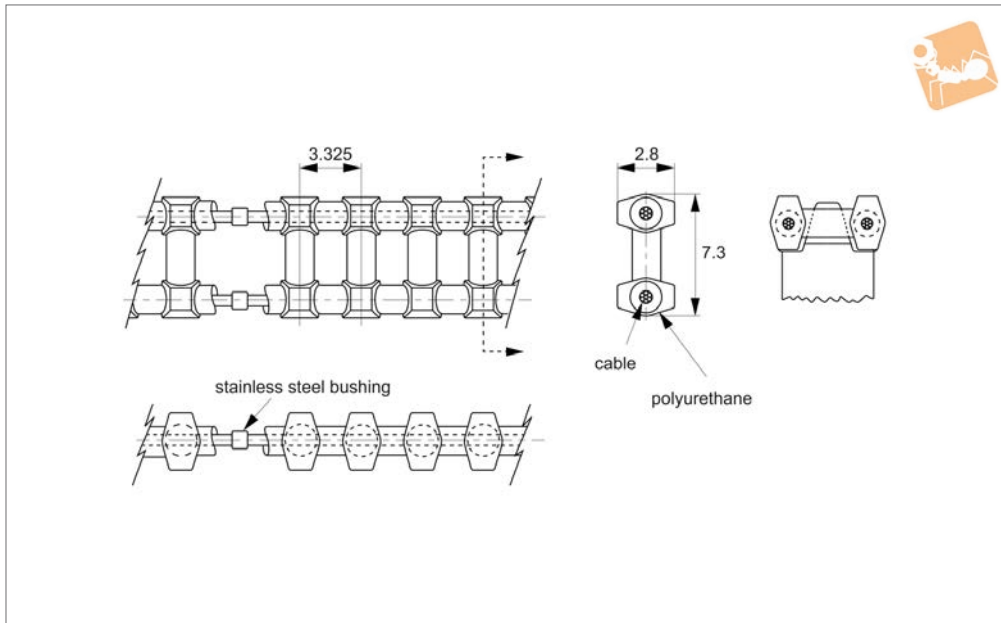

## R1010

CHAINS, BELTS & PULLEYS

### Material

0,8mm Ø, stainless steel cable, encased in polyurethane (red).

Fibre cable core (aramid) also available (particularly suitable for reverse bend applications).

When ordering aramide core type add suffix -EF to order no.

### Technical Notes

Infinite lengths, zero backlash, no lubrica-

tion, mass 13 grams/metre, positive drive, silent drive, extra strong 90A Durometer, Ultimate tensile strength 440N (40N/pin) when belt is used in open loop configuration (without splice, no crimp bushing). Temperature range +80°C to -25°C, Recommended operating load 108N, Recommended max. operating speed 1,91m/s.

Other no's of pitches available on request.

### Tips

Self splice kit available (order no. R1010.SSK).

Reduce operating load rating by 50% for self splices.

### Important Notes

Operates with R1011, R1012 series sprockets.

Order No.	No. of pitches	Length ref.
R1010.050	50	166.3
R1010.052	52	172.9
R1010.054	54	179.6
R1010.056	56	186.2
R1010.058	58	192.9
R1010.060	60	199.5
R1010.062	62	206.2
R1010.064	64	212.8
R1010.066	66	219.5
R1010.068	68	226.1
R1010.070	70	232.8
R1010.075	75	249.4
R1010.080	80	266.0
R1010.085	85	282.6
R1010.090	90	299.3
R1010.095	95	315.9
R1010.100	100	332.5
R1010.105	105	349.1
R1010.110	110	365.8
R1010.115	115	382.4
R1010.120	120	399.0
R1010.130	130	432.3
R1010.140	140	465.5
R1010.150	150	498.8
R1010.160	160	532.0
R1010.170	170	565.3
R1010.180	180	598.5



Order No.	No. of pitches	Length ref.
R1010.190	190	631.8
R1010.200	200	335.0
R1010.220	220	731.5
R1010.240	240	798.0
R1010.260	260	864.5
R1010.280	280	931.0
R1010.300	300	997.5
R1010.320	320	1064.0
R1010.380	380	1263.5
R1010.420	420	1396.5
R1010-1.5M	-	1,5 metres not spliced
R1010-3.0M	-	3,0 metres not spliced
R1010-7.5M	-	7,5 metres not spliced
R1010-15M	-	15,0 metres not spliced
R1010-30M	-	30,0 metres not spliced



# Gear Drive Belt

Ø0,5mm cable, 2,5mm nominal circular pitch

# Chains, Belts & Pulleys

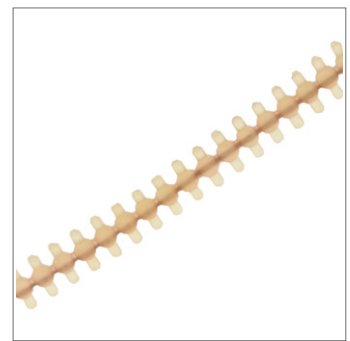
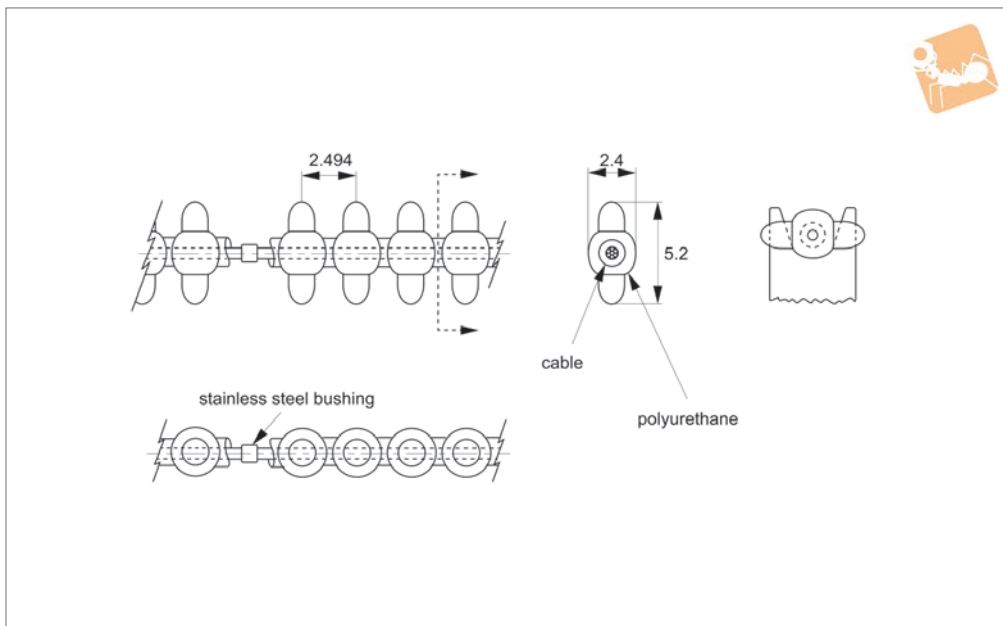

## R1020

CHAINS, BELTS & PULLEYS

### Material

0,5mm Ø stainless steel cable encased in polyurethane (light brown).

Fibre cable core (aramid) also available (particularly suitable for reverse bend applications).

When ordering aramid core type add suffix -EF to order No.

### Technical Notes

Acommodates twists and turns, odd angles, infinite lengths, silent drive, mass

10 grams/metre, positive drive, Zero backlash, no lubrication, 90A Duro-meter.

Ultimate tensile strength 89N, 31N/pin when belt is used in open loop configuration (without splice, no crimp bushing).

Temperature range +80°C to -25°C, recommended operating load 53N.

Recommended max. operating speed 1,91m/s.

Other no's of pitches available on request.

For smaller sizes, please see previous

pages

### Tips

Self splice kit available (order no. R1020.SSK)

Reduce operating load rating by 50% for self splices.

### Important Notes

Operates with R1022 and R1023 series sprockets.

Order No.	No. of pitches	Length ref.
R1020.049	49	122.2
R1020.052	52	129.7
R1020.053	53	132.2
R1020.064	64	159.6
R1020.067	67	167.1
R1020.075	75	187.1
R1020.080	80	199.5
R1020.095	95	236.9
R1020.112	112	279.3
R1020.126	126	314.2
R1020.128	128	319.2
R1020.144	144	359.1
R1020.158	158	394.1
R1020.176	176	438.9
R1020.189	189	471.4
R1020.208	208	518.8
R1020.220	220	548.7
R1020.240	240	598.6
R1020.252	252	628.5
R1020.272	272	678.4
R1020.283	283	705.8
R1020.304	304	758.2
R1020.315	315	785.6
R1020.336	336	838.0
R1020.346	346	862.9



Order No.	No. of pitches	Length ref.
R1020.377	377	940.2
R1020.400	400	997.6
R1020.408	408	1017.6
R1020.432	432	1077.4
R1020.440	440	1097.4
R1020.464	464	1157.2
R1020.471	471	1174.7
R1020.480	480	1197.1
R1020.496	496	1237.0
R1020.512	512	1276.9
R1020.544	544	1356.7
R1020.560	560	1396.6
R1020.576	576	1436.5
R1020.640	640	1596.2
R1020-1.5M	-	1,5 metres not spliced
R1020-3.0M	-	3,0 metres not spliced
R1020-7.5M	-	7,5 metres not spliced
R1020-15M	-	15,0 metres not spliced
R1020-30M	-	30,0 metres not spliced





# Gear Drive Belts

2,54 nominal circular pitch

# Chains, Belts & Pulleys

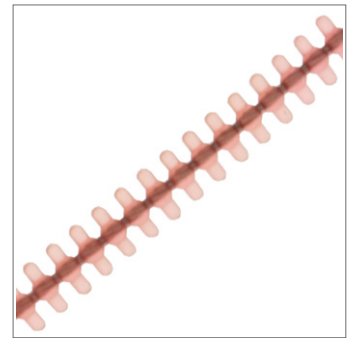
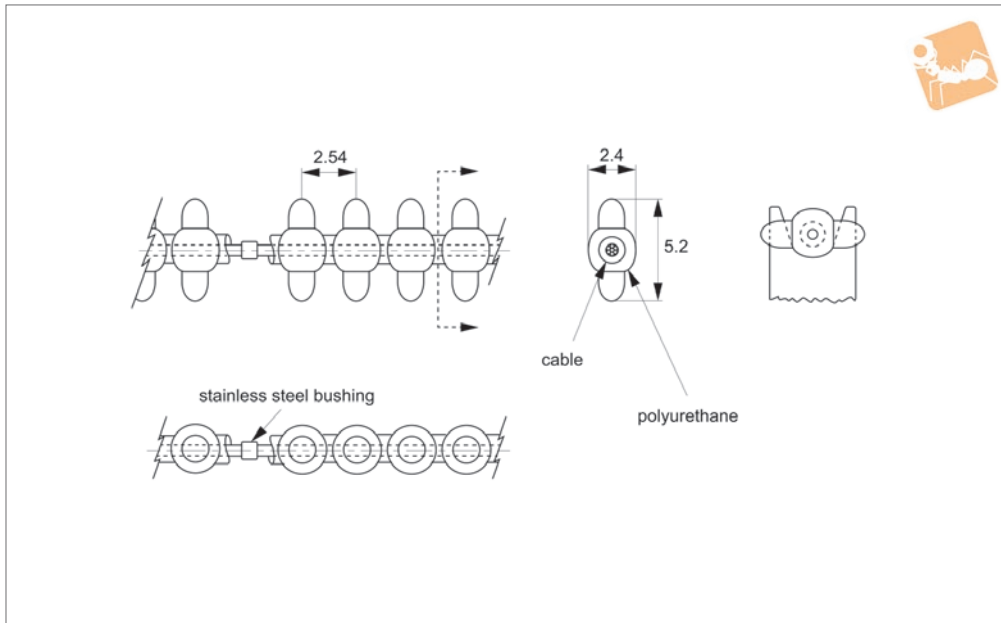

## R1025

CHAINS, BELTS & PULLEYS

### Material

0,8mm Ø stainless steel cable encased in polyurethane (red).

Fibre cable core (aramid) also available (particularly suitable for reverse bend applications).

When ordering aramid core type add suffix -EF to order no.

### Technical Notes

Acommodates twists and turns, odd

angles, infinite lengths, silent drive, mass 10 grams/metre, positive drive, zero backlash, no lubrication, 90A Duro-meter.

Ultimate tensile strength 222N, 40N/pin when belt is used in open loop configuration (without splice, no crimp bushing). Temperature range +80°C to -25°C, recommended operating load 53N. Recommended max. operating speed

1,91m/s.

### Tips

Self splice kits available R1025.SSK. Reduce operating load rating by 50% for field splices.

### Important Notes

Operates with R1026 and R1027 series sprockets.

Order No.	No. of pitches	Length ref.
R1025.050	50	127.0
R1025.052	52	132.1
R1025.054	54	137.2
R1025.056	56	142.2
R1025.058	58	147.3
R1025.060	60	152.4
R1025.065	65	165.1
R1025.070	70	177.8
R1025.075	75	190.5
R1025.080	80	203.2
R1025.085	85	215.9
R1025.090	90	228.6
R1025.100	100	254.0
R1025.110	110	279.4
R1025.120	120	304.8
R1025.130	130	330.2
R1025.140	140	355.6
R1025.150	150	381.0
R1025.160	160	406.4
R1025.170	170	431.8
R1025.180	180	457.2
R1025.190	190	482.6
R1025.200	200	508.0
R1025.210	210	533.4
R1025.220	220	558.8
R1025.230	230	584.2
R1025.240	240	609.6



Order No.	No. of pitches	Length ref.
R1025.250	250	635.0
R1025.260	260	660.4
R1025.270	270	685.8
R1025.280	280	711.2
R1025.300	300	762.0
R1025.350	350	889.0
R1025.400	400	1016.0
R1025.480	480	1143.0
R1025.500	500	1270.0
R1025.800	800	2032.0
R1025-1.5M	-	1,5 metres not spliced
R1025-3.0M	-	3,0 metres not spliced
R1025-7.5M	-	7,5 metres not spliced
R1025-15M	-	15,0 metres not spliced
R1025-30M	-	30,0 metres not spliced



# Gear Drive Belts

3,325 circular pitch

# Chains, Belts & Pulleys

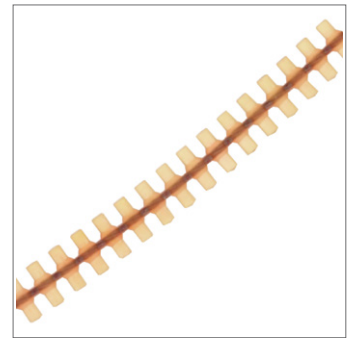
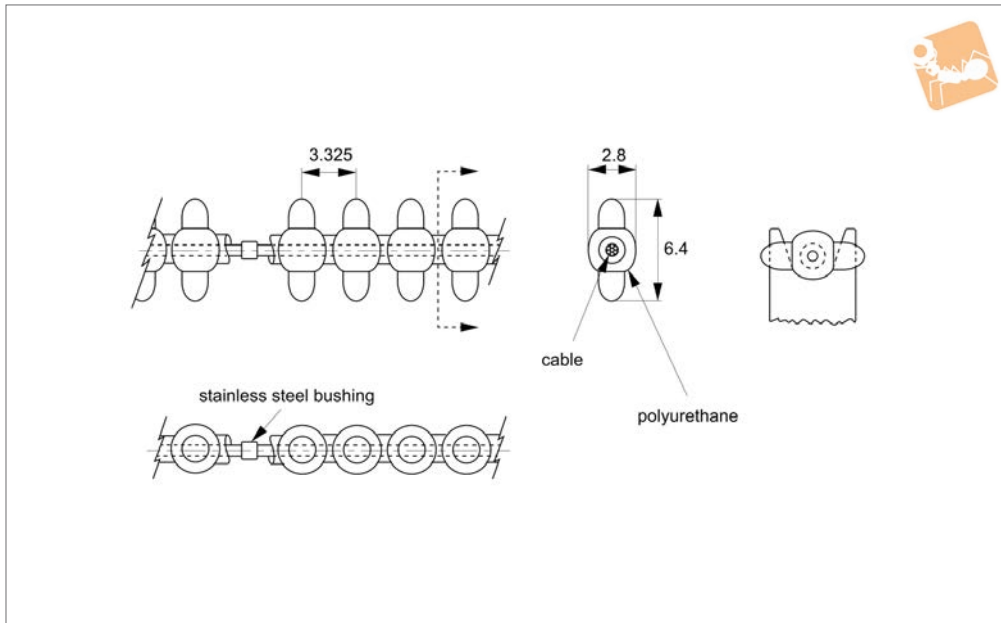

**R1030**

CHAINS, BELTS & PULLEYS

**Material**

0,8mm Ø stainless steel cable encased in polyurethane (red).

Fibre cable core (aramid) also available (particularly suitable for reverse bend applications).

When ordering aramid core type add suffix -EF to order no.

**Technical Notes**

Acommodates twists and turns, odd

angles, infinite lengths, silent drive, mass 12 grams/metre, positive drive, zero backlash, no lubrication, 90A Duro-meter.

Ultimate tensile strength 222N, 40N/pin when belt is used in open loop configuration (without splice, no crimp bushing). Temperature range +80°C to -25°C, recommended operating load 53N.

Recommended max. operating speed

1,91m/s.

**Tips**

Self splice kits available (R1030.SSK). Reduce operating load rating by 50% for self splices.

**Important Notes**

Operates with R1031 and R1032 series sprockets.

Order No.	No. of pitches	Length ref.
R1030.050	50	166.3
R1030.052	52	172.9
R1030.054	54	179.6
R1030.056	56	186.2
R1030.058	58	192.9
R1030.060	60	199.5
R1030.062	62	206.2
R1030.064	64	212.8
R1030.066	66	219.5
R1030.068	68	226.1
R1030.070	70	232.8
R1030.075	75	249.4
R1030.080	80	266.0
R1030.085	85	282.6
R1030.090	90	299.3
R1030.095	95	315.9
R1030.100	100	332.5
R1030.105	105	349.1
R1030.110	110	365.8
R1030.115	115	382.4
R1030.120	120	399.0
R1030.130	130	432.3
R1030.140	140	465.5
R1030.150	150	498.8
R1030.160	160	532.0
R1030.170	170	565.3
R1030.180	180	598.5



Order No.	No. of pitches	Length ref.
R1030.190	190	631.8
R1030.200	200	665.0
R1030.220	220	731.5
R1030.240	240	798.0
R1030.260	260	864.5
R1030.280	280	931.0
R1030.300	300	997.5
R1030.320	320	1064.0
R1030.360	360	1197.0
R1030.420	420	1396.0
R1030-1.5M	-	1,5 metres not spliced
R1030-3.0M	-	3,0 metres not spliced
R1030-7.5M	-	7,5 metres not spliced
R1030-15M	-	15,0 metres not spliced
R1030-30M	-	30,0 metres not spliced



# Cable Chains

4mm nominal circular pitch

# Chains, Belts & Pulleys

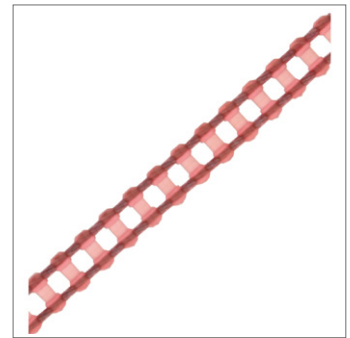
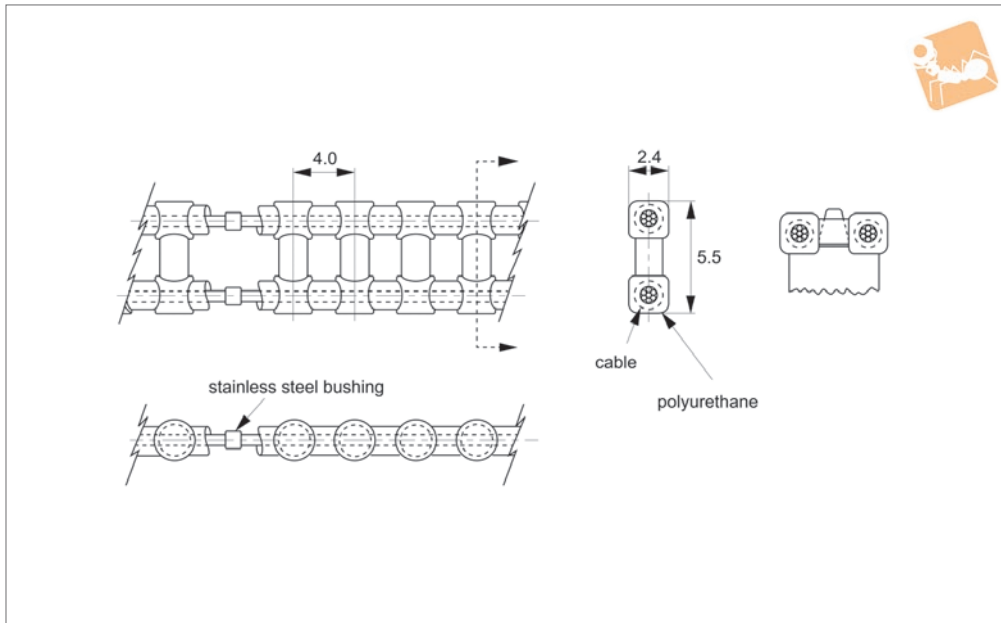

## R1035

CHAINS, BELTS & PULLEYS

### Material

0,8mm Ø stainless steel cable encased in polyurethane (red).  
Fibre cable core (aramid) also available (particularly suitable for reverse bend applications)  
When ordering add suffix -EF to order no.

### Technical Notes

Infinite lengths, silent drive, mass 12 grams/metre, non-magnetic, positive

drive, zero backlash, no lubrication, 90A Durometer.  
Ultimate tensile strength 445N-89N/PIN when belt is used in open loop configuration (without splice, no crimp bushings).  
Temperature range +82°C to -26°C, recommended operating load 111N.  
Recommended max. operating speed 1,91m/s.  
Other no's of pitches available on request.

### Tips

Self splice kits available (order no. R1035.SSK).  
Reduce operating load rating by 50% for self splices

### Important Notes

Operates with R1036, R1037 and R1038 series sprockets.

Order No.	No. of pitches	Length ref.
R1035.030	30	120.0
R1035.035	35	140.0
R1035.040	40	160.0
R1035.045	45	180.0
R1035.050	50	200.0
R1035.055	55	220.0
R1035.060	60	240.0
R1035.070	70	280.0
R1035.080	80	320.0
R1035.090	90	360.0
R1035.100	100	400.0
R1035.110	110	440.0
R1035.120	120	480.0
R1035.130	130	520.0
R1035.140	140	560.0
R1035.150	150	600.0
R1035.160	160	640.0
R1035.170	170	680.0
R1035.180	180	720.0
R1035.190	190	760.0
R1035.200	200	800.0
R1035.210	210	840.0
R1035.220	220	880.0
R1035.230	230	920.0
R1035.240	240	960.0
R1035.250	250	1000.0
R1035.260	260	1040.0



Order No.	No. of pitches	Length ref.
R1035.270	270	1080.0
R1035.280	280	1120.0
R1035.290	290	1160.0
R1035.300	300	1200.0
R1035.310	310	1240.0
R1035.320	320	1280.0
R1035.330	330	1320.0
R1035.340	340	1360.0
R1035.350	350	1520.0
R1035.370	370	1600.0
R1035.400	400	1680.0
R1035.440	440	1760.0
R1035-1.5M	-	1,5 metres not spliced
R1035-3.0M	-	3,0 metres not spliced
R1035-7.5M	-	7,5 metres not spliced
R1035-15M	-	15,0 metres not spliced
R1035-30M	-	30,0 metres not spliced



# 3-D Belts

4mm nominal circular pitch

# Chains, Belts & Pulleys

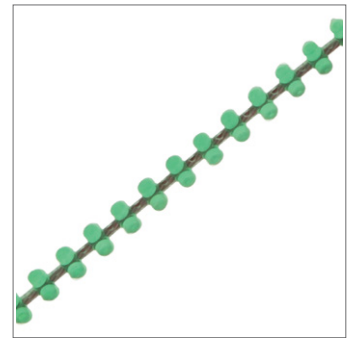
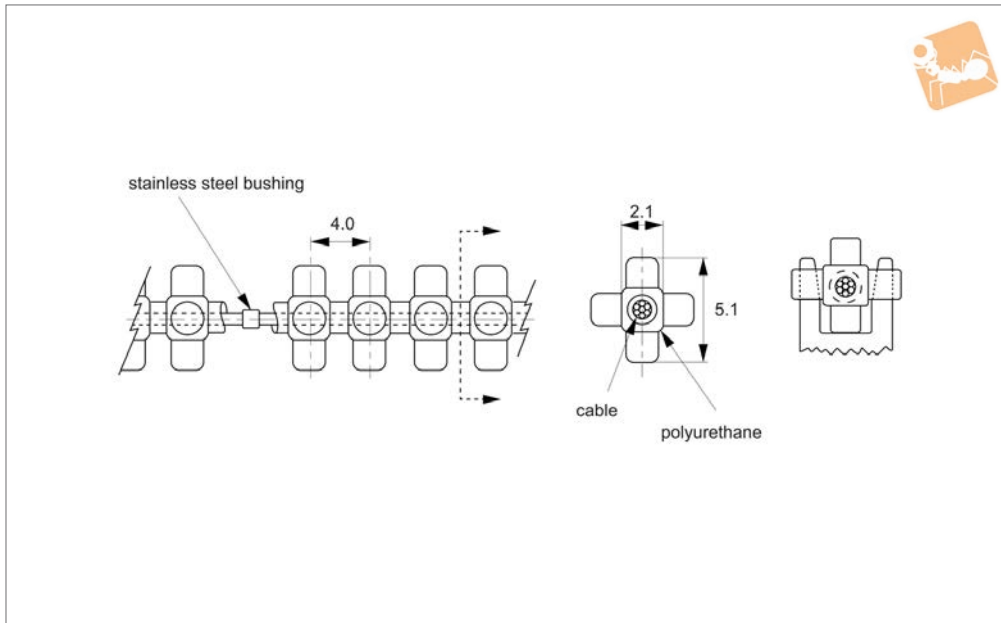

**R1050**

CHAINS, BELTS & PULLEYS

**Material**

0,8mm Ø stainless steel cable encased in polyurethane (green).  
Fibre cable core (aramid) also available (particularly suitable for reverse bend applications)  
when ordering add suffix -EF to order no.

**Technical Notes**

Three dimensional drive, zero backlash, mass 11 grams/metre, silent drive, no

lubrication.

Infinite lengths, 90A Durometer, positive drive.  
Ultimate tensile strength 222N-40N/PIN when belt is used in open loop configuration (without splice, no crimp bushing).  
Temperature range +82°C to -26°C, recommended operating load 53N.  
Recommended max. operating speed 1,91 m/s.

**Tips**

Reduce operating load rating by 50% for self splices  
Self splice kit available R1050.SSK.

**Important Notes**

Operates with R1051, R1052 and R1053 series sprockets.

Order No.	No. of pitches	Length ref.
R1050.030	30	120.0
R1050.035	35	144.0
R1050.040	40	160.0
R1050.045	45	184.0
R1050.050	50	200.0
R1050.055	55	224.0
R1050.060	60	240.0
R1050.070	70	280.0
R1050.080	80	320.0
R1050.090	90	360.0
R1050.100	100	400.0
R1050.110	110	440.0
R1050.120	120	480.0
R1050.130	130	520.0
R1050.140	140	560.0
R1050.150	150	600.0
R1050.160	160	640.0
R1050.170	170	680.0
R1050.180	180	720.0
R1050.190	190	760.0
R1050.200	200	800.0
R1050.210	210	840.0
R1050.220	220	880.0
R1050.230	230	920.0
R1050.240	240	960.0
R1050.250	250	1000.0
R1050.260	260	1040.0

## 3-D Belts

4mm nominal circular pitch



Order No.	No. of pitches	Length ref.
R1050.270	270	1080.0
R1050.280	280	1120.0
R1050.290	290	1160.0
R1050.300	300	1200.0
R1050.310	310	1240.0
R1050.320	320	1280.0
R1050.330	330	1320.0
R1050.340	340	1360.0
R1050.350	350	1400.0
R1050.360	360	1440.0
R1050.400	400	1600.0
R1050.440	440	1760.0
R1050-1.5M	-	1,5 metres not spliced
R1050-3.0M	-	3,0 metres not spliced
R1050-7.5M	-	7,5 metres not spliced
R1050-15M	-	15,0 metres not spliced
R1050-30M	-	30,0 metres not spliced





# Cable Chains

3,747mm circular pitch

# Chains, Belts & Pulleys

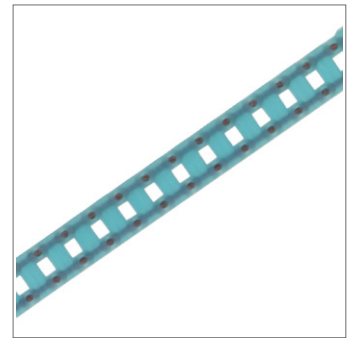
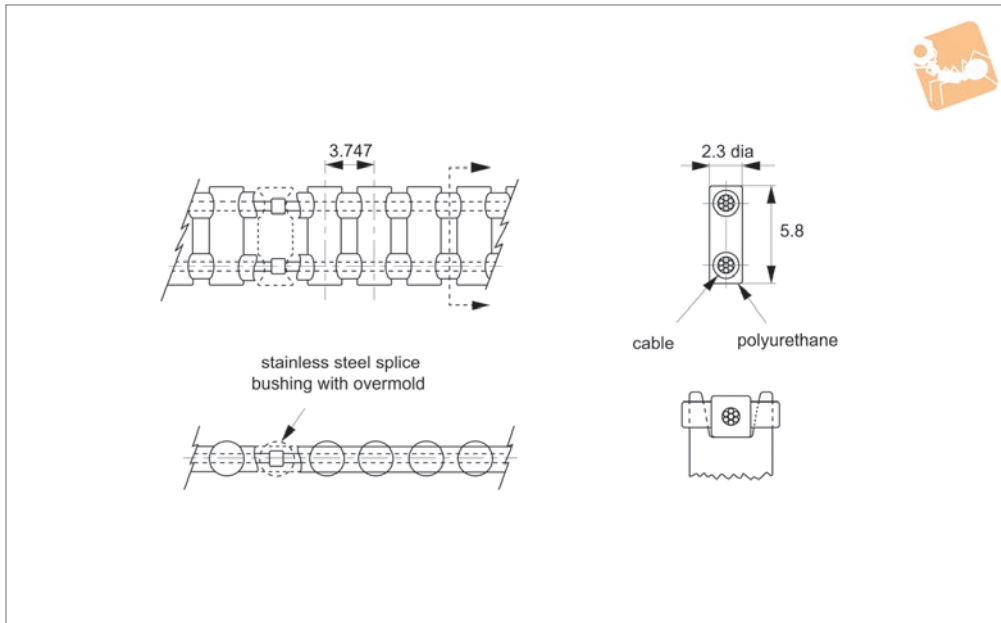

**R1055**

CHAINS, BELTS & PULLEYS

**Material**

Polyurethane (blue) 0,8mm stainless steel cable.

**Technical Notes**

Designed to replace standard metal roller chain systems, no multiple link joints to bind. Lubrication is never required, easily modified to any length, large selection of mating sprockets.

Infinite lengths, silent drive, rust proof, 90A Durometer, non-magnetic, positive drive. Zero backlash, mass 14 grams/metre. Ultimate tensile strength 445N/53PIN when belt is used in open configuration (without splice, no crimp bushing). Temperature range +80°C to -25°C, recommended operating load 111N. Recommended max. operating speed

1,91m/s.

**Tips**

Self splice kit available R1055.SSK. Reduce operating load rating by 50% for self splices.

**Important Notes**

Operates with R1056, R1057 and R1058 series sprockets.

Order No.	No. of pitches	Length
R1055.040	40	149.9
R1055.050	50	187.4
R1055.060	60	224.8
R1055.070	70	262.3
R1055.080	80	299.8
R1055.090	90	337.2
R1055.100	100	374.7
R1055.110	110	412.2
R1055.120	120	449.6
R1055.130	130	487.1
R1055.140	140	524.6
R1055.150	150	562.1
R1055.160	160	599.5
R1055.170	170	637.0
R1055.180	180	674.5
R1055.190	190	711.9
R1055.200	200	749.4
R1055.210	210	786.9
R1055.220	220	824.3
R1055.230	230	861.8
R1055.240	240	899.3
R1055.250	250	936.8
R1055.260	260	974.2
R1055.270	270	1011.7
R1055.280	280	1049.2
R1055.290	290	1086.5
R1055.300	300	1124.1



Order No.	No. of pitches	Length
R1055.310	310	1161.6
R1055.320	320	1199.0
R1055.330	330	1236.5
R1055.340	340	1274.0
R1055.370	370	1386.4
R1055.390	390	1461.3
R1055-1.5M	-	1,5 metres not spliced
R1055-3.0M	-	3,0 metres not spliced
R1055-7.5M	-	7,5 metres not spliced
R1055-15M	-	15,0 metres not spliced
R1055-30M	-	30,0 metres not spliced



# Pin Hub Chain Sprockets, pin hub aluminium, 3,747 circular pitch

Chains, Belts & Pulleys

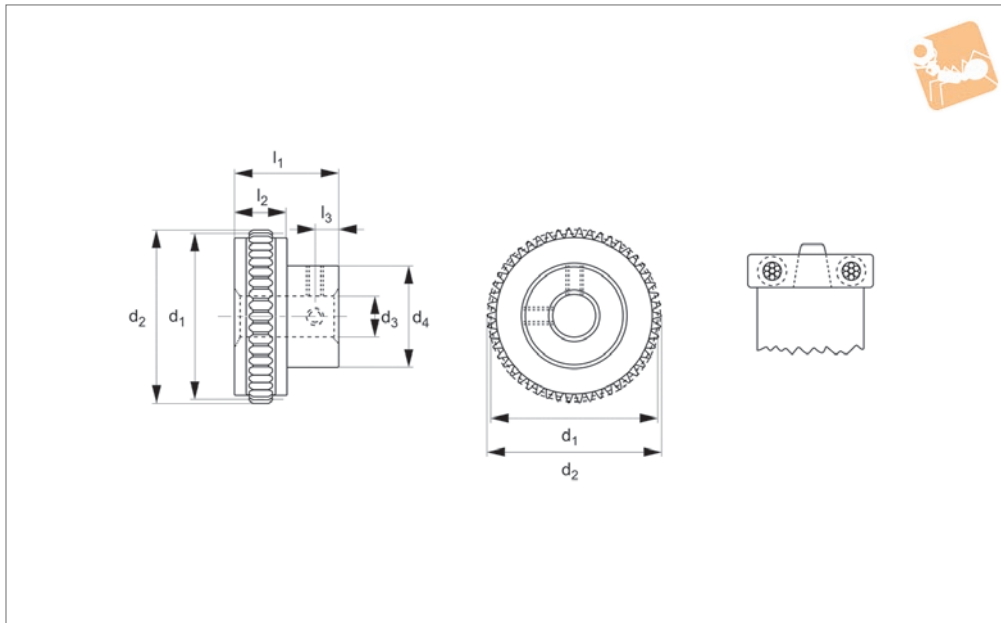

**R1056**

CHAINS, BELTS & PULLEYS

### Material

Aluminium per DIN 3.1355 anodized.

### Technical Notes

<sup>1</sup> For 13-15 teeth, hub diameter equals

13,3.

<sup>2</sup> Sprockets with Ø19,0 PD and smaller are recommended for idler use only.

Other no's of teeth available on request.

### Important Notes

Operate with R1055 series chain.

Order No.	Bore dia.	No. of teeth	Pitch dia.	Outside dia.
R1056.013-04-AL	Ø4	13 <sup>1 2</sup>	15.60	17.63
R1056.014-04-AL	Ø4	14 <sup>1 2</sup>	16.80	18.82
R1056.015-04-AL	Ø4	15 <sup>1 2</sup>	18.00	20.03
R1056.016-04-AL	Ø4	16	19.20	21.23
R1056.018-04-AL	Ø4	18	21.60	23.63
R1056.020-04-AL	Ø4	20	24.00	26.03
R1056.024-04-AL	Ø4	24	28.80	30.83
R1056.025-04-AL	Ø4	25	30.00	32.03
R1056.027-04-AL	Ø4	27	32.40	34.43
R1056.028-04-AL	Ø4	28	33.60	35.63
R1056.029-04-AL	Ø4	29	34.80	36.83
R1056.030-04-AL	Ø4	30	35.99	38.03
R1056.032-04-AL	Ø4	32	38.39	40.43
R1056.034-04-AL	Ø4	34	40.79	42.83
R1056.036-04-AL	Ø4	36	43.19	45.23
R1056.038-04-AL	Ø4	38	45.59	47.63
R1056.040-04-AL	Ø4	40	47.99	50.03
R1056.042-04-AL	Ø4	42	50.39	52.42
R1056.044-04-AL	Ø4	44	52.79	54.82
R1056.048-04-AL	Ø4	48	57.59	59.62
R1056.050-04-AL	Ø4	50	59.99	62.02
R1056.052-04-AL	Ø4	52	62.39	64.42
R1056.054-04-AL	Ø4	54	64.79	66.82
R1056.056-04-AL	Ø4	56	67.19	69.22
R1056.060-04-AL	Ø4	60	71.99	74.02
R1056.065-04-AL	Ø4	65	77.99	80.02
R1056.070-04-AL	Ø4	70	83.99	86.02
R1056.080-04-AL	Ø4	80	95.99	98.02
R1056.013-06-AL	Ø6	13 <sup>1 2</sup>	15.60	17.63
R1056.014-06-AL	Ø6	14 <sup>1 2</sup>	16.80	18.82
R1056.015-06-AL	Ø6	15 <sup>1 2</sup>	18.00	20.03
R1056.016-06-AL	Ø6	16	19.20	21.23
R1056.018-06-AL	Ø6	18	21.60	23.63
R1056.020-06-AL	Ø6	20	24.00	26.03



Order No.	Bore dia.	No. of teeth	Pitch dia.	Outside dia.
R1056.024-06-AL	Ø6	24	28.80	30.83
R1056.025-06-AL	Ø6	25	30.00	32.03
R1056.027-06-AL	Ø6	27	32.40	34.43
R1056.028-06-AL	Ø6	28	33.60	35.63
R1056.029-06-AL	Ø6	29	34.80	36.83
R1056.030-06-AL	Ø6	30	35.99	38.03
R1056.032-06-AL	Ø6	32	38.39	40.43
R1055.034-06-AL	Ø6	34	40.79	42.83
R1056.036-06-AL	Ø6	36	43.19	45.23
R1056.038-06-AL	Ø6	38	45.59	47.63
R1056.040-06-AL	Ø6	40	47.99	50.03
R1056.042-06-AL	Ø6	42	50.39	52.42
R1056.044-06-AL	Ø6	44	52.79	54.82
R1056.013-08-AL	Ø8	13 <sup>1 2</sup>	15.60	17.63
R1056.014-08-AL	Ø8	14 <sup>1 2</sup>	16.80	18.82
R1056.015-08-AL	Ø8	15 <sup>1 2</sup>	18.00	20.03
R1056.016-08-AL	Ø8	16	19.20	21.23
R1056.018-08-AL	Ø8	18	21.60	23.63
R1056.020-08-AL	Ø8	20	24.00	26.03
R1056.024-08-AL	Ø8	24	28.80	30.83
R1056.023-08-AL	Ø8	25	30.00	32.03
R1056.027-08-AL	Ø8	27	32.40	34.43
R1056.028-08-AL	Ø8	28	33.60	35.63
R1056.029-08-AL	Ø8	29	34.80	36.83
R1056.030-08-AL	Ø8	30	35.99	38.03
R1056.032-08-AL	Ø8	32	38.39	40.43
R1056.034-08-AL	Ø8	34	40.79	42.83
R1056.036-08-AL	Ø8	36	43.19	45.23
R1056.038-08-AL	Ø8	38	45.59	47.63
R1056.040-08-AL	Ø8	40	47.99	50.03
R1056.042-08-AL	Ø8	42	50.39	52.42
R1056.044-08-AL	Ø8	44	52.79	54.82
R1056.048-08-AL	Ø8	48	57.59	59.62
R1056.050-08-AL	Ø8	50	59.99	62.02
R1056.052-08-AL	Ø8	52	62.39	64.42
R1056.054-08-AL	Ø8	54	64.79	66.82
R1056.056-08-AL	Ø8	56	67.19	69.22
R1056.060-08-AL	Ø8	60	71.99	74.02
R1056.065-08-AL	Ø8	65	77.99	80.02
R1056.070-08-AL	Ø8	70	83.99	86.02
R1056.080-08-AL	Ø8	80	95.99	98.02
R1056.048-06-AL	Ø6	48	57.59	59.62
R1056.050-06-AL	Ø6	50	59.99	62.02
R1056.052-06-AL	Ø6	52	62.39	64.42
R1056.054-06-AL	Ø6	54	64.79	66.82
R1056.056-06-AL	Ø6	56	67.19	69.22
R1056.060-06-AL	Ø6	60	71.99	74.02
R1056.065-06-AL	Ø6	65	77.99	80.02
R1056.070-06-AL	Ø6	70	83.99	86.02
R1056.080-06-AL	Ø6	80	95.99	98.02



# Chain Sprockets - aluminium, hubless

3,747 circular pitch

## Chains, Belts & Pulleys

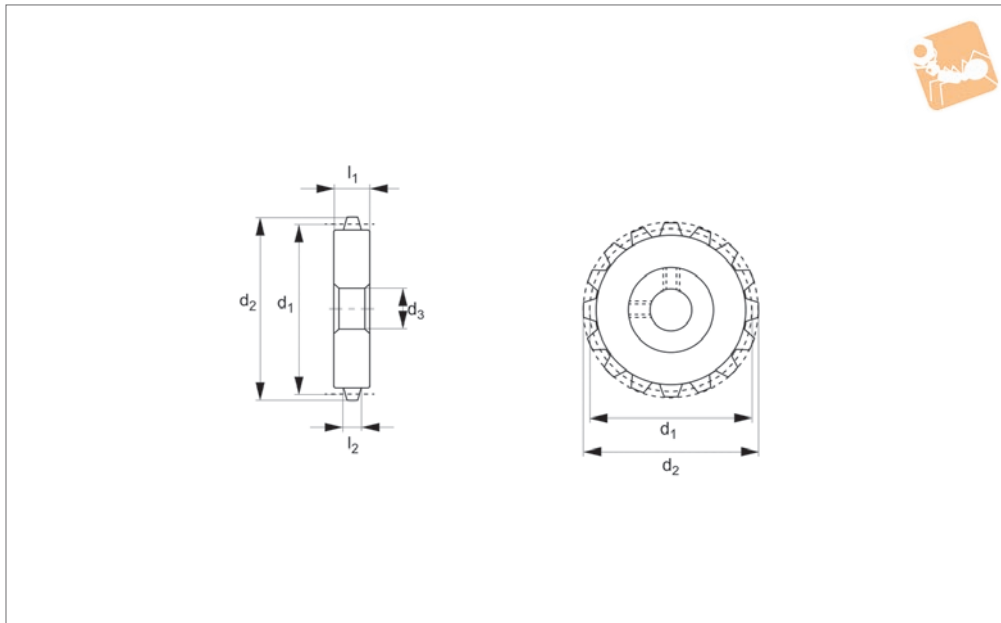

**R1057**

CHAINS, BELTS & PULLEYS

### Material

Aluminium DIN 3,1355 anodized.

recommended for idler use only.

Other no's of teeth available on request.

### Technical Notes

<sup>1</sup>Sprockets with Ø19,0 PD and smaller are

### Important Notes

Operate with R1055 series chain.

Order No.	No. of teeth	Pitch dia.	Outside dia.
R1057.014-HL	14*	16.80	18.82
R1057.015-HL	15*	18.00	20.03
R1057.016-HL	16	19.20	21.23
R1057.018-HL	18	21.60	23.63
R1057.020-HL	20	24.00	26.03
R1057.024-HL	24	28.80	30.83
R1057.025-HL	25	30.00	32.03
R1057.027-HL	27	32.40	34.43
R1057.028-HL	28	33.60	35.63
R1057.029-HL	29	34.80	36.83
R1057.030-HL	30	35.99	38.03
R1057.032-HL	32	38.39	40.43
R1057.034-HL	34	40.79	42.83
R1057.036-HL	36	43.19	45.23
R1057.038-HL	38	45.59	47.63
R1057.040-HL	40	47.99	50.03
R1057.042-HL	42	50.39	52.42
R1057.044-HL	44	52.79	54.82
R1057.048-HL	48	57.59	59.62
R1057.050-HL	50	59.99	62.02
R1057.052-HL	52	62.39	64.42
R1057.054-HL	54	64.79	66.82
R1057.056-HL	56	67.19	69.22
R1057.060-HL	60	71.99	74.02
R1057.065-HL	65	77.99	80.02
R1057.070-HL	70	83.99	86.02
R1057.080-HL	80	95.99	98.02



### R1058

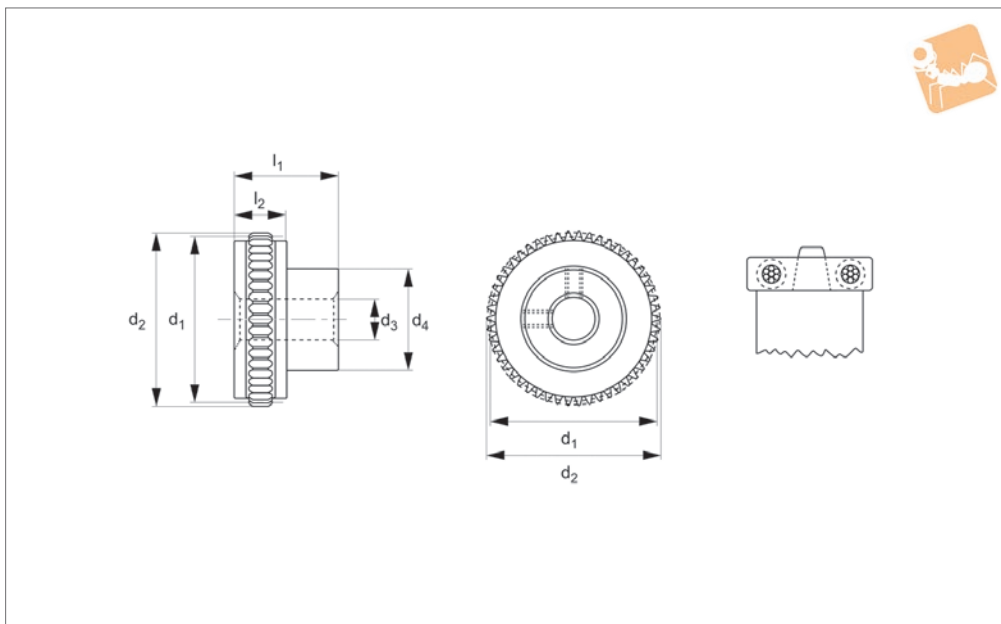

**Material**  
Acetal.

**Technical Notes**  
<sup>1</sup>Teeth runout on hub

<sup>2</sup>Sprockets with Ø19PD and smaller are recommended for idler use only  
Other no's of teeth are available on request.

**Important Notes**  
Operate with R1055 series chain.

Order No.	Bore dia.	No. of teeth	Pitch dia.	Outside dia.
R1058.014-07-AC	Ø7	14 <sup>1 2</sup>	16.80	18.83
R1058.015-07-AC	Ø7	15 <sup>1 2</sup>	18.00	20.03
R1058.016-07-AC	Ø7	16	19.20	21.23
R1058.018-07-AC	Ø7	18	21.60	23.63
R1058.020-07-AC	Ø7	20	24.00	26.03
R1058.022-07-AC	Ø7	22	26.40	28.43
R1058.024-07-AC	Ø7	24	28.80	30.83
R1058.026-07-AC	Ø7	26	31.20	33.23
R1058.030-07-AC	Ø7	30	35.99	38.03
R1058.032-07-AC	Ø7	32	38.39	40.42
R1058.036-07-AC	Ø7	36	43.19	45.23
R1058.040-07-AC	Ø7	40	47.99	50.03
R1058.042-07-AC	Ø7	42	50.39	52.42
R1058.044-07-AC	Ø7	44	52.79	54.83
R1058.045-07-AC	Ø7	45	53.99	56.02
R1058.050-07-AC	Ø7	50	59.99	62.02
R1058.060-07-AC	Ø7	60	71.99	74.02
R1058.014-08-AC	Ø8	14	16.80	18.83
R1058.015-08-AC	Ø8	15	18.00	20.03
R1058.016-08-AC	Ø8	16	19.20	21.23
R1058.018-08-AC	Ø8	18	21.60	23.63
R1058.020-08-AC	Ø8	20	24.00	26.03
R1058.022-08-AC	Ø8	22	26.40	28.43
R1058.024-08-AC	Ø8	24	28.80	30.83
R1058.026-08-AC	Ø8	26	31.20	33.23
R1058.030-08-AC	Ø8	30	35.99	38.03
R1058.032-08-AC	Ø8	32	38.39	40.42
R1058.036-08-AC	Ø8	36	43.19	45.23
R1058.040-08-AC	Ø8	40	47.99	50.03
R1058.042-08-AC	Ø8	42	50.39	52.42
R1058.044-08-AC	Ø8	44	52.79	54.83
R1058.045-08-AC	Ø8	45	53.99	56.02
R1058.050-08-AC	Ø8	50	59.99	62.02
R1058.060-08-AC	Ø8	60	71.99	74.02



# Cable Chains

6,35mm circular pitch

# Chains, Belts & Pulleys

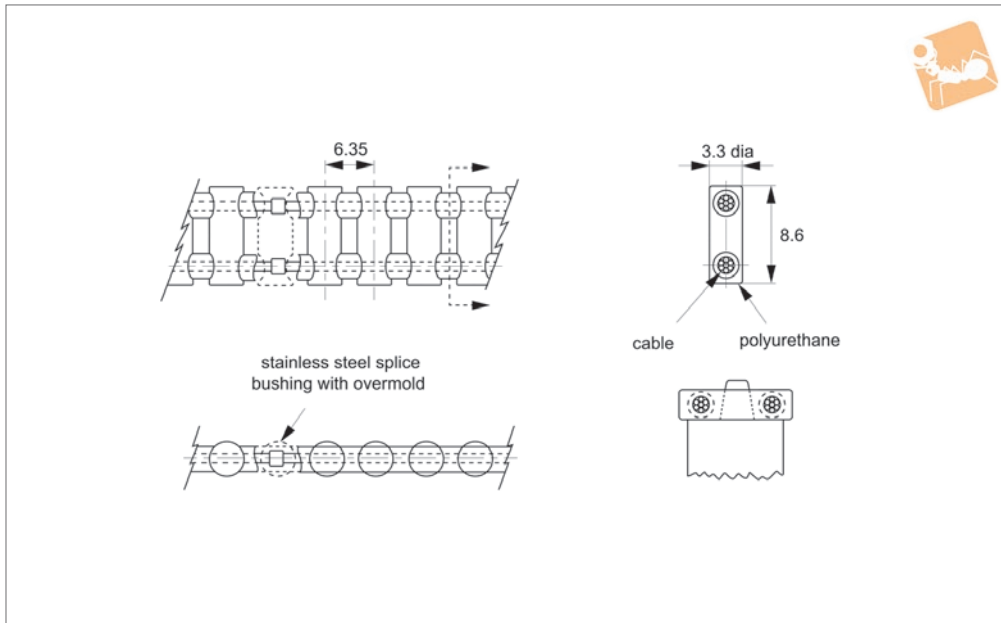

**R1065**

CHAINS, BELTS & PULLEYS

### Material

Polyurethane (yellow) 0,8mm stainless steel cable.

Fibre cable core (aramid) also available (particularly suitable for reverse bend applications).

When ordering aramid core type add suffix -EF to order no.

### Technical Notes

Designed to replace standard metal rolling chain system, no multiple link joints to bind

Easily modified to any length, large selection of mating sprockets, no lubrication  
Infinite lengths, silent drive, rust proof,  
90A Durometer, non-magnetic, positive drive

Zero backlash, mass 28 grams/metre  
Ultimate tensile strength 445N - (22lbs/PIN) when belt is used in open loop configuration (without splice, no crimp bushing)

Temperature range +82°C to -26°C, recommended operating load 111N

Recommended max. operating speed 1,91m/s

Alternate belt construction and reverse belt bending applications available.

### Tips

Self splice kit available R1065.SSK.  
Reduce operating load by 50% for self splices.

### Important Notes

Operates R1066, R1067 and R1068 series sprockets.

Order No.	No. of pitches	Length ref.
R1065.040	40	254.0
R1065.050	50	317.5
R1065.060	60	381.0
R1065.070	70	444.5
R1065.080	80	508.0
R1065.090	90	571.5
R1065.100	100	635.0
R1065.110	110	698.5
R1065.120	120	762.0
R1065.130	130	825.5
R1065.140	140	889.0
R1065.150	150	952.5
R1065.160	160	1016.0
R1065.170	170	1079.5
R1065.180	180	1143.0
R1065.190	190	1206.5
R1065.200	200	1270.0
R1065.210	210	1333.5
R1065.220	220	1397.0
R1065.230	230	1460.5
R1065.240	240	1524.0
R1065.250	250	1587.5
R1065.260	260	1651.0
R1065.270	270	1714.5
R1065.280	280	1778.0



Order No.	No. of pitches	Length ref.
R1065.290	290	1841.5
R1065.300	300	1905.0
R1065.310	310	1968.5
R1065.320	320	2032.0
R1065.330	330	2095.5
R1065.370	370	2349.5
R1065.380	380	2413.0
R1065.390	390	2476.5
R1065-1.5M	-	1,5 metres not spliced
R1065-3.0M	-	3,0 metres not spliced
R1065-7.5M	-	7,5 metres not spliced
R1065-15M	-	15,0 metres not spliced
R1065-30M	-	30,0 metres not spliced





# Cable Chains

9,525mm circular pitch

# Chains, Belts & Pulleys

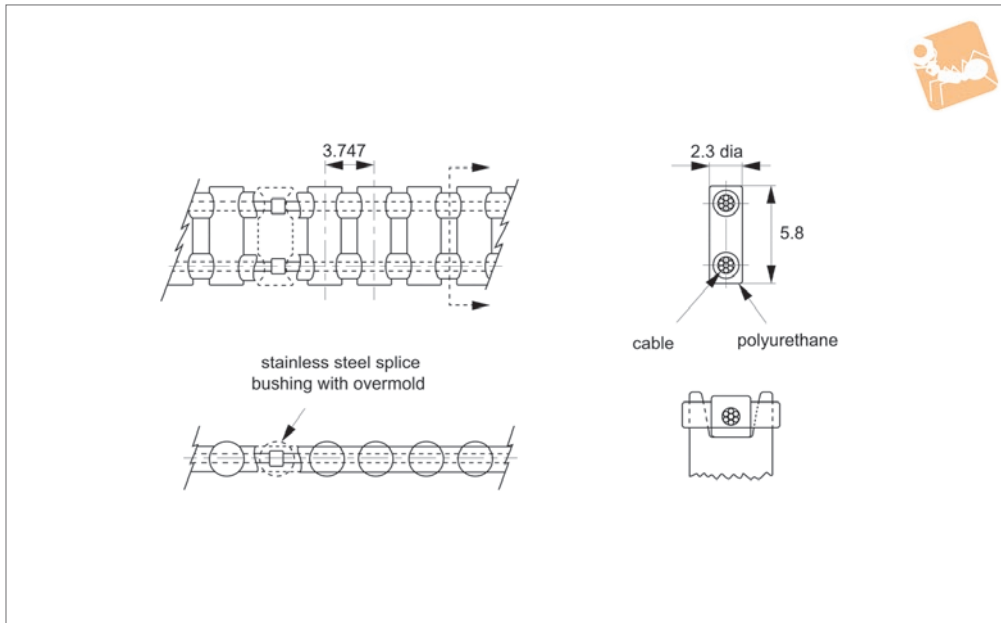

**R1070**

CHAINS, BELTS & PULLEYS

### Material

Polyurethane (brown) 1,2mm stainless steel cable.

Fibre cable core (aramid) also available (particularly suitable for reverse bend applications).

When ordering aramid core type add suffix -EF to order no.

### Technical Notes

Designed to replace standard metal rolling chain system, no multiple link joints to bind.

Lubrication is never required, easily modified to any length, large selection of mating sprockets.

Infinite lengths, silent drive, rust proof, 90A Durometer, non-magnetic, positive drive,

zero backlash, mass 46.5 grams/metre Ultimate tensile strength 890N - (222N/PIN) when belt is used in open loop configuration (without splice, no crimp bushing).

Temperature range +80°C to -25°C, recom-

mended operating load 245N.

Recommended max. operating speed 1,91m/s.

### Tips

Self splice kit available R1070.SSK. Reduce operating load by 50% for self splices.

### Important Notes

Operates R1070 series chain.

Order No.	No. of pitches	Length ref.
R1070.040	40	381.0
R1070.050	50	476.2
R1070.060	60	571.5
R1070.070	70	666.7
R1070.080	80	762.0
R1070.090	90	857.2
R1070.100	100	952.5
R1070.110	110	1047.7
R1070.120	120	1143.0
R1070.130	130	1238.2
R1070.140	140	1333.5
R1070.150	150	1428.7
R1070.160	160	1524.0
R1070.170	170	1617.2
R1070.180	180	1714.5
R1070.190	190	1809.7
R1070.200	200	1905.0
R1070.210	210	2000.2
R1070.220	220	2095.5
R1070.230	230	2190.7
R1070.240	240	2286.0
R1070.250	250	2381.2
R1070.260	260	2476.5
R1070.270	270	2571.7
R1070.280	280	2667.0



Order No.	No. of pitches	Length ref.
R1070.290	290	2762.2
R1070.300	300	2857.5
R1070.310	310	2952.7
R1070.320	320	3048.0
R1070.330	330	3143.2
R1070.370	370	3429.0
R1070.380	380	3524.2
R1070.390	390	3714.7
R1070-1.5M	-	1,5 metres not spliced
R1070-3.0M	-	3,0 metres not spliced
R1070-7.5M	-	7,5 metres not spliced
R1070-15M	-	15,0 metres not spliced
R1070-30M	-	30,0 metres not spliced



# Chain Sprockets - aluminium, pin hub

6,35mm circular pitch

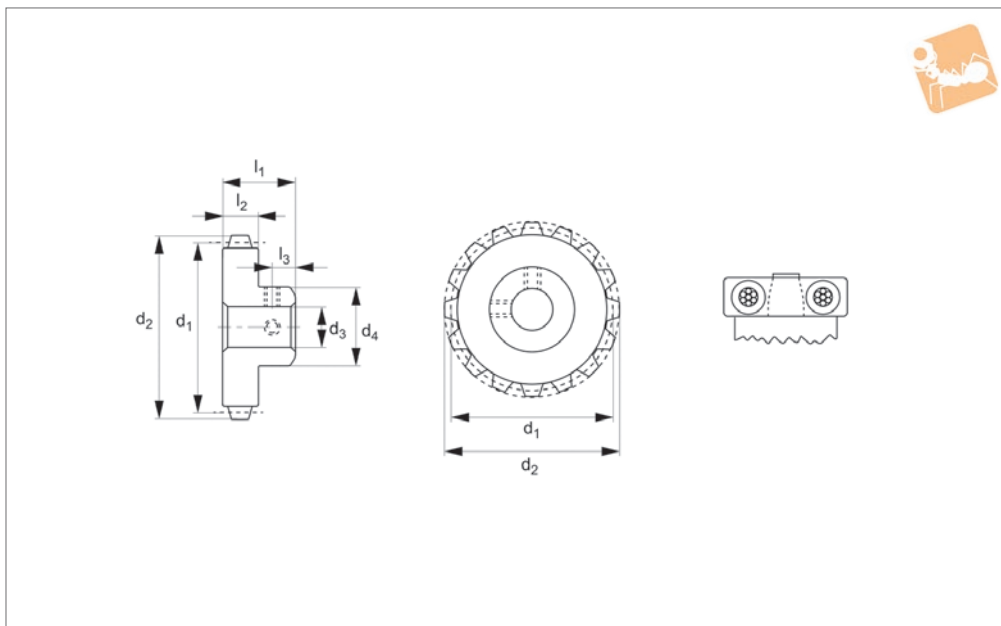

**R1066**

### Material

Aluminum DIN 3,1355 anodized.

### Technical Notes

<sup>1</sup> For 9-10 teeth on 8mmØ bore, hub

diameter equals 14,5.

<sup>1</sup> For 10 teeth on 10mmØ bore and 12mmØ bore, hub diameter equals 16,9.

<sup>2</sup> Sprockets with Ø19PD and smaller are

recommended for idler use only.

Other no's of teeth available on request.

### Important Notes

Operates with R1065 series chain.

Order No.	Bore dia.	No. of teeth	Pitch dia.	Outside dia.
R1066.009-08-AL	Ø8	9 <sup>1 2</sup>	18.19	21.24
R1066.010-08-AL	Ø8	10 <sup>1</sup>	20.21	23.26
R1066.012-08-AL	Ø8	12	24.26	27.30
R1066.013-08-AL	Ø8	13	28.28	29.32
R1066.014-08-AL	Ø8	14	28.30	31.35
R1066.015-08-AL	Ø8	15	30.32	33.37
R1066.016-08-AL	Ø8	16	32.34	35.39
R1066.018-08-AL	Ø8	18	36.38	39.43
R1066.020-08-AL	Ø8	20	40.43	43.47
R1066.024-08-AL	Ø8	24	48.51	51.56
R1066.025-08-AL	Ø8	25	50.53	53.58
R1066.028-08-AL	Ø8	28	56.60	59.64
R1066.030-08-AL	Ø8	30	60.64	63.69
R1066.036-08-AL	Ø8	36	72.77	75.81
R1066.040-08-AL	Ø8	40	80.85	83.90
R1066.048-08-AL	Ø8	48	97.02	100.07
R1066.060-08-AL	Ø8	60	121.28	124.32
R1066.072-08-AL	Ø8	72	145.53	148.58
R1066.009-10-AL	Ø10	9 <sup>1 2</sup>	18.19	21.24
R1066.010-10-AL	Ø10	10 <sup>1</sup>	20.21	23.26
R1066.012-10-AL	Ø10	12	24.26	27.30
R1066.013-10-AL	Ø10	13	28.28	29.32
R1066.014-10-AL	Ø10	14	28.30	31.35
R1066.015-10-AL	Ø10	15	30.32	33.37
R1066.016-10-AL	Ø10	16	32.34	35.39
R1066.018-10-AL	Ø10	18	36.38	39.43
R1066.020-10-AL	Ø10	20	40.43	43.47
R1066.024-10-AL	Ø10	24	48.51	51.56
R1066.025-10-AL	Ø10	25	50.53	53.58
R1066.028-10-AL	Ø10	28	56.60	59.64
R1066.030-10-AL	Ø10	30	60.64	63.69
R1066.036-10-AL	Ø10	36	72.77	75.81
R1066.040-10-AL	Ø10	40	80.85	83.90
R1066.048-10-AL	Ø10	48	97.02	100.07

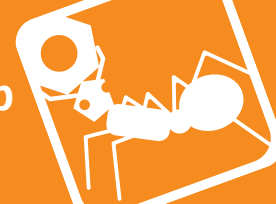

Order No.	Bore dia.	No. of teeth	Pitch dia.	Outside dia.
R1066.060-10-AL	Ø10	60	121.28	124.32
R1066.072-10-AL	Ø10	72	145.53	148.58
R1066.009-12-AL	Ø12	9 <sup>1</sup> 2	18.19	21.24
R1066.010-12-AL	Ø12	10 <sup>1</sup>	20.21	23.26
R1066.012-12-AL	Ø12	12	24.26	27.30
R1066.013-12-AL	Ø12	13	28.28	29.32
R1066.014-12-AL	Ø12	14	28.30	31.35
R1066.015-12-AL	Ø12	15	30.32	33.37
R1066.016-12-AL	Ø12	16	32.34	35.39
R1066.018-12-AL	Ø12	18	36.38	39.43
R1066.020-12-AL	Ø12	20	40.43	43.47
R1066.024-12-AL	Ø12	24	48.51	51.56
R1066.025-12-AL	Ø12	25	50.53	53.58
R1066.028-12-AL	Ø12	28	56.60	59.64
R1066.030-12-AL	Ø12	30	60.64	63.69
R1066.036-12-AL	Ø12	36	72.77	75.81
R1066.040-12-AL	Ø12	40	80.85	83.90
R1066.048-12-AL	Ø12	48	97.02	100.07
R1066.060-12-AL	Ø12	60	121.28	124.32
R1066.072-12-AL	Ø12	72	145.53	148.58



# Hubless Chain Sprockets - hubless aluminium, 6,35mm circular pitch

## Chains, Belts & Pulleys

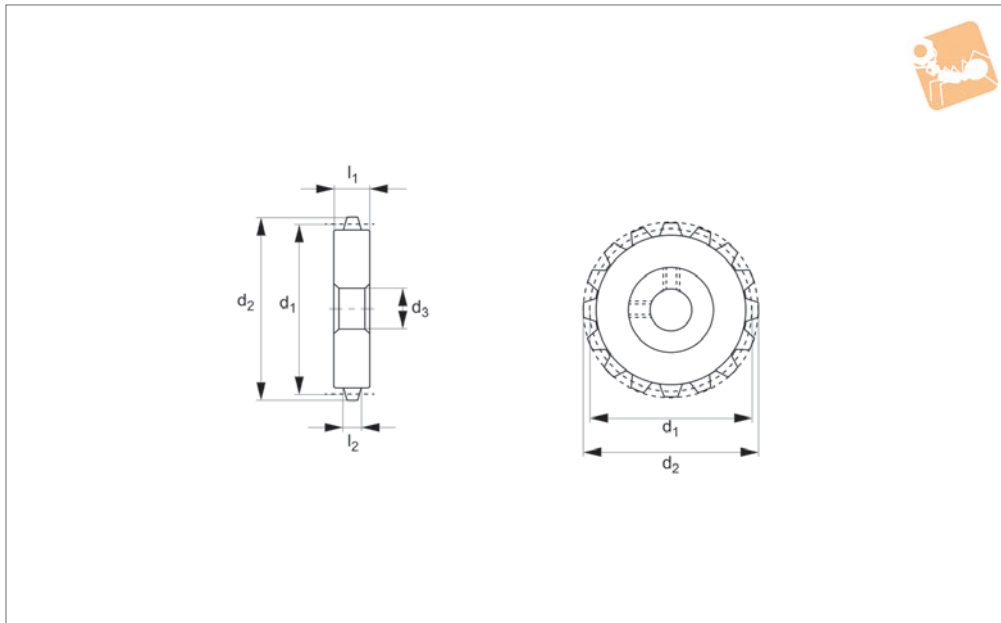

**R1067**

CHAINS, BELTS & PULLEYS

### Material

Aluminium DIN 3,1355 anodized

recommended for idler use only.

Other no's of teeth available on request.

### Technical Notes

<sup>1</sup> Sprockets with Ø19PD and smaller are

### Important Notes

Operates R1065 series chain.

Order No.	No. of teeth	Pitch dia.	Outside dia.
R1067.009-10	9 <sup>1</sup>	18.19	21.24
R1067.010-10	10	20.21	23.26
R1067.012-10	12	24.26	27.30
R1067.013-10	13	28.28	29.32
R1067.014-10	14	28.30	31.35
R1067.015-10	15	30.32	33.37
R1067.016-10	16	32.34	35.39
R1067.018-10	18	36.38	39.43
R1067.020-10	20	40.43	43.47
R1067.024-10	24	48.51	51.56
R1067.025-10	25	50.53	53.58
R1067.028-10	28	56.60	59.64
R1067.030-10	30	60.64	63.69
R1067.036-10	36	72.77	75.81
R1067.040-10	40	80.85	83.90
R1067.048-10	48	97.02	100.07
R1067.060-10	60	121.28	124.32
R1067.072-10	72	145.53	148.58



### R1068

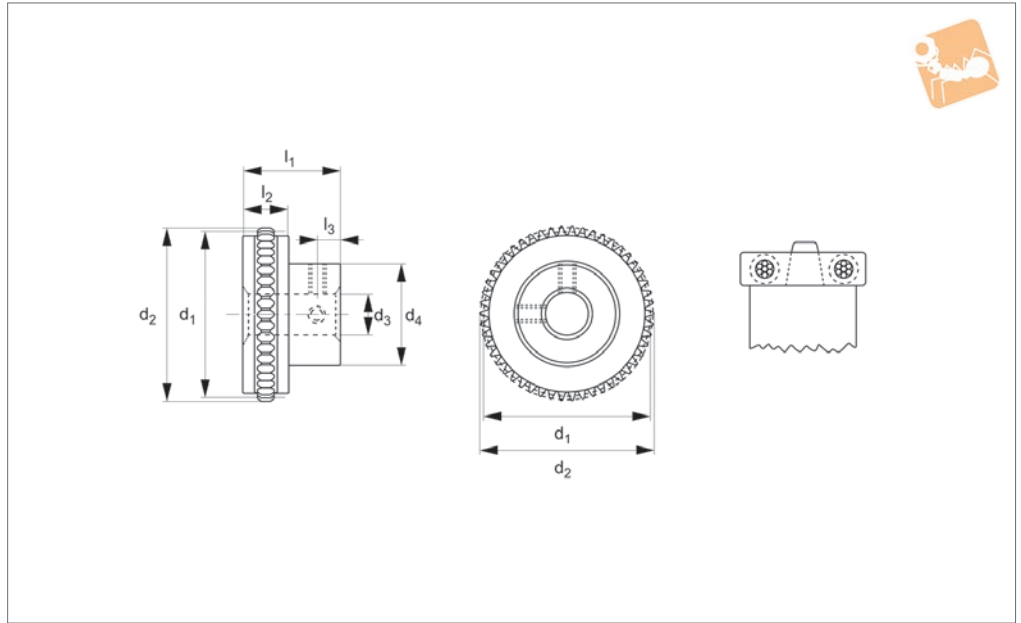

**Material**  
Acetal.

<sup>2</sup> Sprockets with Ø19mm PD and smaller are recommended for idler use only.  
Other no's of teeth are available.

**Important Notes**  
Operates R1065 series chain.

**Technical Notes**

<sup>1</sup> Teeth runout on hub.

Order No.	Bore dia.	No. of teeth	Pitch dia.	Outside dia.
R1068.009-07-AC	Ø7	9 <sup>1 2</sup>	18.19	21.24
R1068.010-07-AC	Ø7	10 <sup>1 2</sup>	20.21	23.26
R1068.012-07-AC	Ø7	12	24.26	27.30
R1068.013-07-AC	Ø7	13	28.28	29.32
R1068.014-07-AC	Ø7	14	28.30	31.35
R1068.015-07-AC	Ø7	15	30.32	33.37
R1068.016-07-AC	Ø7	16	32.34	35.39
R1068.018-07-AC	Ø7	18	36.38	39.43
R1068.020-07-AC	Ø7	20	40.43	43.47
R1068.024-07-AC	Ø7	24	48.51	51.56
R1068.025-07-AC	Ø7	25	50.53	53.58
R1068.028-07-AC	Ø7	28	56.60	59.64
R1068.030-07-AC	Ø7	30	60.64	63.69
R1068.036-07-AC	Ø7	36	72.77	75.81
R1068.009-08-AC	Ø8	9	18.19	21.24
R1068.010-08-AC	Ø8	10	20.21	23.26
R1068.012-08-AC	Ø8	12	24.26	27.30
R1068.013-08-AC	Ø8	13	28.28	29.32
R1068.014-08-AC	Ø8	14	28.30	31.35
R1068.015-08-AC	Ø8	15	30.32	33.37
R1068.016-08-AC	Ø8	16	32.34	35.39
R1068.018-08-AC	Ø8	18	36.38	39.43
R1068.020-08-AC	Ø8	20	40.43	43.47
R1068.024-08-AC	Ø8	24	48.51	51.56
R1068.025-08-AC	Ø8	25	50.53	53.58
R1068.028-08-AC	Ø8	28	56.60	59.64
R1068.030-08-AC	Ø8	30	60.64	63.69
R1068.036-08-AC	Ø8	36	72.77	75.81

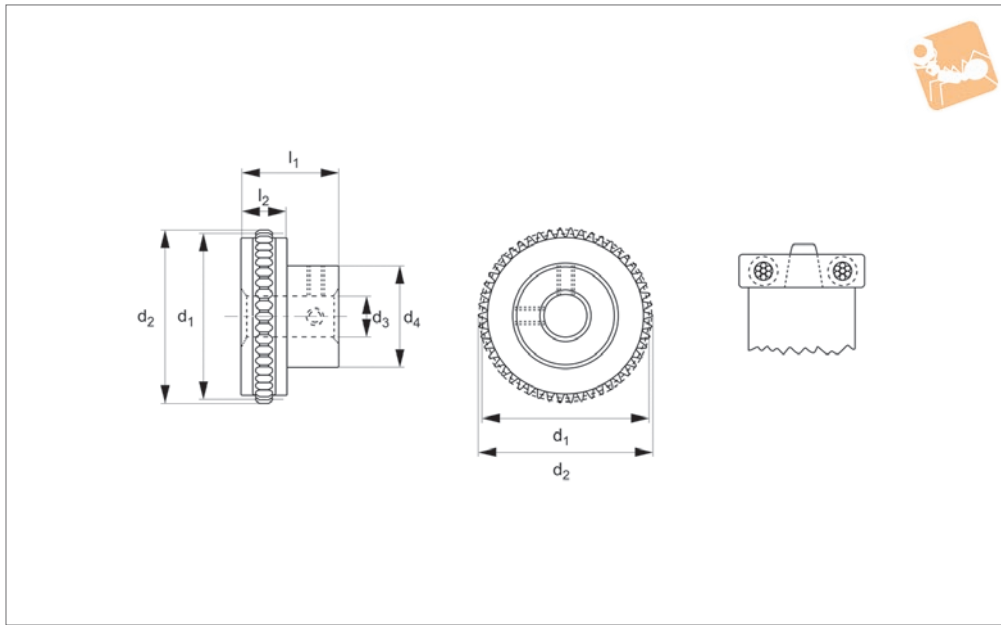

R1071

CHAINS, BELTS & PULLEYS

**Material**

Aluminium DIN 3,1355 anodized.

recommended for idler use only.

Other no's of teeth are available on request.

**Important Notes**

Operate with R1070 series chain.

**Technical Notes**

<sup>1</sup>Sprockets with Ø35mm PD and smaller are

Order No.	Bore dia.	No. of teeth	Pitch dia.	Outside dia.
R1071.008-08-AL	Ø8	8 <sup>1</sup>	24.19	29.27
R1071.015-08-AL	Ø8	15	45.36	50.44
R1071.016-08-AL	Ø8	16	48.39	53.47
R1071.009-08-AL	Ø8	9 <sup>1</sup>	27.22	32.30
R1071.010-08-AL	Ø8	10 <sup>1</sup>	30.24	35.32
R1071.011-08-AL	Ø8	11 <sup>1</sup>	33.27	38.35
R1071.012-08-AL	Ø8	12	36.29	41.37
R1071.018-08-AL	Ø8	18	54.43	59.51
R1071.020-08-AL	Ø8	20	60.48	65.56
R1071.014-08-AL	Ø8	14	42.34	47.42
R1071.024-08-AL	Ø8	24	72.58	77.66
R1071.025-08-AL	Ø8	25	75.60	80.68
R1071.030-08-AL	Ø8	30	90.72	95.80
R1071.032-08-AL	Ø8	32	96.77	101.85
R1071.036-08-AL	Ø8	36	108.87	113.95
R1071.040-08-AL	Ø8	40	120.96	126.04
R1071.048-08-AL	Ø8	48	145.16	150.24
R1071.008-10-AL	Ø10	8 <sup>1</sup>	24.19	29.27
R1071.009-10-AL	Ø10	9 <sup>1</sup>	27.22	32.30
R1071.010-10-AL	Ø10	10 <sup>1</sup>	30.24	35.32
R1071.011-10-AL	Ø10	11 <sup>1</sup>	33.27	38.35
R1071.012-10-AL	Ø10	12	36.29	41.37
R1071.014-10-AL	Ø10	14	42.34	47.42
R1071.015-10-AL	Ø10	15	45.36	50.44
R1071.016-10-AL	Ø10	16	48.39	53.47
R1071.018-10-AL	Ø10	18	54.43	59.51
R1071.020-10-AL	Ø10	20	60.48	65.56
R1071.024-10-AL	Ø10	24	72.58	77.66
R1071.025-10-AL	Ø10	25	75.60	80.68
R1071.030-10-AL	Ø10	30	90.72	95.80
R1071.032-10-AL	Ø10	32	96.77	101.85
R1071.036-10-AL	Ø10	36	108.87	113.95
R1071.040-10-AL	Ø10	40	120.96	126.04
R1071.048-10-AL	Ø10	48	145.16	150.24

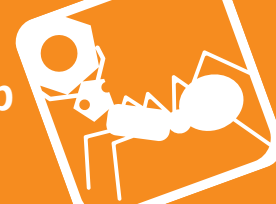

Order No.	Bore dia.	No. of teeth	Pitch dia.	Outside dia.
R1071.008-12-AL	Ø12	8 <sup>1</sup>	24.19	29.27
R1071.009-12-AL	Ø12	9 <sup>1</sup>	27.22	32.30
R1071.010-12-AL	Ø12	10 <sup>1</sup>	30.24	35.32
R1071.011-12-AL	Ø12	11 <sup>1</sup>	33.27	38.35
R1071.012-12-AL	Ø12	12	36.29	41.37
R1071.014-12-AL	Ø12	14	42.34	47.42
R1071.015-12-AL	Ø12	15	45.36	50.44
R1071.016-12-AL	Ø12	16	48.39	53.47
R1071.018-12-AL	Ø12	18	54.43	59.51
R1071.020-12-AL	Ø12	20	60.48	65.56
R1071.024-12-AL	Ø12	24	72.58	77.66
R1071.025-12-AL	Ø12	25	75.60	80.68
R1071.030-12-AL	Ø12	30	90.72	95.80
R1071.032-12-AL	Ø12	32	96.77	101.85
R1071.036-12-AL	Ø12	36	108.87	113.95
R1071.040-12-AL	Ø12	40	120.96	126.04
R1071.048-12-AL	Ø12	48	145.16	150.24





# Chain Sprockets - aluminium, hubless

9,525mm circular pitch

## Chains, Belts & Pulleys

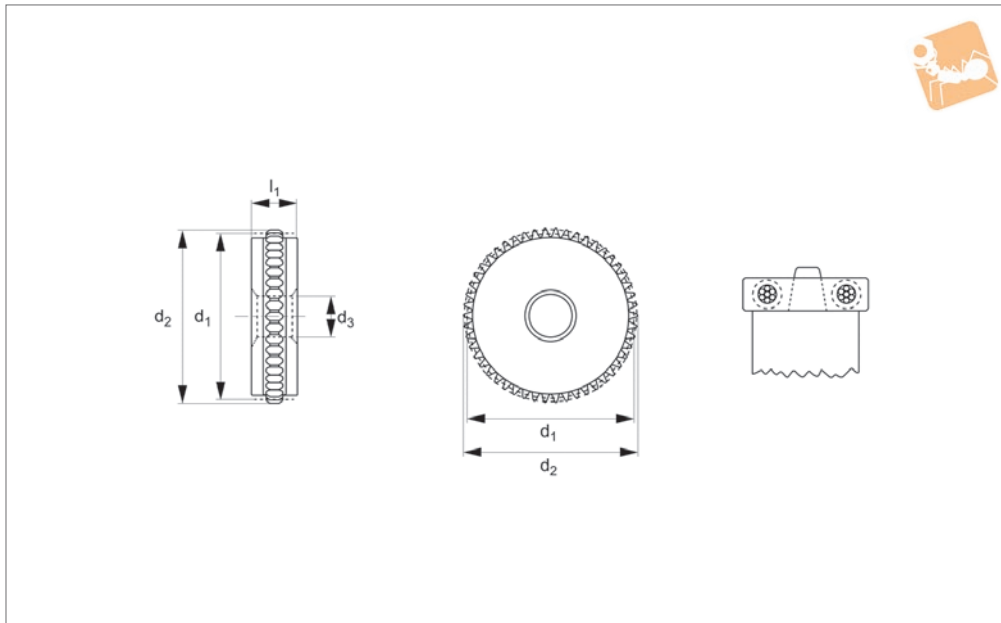

**R1072**

CHAINS, BELTS & PULLEYS

### Material

Aluminium DIN 3,1355 anodized.

recommended for idler use only.

Other no's of teeth are available on request.

### Important Notes

Operate with R1070 series chain.

### Technical Notes

<sup>1</sup>Sprockets with Ø35mm PD and smaller are

Order No.	No. of teeth	Pitch dia.	Outside dia.
R1072.008-10-HL	8 <sup>1</sup>	24.19	29.27
R1072.009-10-HL	9 <sup>1</sup>	27.22	32.30
R1072.010-10-HL	10 <sup>1</sup>	30.24	35.32
R1072.011-10-HL	11 <sup>1</sup>	33.27	38.35
R1072.012-10-HL	12	36.29	41.37
R1072.014-10-HL	14	42.34	47.42
R1072.015-10-HL	15	45.36	50.44
R1072.016-10-HL	16	48.39	53.47
R1072.018-10-HL	18	54.43	59.51
R1072.020-10-HL	20	60.48	65.56
R1072.024-10-HL	24	72.58	77.66
R1072.025-10-HL	25	75.60	80.68
R1072.030-10-HL	30	90.72	95.80
R1072.032-10-HL	32	96.77	101.85
R1072.036-10-HL	36	108.87	113.95
R1072.040-10-HL	40	120.96	126.04
R1072.048-10-HL	48	145.16	150.24

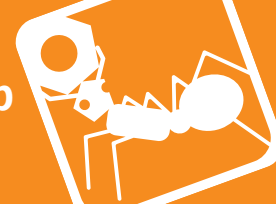

### R1081

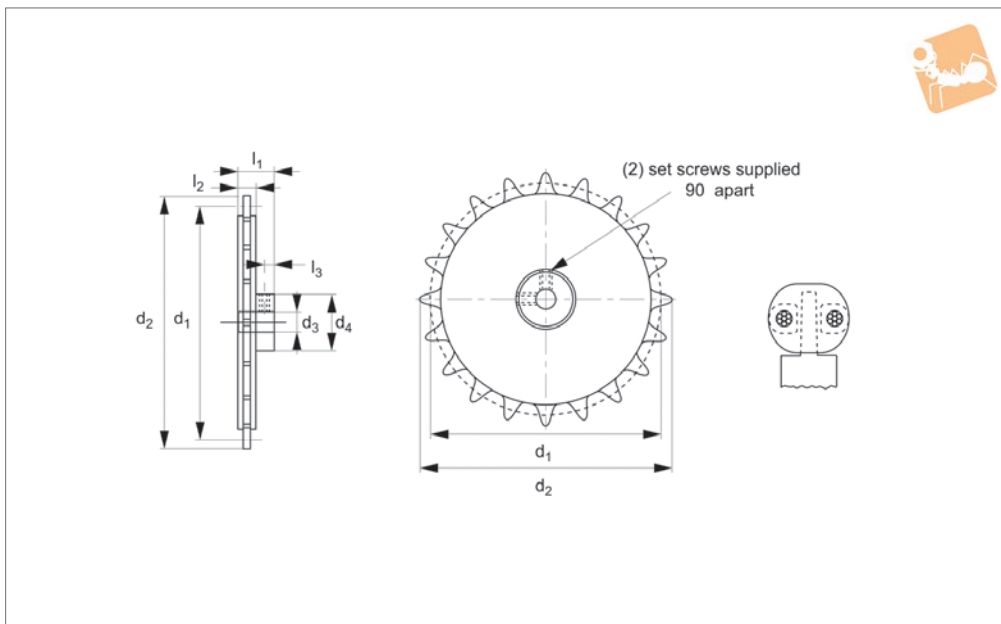

#### Material

Aluminium DIN 3,1355 anodized.

recommended for idler use only.

Other no's of teeth are available on request.

#### Important Notes

Operate with R1080 series chain.

#### Technical Notes

<sup>1</sup>Sprockets with Ø45mm PD and smaller are

Order No.	Bore dia.	No. of teeth	Pitch diameter	Outside dia.
R1081.008-08-AL	Ø8	8 <sup>1</sup>	32.51	38.86
R1081.009-08-AL	Ø8	9 <sup>1</sup>	36.58	42.93
R1081.010-08-AL	Ø8	10 <sup>1</sup>	40.64	46.99
R1081.011-08-AL	Ø8	11 <sup>1</sup>	44.70	51.05
R1081.012-08-AL	Ø8	12	48.77	55.12
R1081.013-08-AL	Ø8	13	52.83	59.18
R1081.014-08-AL	Ø8	14	56.90	63.25
R1081.015-08-AL	Ø8	15	60.96	67.31
R1081.016-08-AL	Ø8	16	65.02	71.37
R1081.018-08-AL	Ø8	18	73.15	79.50
R1081.020-08-AL	Ø8	20	81.28	87.63
R1081.022-08-AL	Ø8	22	89.41	95.76
R1081.024-08-AL	Ø8	24	97.54	103.89
R1081.025-08-AL	Ø8	25	101.60	107.95
R1081.028-08-AL	Ø8	28	113.79	120.14
R1081.030-08-AL	Ø8	30	121.92	128.27
R1081.032-08-AL	Ø8	32	130.05	136.40
R1081.034-08-AL	Ø8	34	138.18	144.53
R1081.036-08-AL	Ø8	36	146.30	152.65
R1081.038-08-AL	Ø8	38	154.43	160.78
R1081.008-10-AL	Ø10	8 <sup>1</sup>	32.51	38.86
R1081.009-10-AL	Ø10	9 <sup>1</sup>	36.58	42.93
R1081.010-10-AL	Ø10	10 <sup>1</sup>	40.64	46.99
R1081.011-10-AL	Ø10	11 <sup>1</sup>	44.70	51.05
R1081.012-10-AL	Ø10	12	48.77	55.12
R1081.013-10-AL	Ø10	13	52.83	59.18
R1081.014-10-AL	Ø10	14	56.90	63.25
R1081.015-10-AL	Ø10	15	60.96	67.31
R1081.016-10-AL	Ø10	16	65.02	71.37
R1081.018-10-AL	Ø10	18	73.15	79.50
R1081.020-10-AL	Ø10	20	81.28	87.63
R1081.022-10-AL	Ø10	22	89.41	95.76
R1081.024-10-AL	Ø10	24	97.54	103.89
R1081.025-10-AL	Ø10	25	101.60	107.95



# Chain Sprockets - aluminium, pin hub

12,7mm nominal circular pitch

## Chains, Belts & Pulleys

Order No.	Bore dia.	No. of teeth	Pitch diameter	Outside dia.
R1081.028-10-AL	Ø10	28	113.79	120.14
R1081.030-10-AL	Ø10	30	121.92	128.27
R1081.032-10-AL	Ø10	32	130.05	136.40
R1081.034-10-AL	Ø10	34	138.18	144.53
R1081.036-10-AL	Ø10	36	146.30	152.65
R1081.038-10-AL	Ø10	38	154.43	160.78
R1081.008-12-AL	Ø12	8 <sup>1</sup>	32.51	38.86
R1081.009-12-AL	Ø12	9 <sup>1</sup>	36.58	42.93
R1081.010-12-AL	Ø12	10 <sup>1</sup>	40.64	46.99
R1081.011-12-AL	Ø12	11 <sup>1</sup>	44.70	51.05
R1081.012-12-AL	Ø12	12	48.77	55.12
R1081.013-12-AL	Ø12	13	52.83	59.18
R1081.014-12-AL	Ø12	14	56.90	63.25
R1081.015-12-AL	Ø12	15	60.96	67.31
R1081.016-12-AL	Ø12	16	65.02	71.37
R1081.018-12-AL	Ø12	18	73.15	79.50
R1081.020-12-AL	Ø12	20	81.28	87.63
R1081.022-12-AL	Ø12	22	89.41	95.76
R1081.024-12-AL	Ø12	24	97.54	103.89
R1081.025-12-AL	Ø12	25	101.60	107.95
R1081.028-12-AL	Ø12	28	113.79	120.14
R1081.030-12-AL	Ø12	30	121.92	128.27
R1081.032-12-AL	Ø12	32	130.05	136.40
R1081.034-12-AL	Ø12	34	138.18	144.53
R1081.036-12-AL	Ø12	36	146.30	152.65
R1081.038-12-AL	Ø12	38	154.43	160.78

CHAINS, BELTS & PULLEYS

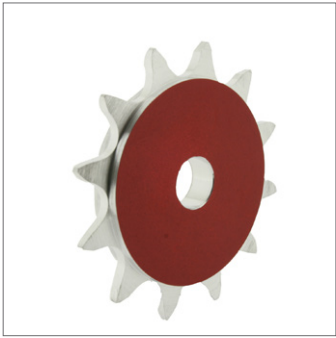

### R1082

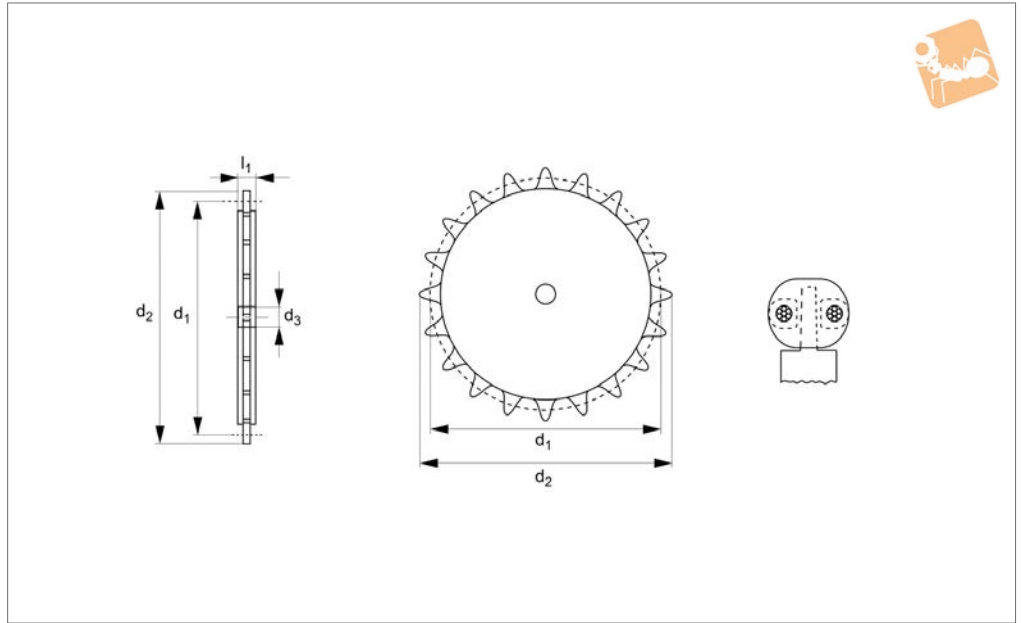

#### Material

Aluminium DIN 3,1355 anodized.

recommended for idler use only.

Other no's of teeth are available on request.

#### Important Notes

Operate with R1080 series chain.

#### Technical Notes

<sup>1</sup> Sprockets with Ø45mm PD and smaller are

Order No.	No. of teeth	Pitch diameter	Outside dia.
R1082.008-HL	8 <sup>1</sup>	32.51	38.86
R1082.009-HL	9 <sup>1</sup>	36.58	42.93
R1082.010-HL	10 <sup>1</sup>	40.64	46.99
R1082.011-HL	11 <sup>1</sup>	44.70	51.05
R1082.012-HL	12	48.77	55.12
R1082.013-HL	13	52.83	59.18
R1082.014-HL	14	56.90	63.25
R1082.015-HL	15	60.96	67.31
R1082.016-HL	16	65.02	71.37
R1082.018-HL	18	73.15	79.50
R1082.020-HL	20	81.28	87.63
R1082.022-HL	22	89.41	95.76
R1082.024-HL	24	97.54	103.89
R1082.025-HL	25	101.60	107.95
R1082.028-HL	28	113.79	120.14
R1082.030-HL	30	121.92	128.27
R1082.032-HL	32	130.05	136.40
R1082.034-HL	34	138.18	144.53
R1082.036-HL	36	146.30	152.65
R1082.038-HL	38	154.43	160.78

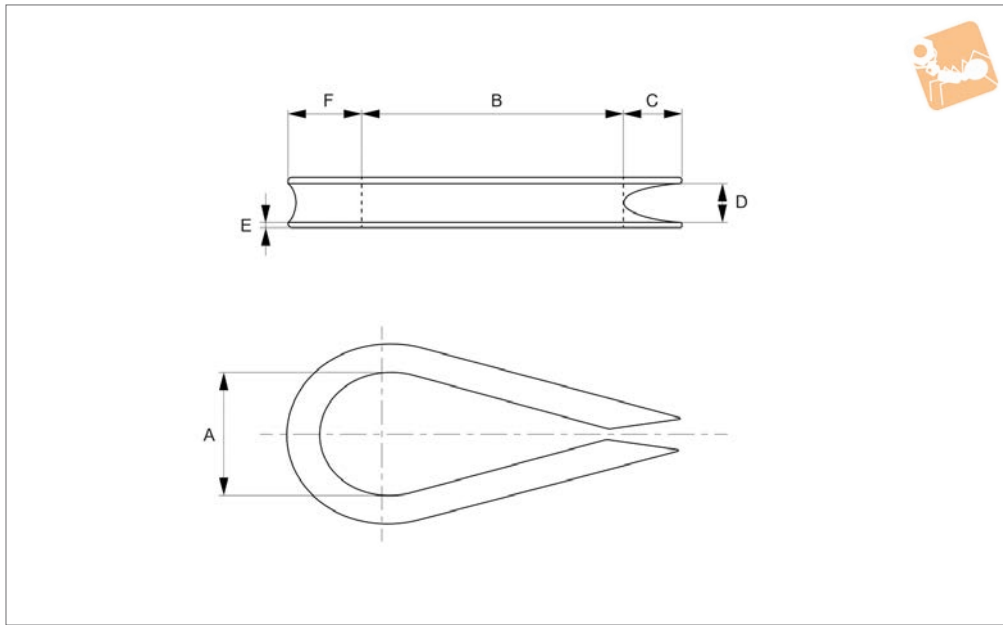

R1098

CHAINS, BELTS & PULLEYS

**Material**  
Stainless steel.

Order No.	Cable dia.	Ø A	b	c	d	e	f
R1098.010	0,4-1,0	4.8	6	3	3	0.4	1
R1098.020	1,0-2,0	9.0	17	5	2	0.8	2
R1098.030	2,4-3,0	9.0	18	6	4	0.8	2
R1098.040	4.0	10.2	20	6	4	0.8	3
R1098.050	5.0	12.7	25	8	5	0.8	4



**R1099**

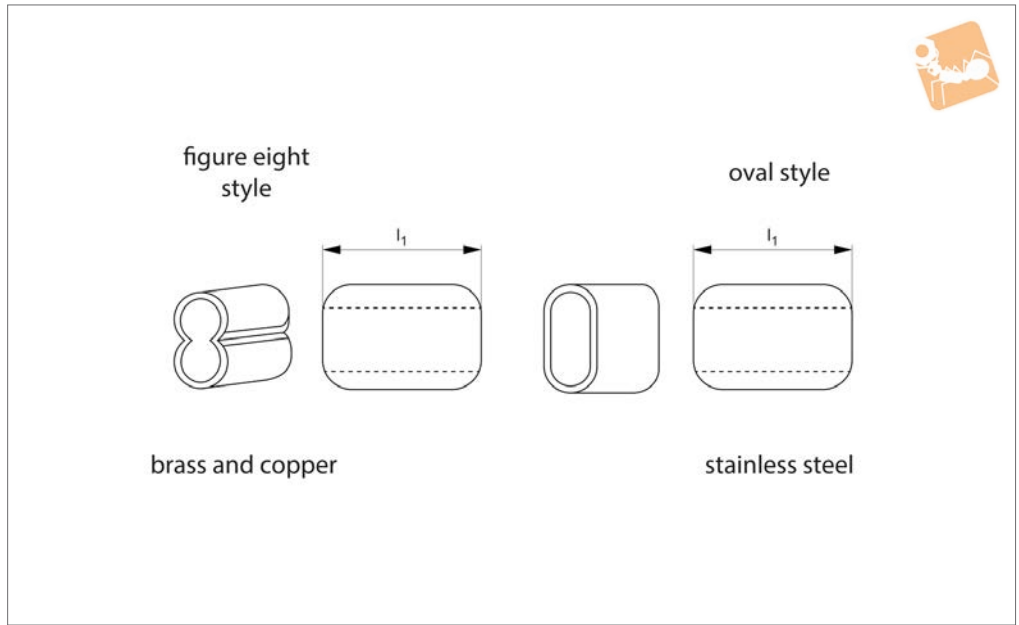

**Material**

Copper (zinc plated), brass or stainless steel.

Order No.	Material	l <sub>1</sub>	Cable dia.	Crimp tool no.
R1099.B04	Brass	6.4	0.4	TL-10
R1099.C08	Copper	7.0	0.8	TL-10
R1099.C10	Copper	11.0	1.0	TL-10
R1099.C16	Copper	6.4	1.6	TL-10
R1099.C20	Copper	12.7	2,0 & 2,4	TL-11
R1099.C30	Copper	19.0	3.0	TL-11
R1099.C40	Copper	22.2	4.0	TL-11
R1099.C50	Copper	31.8	5.0	TL-11
R1099.S04	Stainless	0.8	0.4	TL-4
R1099.S08	Stainless	1.2	0.8	TL-3
R1099.S10	Stainless	3.2	1.0	TL-3
R1099.S16	Stainless	4.8	1.6	TL-7
R1099.S20	Stainless	6.4	2.0	TL-6