



Single Universal Joints

Available with plain bearings or needle roller bearings. Plain bore and keyed bores stocked as standard, hex or square shaped bores on request.

Sizes Bore sizes from 6mm diameter up to 50mm diameter.



Pages 202 - 207

Double Universal Joints

Available with plain bearings or needle roller bearings. Plain bore and keyed bores stocked as standard, hex or square shaped bores on request.

Sizes Bore sizes from 6mm diameter up to 50mm diameter.



Pages 198 - 201

Stainless Steel Universal Joints

Single and double universal joints with plain bearings and plain bores. Keyed, hex, or square shaped bores available on request.

Sizes Bore sizes from 6mm diameter up to 30mm diameter.



Pages 211 - 213

Telescopic Universal Joints

Two universal joints connected by a sliding splined shaft with the ability to extend, allowing adjustments in length during installation.

Sizes Bore sizes from 10mm diameter up to 30mm diameter.



Pages 194 - 197

Universal Joint Bellows

Available for both single and double universal joints, bellows are used to cover and protect the joints.

Sizes Available to protect joints up to 58mm outside diameter.



Pages 208 - 209

Quick Release Universal Joints

Quick change mechanism one end of the joint to allow rapid connection and release of the shaft, ideal when time is critical.

Sizes Bore sizes from 8mm diameter up to 30mm diameter.



Pages 210

ov-universal-joints-overview-rmh- Updated - 29-03-2023

UNIVERSAL JOINTS

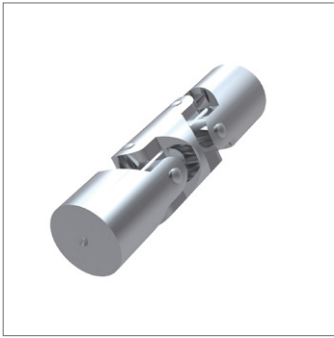

R3683

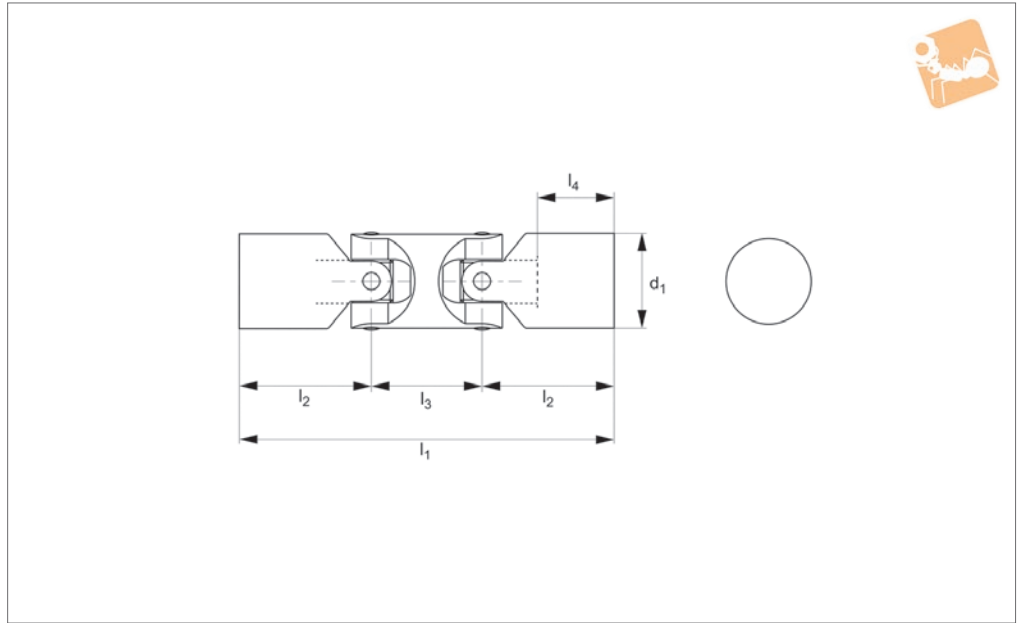

Material

Steel (9SMnPb28k, no. 10718).
Bearing type: Plain bearing.

Maximum bending angle 45° per joint.
Max. drive speed of 1000 rpm.

two shafts offset in relation to each other.
Product variations available on request:
square bores and hex bores.

Technical Notes

To DIN 808.

Tips

Double universal joints are used where large bending angles are required or where

Order No.	Bore dia.	d_1	l_1	l_2	l_3	l_4	Weight g
R3683.013	Unbored	13	61	21	18	14	50
R3683.017	Unbored	17	63	20	22	12	80
R3683.018	Unbored	17	75	26	22	18	80
R3683.020	Unbored	20	89	31	26	21	150
R3683.025	Unbored	25	87	28	30	16	250
R3683.026	Unbored	25	105	37	30	25	350
R3683.032	Unbored	32	125	43	38	26	450
R3683.040	Unbored	40	155	54	46	34	1000
R3683.050	Unbored	50	189	66	56	42	2000
R3683.060	Unbored	60	237	83	70	53	3000

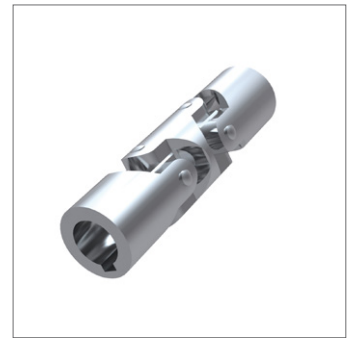
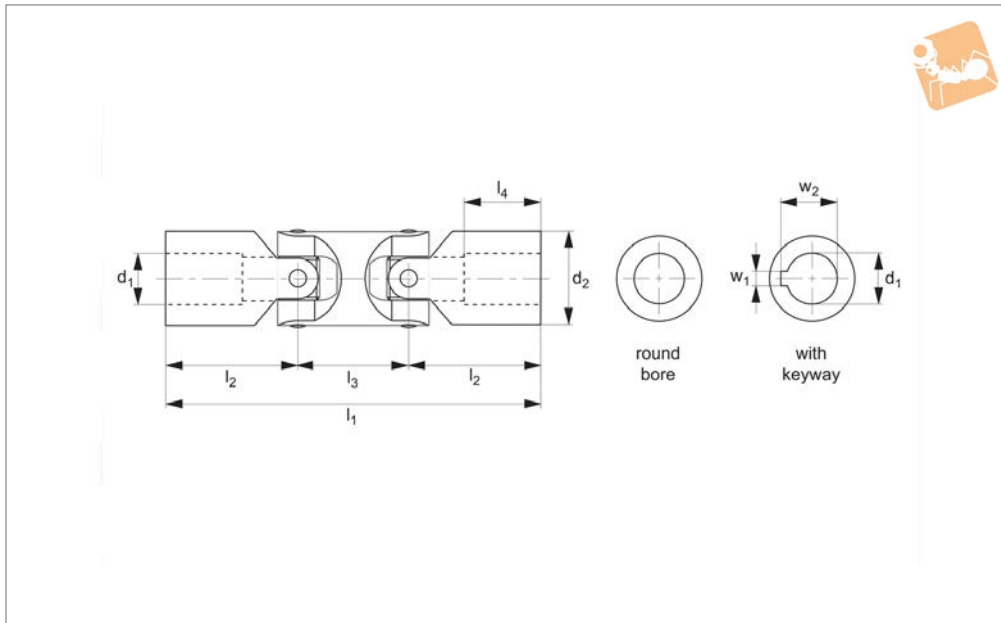

R3684

UNIVERSAL JOINTS

Material

Steel (9 SMnPb28k, no. 10718).
Bearing type: Plain bearing.

Technical Notes

To DIN 808/7551, keyways aligned.

Maximum bending angle 45° per joint.
Max. drive speed of 1000 rpm.

Tips

Double universal joints are used where large bending angles are required or where

two shafts offset in relation to each other. Product variations available on request, for square bores change the suffix to SQ for square bores or HX for hex bores. For stainless steel see R3696.

Order No.	Bore dia.	d ₁ tol. H7	d ₂	l ₁	l ₂	l ₃	l ₄	w ₁ tol. JS9	w ₂	Weight g
R3684.010-RB	Round Bore	10	16	74	26	22	15	-	-	80
R3684.012-RB	Round Bore	12	22	88	31	26	18	-	-	200
R3684.016-RB	Round Bore	16	25	104	37	30	21	-	-	300
R3684.020-RB	Round Bore	20	32	124	43	38	24	-	-	500
R3684.025-RB	Round Bore	25	42	156	54	48	31	-	-	1200
R3684.030-RB	Round Bore	30	50	188	66	56	38	-	-	1700
R3684.040-RB	Round Bore	40	70	238	83	72	47	-	-	4300
R3684.010-KW	With Keyway	10	16	74	26	22	15	3	11.4	80
R3684.012-KW	With Keyway	12	22	88	31	26	18	4	13.8	200
R3684.016-KW	With Keyway	16	25	104	37	30	21	5	18.3	300
R3684.020-KW	With Keyway	20	32	124	43	38	24	6	22.8	500
R3684.025-KW	With Keyway	25	42	156	54	48	31	8	28.3	1200
R3684.030-KW	With Keyway	30	50	188	66	56	38	8	33.3	1700
R3684.040-KW	With Keyway	40	70	238	83	72	47	12	43.3	4300

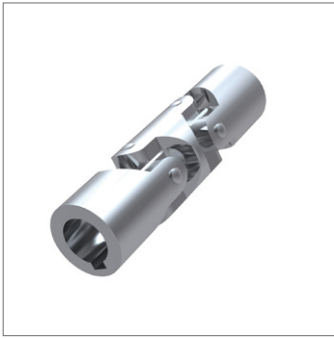

R3685

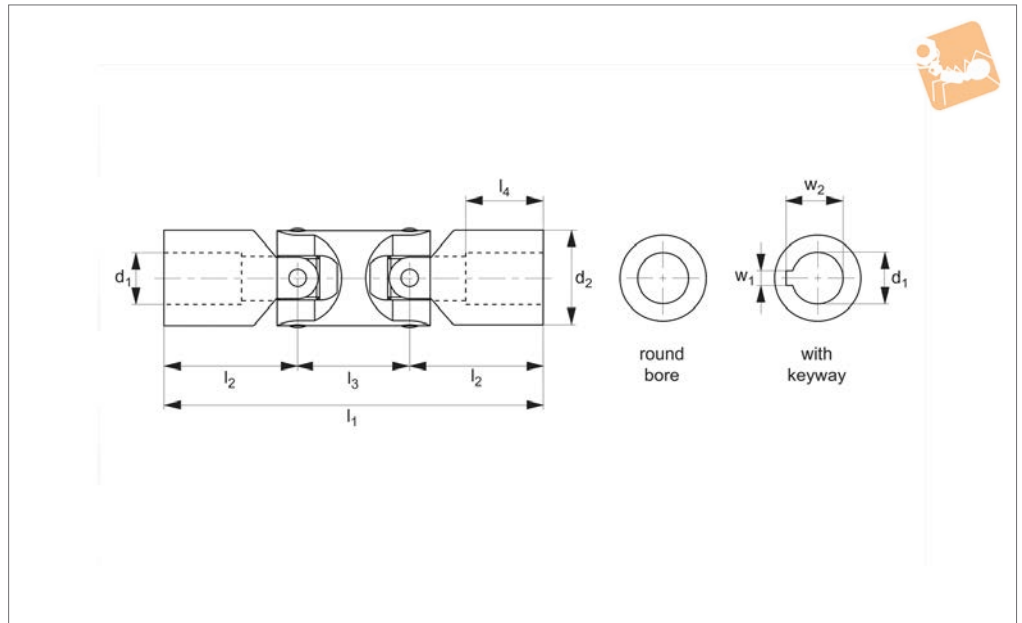

Material

Steel (9SMnPb28k, no. 10718).
Bearing type: Plain bearing.

Technical Notes

To DIN 808, keyways aligned.
Maximum bending angle 45° per joint.

Max. drive speed of 1000 rpm.

Tips

Double universal joints are used where large bending angles are required or where two shafts offset in relation to each other.
Product variations available on request, for

square bores change the suffix to SQ for square bores or HX for hex bores.

For stainless steel see part number R3696, for needle roller bearings see part number R3686.

Order No.	Bore dia.	d ₁ tol. H7	d ₂	l ₁	l ₂	l ₃	l ₄	w ₁ tol. JS9	w ₂	Weight g
R3685.006-RB	Round Bore	6	16	56	17.0	22	8	-	-	80
R3685.008-RB	Round Bore	8	16	62	20.0	22	11	-	-	80
R3685.010-RB	Round Bore	10	22	74	24.0	26	12	-	-	150
R3685.012-RB	Round Bore	12	25	86	28.0	30	13	-	-	250
R3685.014-RB	Round Bore	14	28	96	30.0	36	14	-	-	400
R3685.016-RB	Round Bore	16	32	104	34.0	36	16	-	-	450
R3685.018-RB	Round Bore	18	36	114	37.0	40	17	-	-	700
R3685.020-RB	Round Bore	20	42	128	41.0	46	18	-	-	1000
R3685.022-RB	Round Bore	22	45	145	47.5	50	22	-	-	1550
R3685.025-RB	Round Bore	25	50	163	54.0	55	26	-	-	2000
R3685.030-RB	Round Bore	30	58	190	61.0	68	29	-	-	2900
R3685.032-RB	Round Bore	32	58	198	65.0	68	33	-	-	3000
R3685.035-RB	Round Bore	35	70	212	70.0	72	35	-	-	4750
R3685.040-RB	Round Bore	40	80	245	80.0	85	39	-	-	7200
R3685.050-RB	Round Bore	50	95	290	95.0	100	46	-	-	12.000
R3685.006-KW	With Keyway	6	16	56	17.0	22	8	2	7	80
R3685.008-KW	With Keyway	8	16	62	20.0	22	11	2	9	80
R3685.010-KW	With Keyway	10	22	74	24.0	26	12	3	11.4	150
R3685.012-KW	With Keyway	12	25	86	28.0	30	13	4	13.8	250
R3685.014-KW	With Keyway	14	28	96	30.0	36	14	5	16.3	400
R3685.016-KW	With Keyway	16	32	104	34.0	36	16	5	18.3	450
R3685.018-KW	With Keyway	18	36	114	37.0	40	17	6	20.8	700
R3685.020-KW	With Keyway	20	42	128	41.0	46	18	6	22.8	1000
R3685.022-KW	With Keyway	22	45	145	47.5	50	22	6	24.8	1550
R3685.025-KW	With Keyway	25	50	163	54.0	55	26	8	28.3	2000
R3685.030-KW	With Keyway	30	58	190	61.0	68	29	8	33.3	2900
R3685.032-KW	With Keyway	32	58	198	65.0	68	33	10	35.3	3000
R3685.035-KW	With Keyway	35	70	212	70.0	72	35	10	38.3	4750
R3685.040-KW	With Keyway	40	80	245	80.0	85	39	12	43.3	7200
R3685.050-KW	With Keyway	50	95	290	95.0	100	46	14	53.8	12.000



Double Universal Joint

Needle roller bearings

Universal Joints

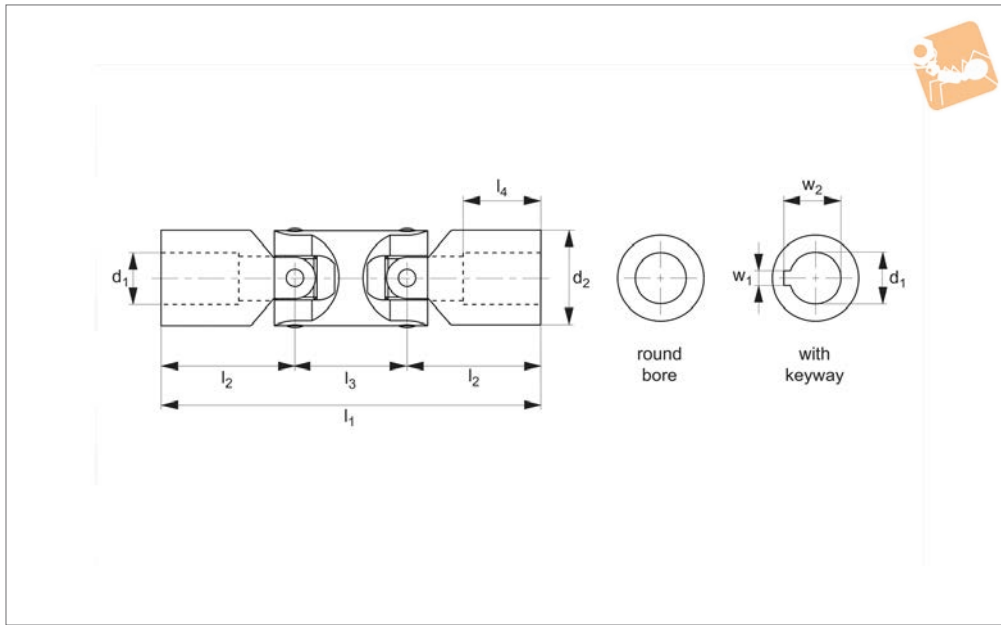

R3686

UNIVERSAL JOINTS

Material

Steel (9SMnPb28k, no. 10718).
Bearing type: needle roller bearing.

Maximum bending angle 45° per joint.
Max. drive speed of 4000 rpm.
Keyways aligned.

Large bending angles are required or where two shafts offset in relation to each other. Product variations available on request, for square bores change the suffix to SQ for square bores or HX for hex bores.

Technical Notes

To DIN 808.

Tips

Double universal joints are used where

Order No.	Bore dia.	d ₁ tol. H7	d ₂	l ₁	l ₂	l ₃	l ₄	w ₁ tol. JS9	w ₂	Weight g
R3686.010-RB	Round bore	10	22	74	24.0	26	12	-	-	150
R3686.012-RB	Round Bore	12	25	86	28.0	30	13	-	-	250
R3686.014-RB	Round Bore	14	28	96	30.0	36	14	-	-	400
R3686.016-RB	Round Bore	16	32	104	34.0	36	16	-	-	450
R3686.018-RB	Round Bore	18	36	114	37.0	40	17	-	-	700
R3686.020-RB	Round Bore	20	42	128	41.0	46	18	-	-	1000
R3686.022-RB	Round Bore	22	45	145	47.5	50	22	-	-	1550
R3686.025-RB	Round Bore	25	50	163	54.0	55	26	-	-	2000
R3686.030-RB	Round Bore	30	58	190	61.0	68	29	-	-	2900
R3686.032-RB	Round Bore	32	58	198	65.0	68	33	-	-	3000
R3686.035-RB	Round Bore	35	70	212	70.0	72	35	-	-	4750
R3686.040-RB	Round Bore	40	80	245	80.0	85	39	-	-	7200
R3686.050-RB	Round Bore	50	95	290	95.0	100	46	-	-	12.000
R3686.010-KW	With keyway	10	22	74	24.0	26	12	3	11.4	150
R3686.012-KW	With Keyway	12	25	86	28.0	30	13	4	13.8	250
R3686.014-KW	With Keyway	14	28	96	30.0	36	14	5	16.3	400
R3686.016-KW	With Keyway	16	32	104	34.0	36	16	5	18.3	450
R3686.018-KW	With Keyway	18	36	114	37.0	40	17	6	20.8	700
R3686.020-KW	With Keyway	20	42	128	41.0	46	18	6	22.8	1000
R3686.022-KW	With Keyway	22	45	145	47.5	50	22	6	24.8	1550
R3686.025-KW	With Keyway	25	50	163	54.0	55	26	8	28.3	2000
R3686.030-KW	With Keyway	30	58	190	61.0	68	29	8	33.3	2900
R3686.032-KW	With Keyway	32	58	198	65.0	68	33	10	35.3	3000
R3686.035-KW	With Keyway	35	70	212	70.0	72	35	10	38.3	4750
R3686.040-KW	With Keyway	40	80	245	80.0	85	39	12	43.3	7200
R3686.050-KW	With Keyway	50	95	290	95.0	100	46	14	53.8	12.000

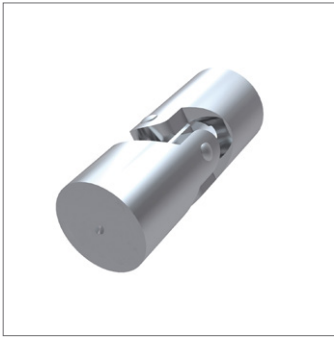

R3687

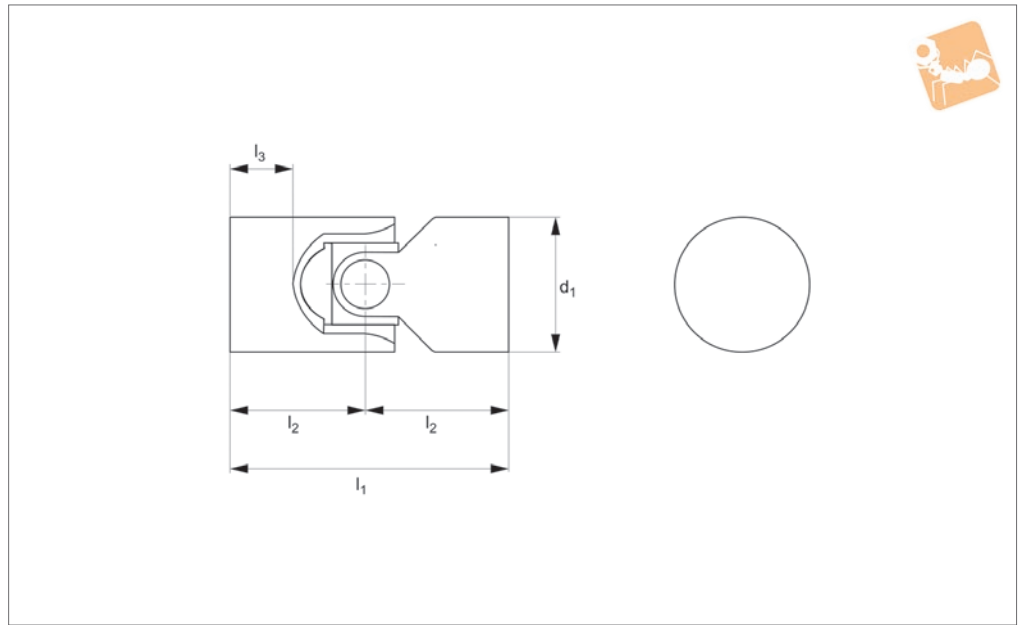

Material

Steel (9SMnPb28k, no. 10718).
Bearing type: Plain bearing.

Technical Notes

To DIN 808.

Maximum bending angle 45° per joint.
Max. drive speed of 1000 rpm.

Tips

Single universal joints are used where shafts off-set towards each other.

Product variations available on request, for square bores change the suffix to SB or HB square bores and hex bores.

Order No.	Bore dia.	d ₁	l ₁	l ₂	d ₁	l ₃	Weight g
R3687.013	Unbored	13	43	21	14	20	
R3687.017	Unbored	17	53	26	18	50	
R3687.020	Unbored	20	63	31	21	70	
R3687.025	Unbored	25	57	28	16	150	
R3687.026	Unbored	25	75	37	25	150	
R3687.032	Unbored	32	87	43	26	290	
R3687.040	Unbored	40	109	54	34	600	
R3687.045	Unbored	45	109	54	34	1120	
R3687.050	Unbored	50	133	66	42	1160	



Single Universal Joint

Steel

Universal Joints

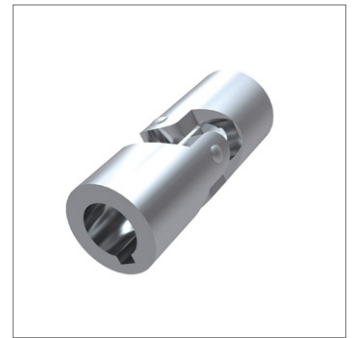
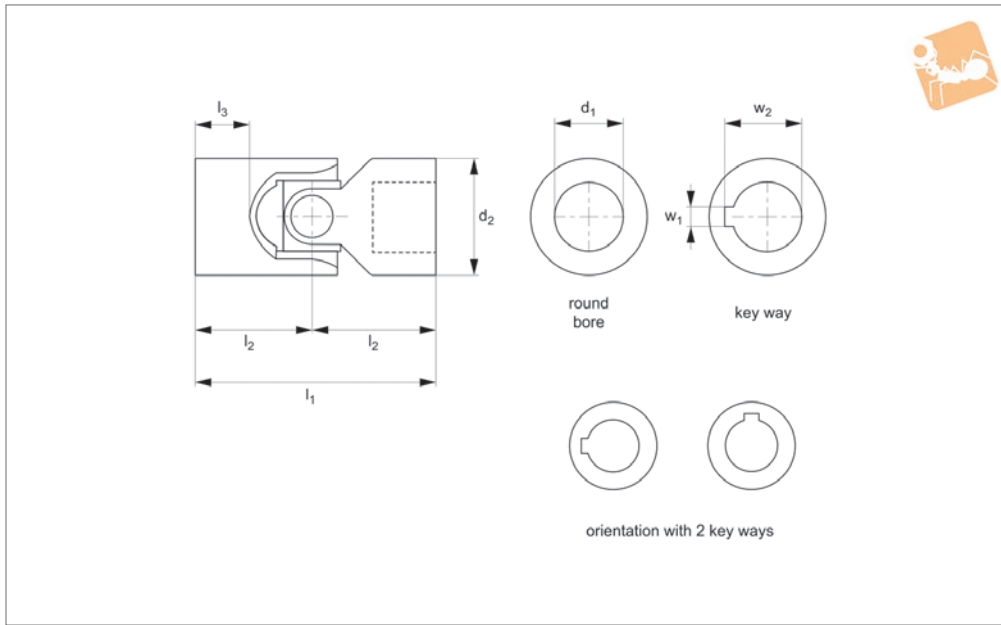

R3688

UNIVERSAL JOINTS

Material

Steel (9SMnPb28k, no. 10718).
Bearing type: plain bearing.

Technical Notes

To DIN 808/7551.
Maximum bending angle 45° per joint,

Max. drive speed of 1000 rpm.

Tips

Single universal joints are used where shafts are off-set towards each other.
Product variations available on request, for square bores change the suffix to SQ for

square bores or HX for hex bores.
For stainless steel see R3694

For needle roller bearings see part number R3690.

Order No.	Bore dia.	d ₁ tol. H7	d ₂	l ₁	l ₂	l ₃	w ₁ tol. JS9	w ₂	Weight g
R3688.010-RB	Round Bore	10	16	52	26	15	-	-	50
R3688.012-RB	Round Bore	12	22	62	31	18	-	-	120
R3688.016-RB	Round Bore	16	25	74	37	21	-	-	200
R3688.020-RB	Round Bore	20	32	86	43	24	-	-	350
R3688.025-RB	Round Bore	25	42	108	54	31	-	-	800
R3688.030-RB	Round Bore	30	50	132	66	38	-	-	1200
R3688.040-RB	Round Bore	40	70	166	83	47	-	-	2900
R3688.010-KW	With Keyway	10	16	52	26	15	3	11.4	50
R3688.012-KW	With Keyway	12	22	62	31	18	4	13.8	120
R3688.016-KW	With Keyway	16	25	74	37	21	5	18.3	200
R3688.020-KW	With Keyway	20	32	86	43	24	6	22.8	350
R3688.025-KW	With Keyway	25	42	108	54	31	8	28.3	800
R3688.030-KW	With Keyway	30	50	132	66	38	8	33.3	1200
R3688.040-KW	With Keyway	40	70	166	83	47	12	43.3	2900

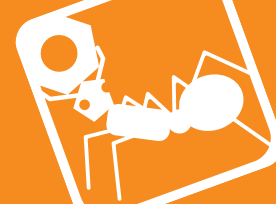

R3689

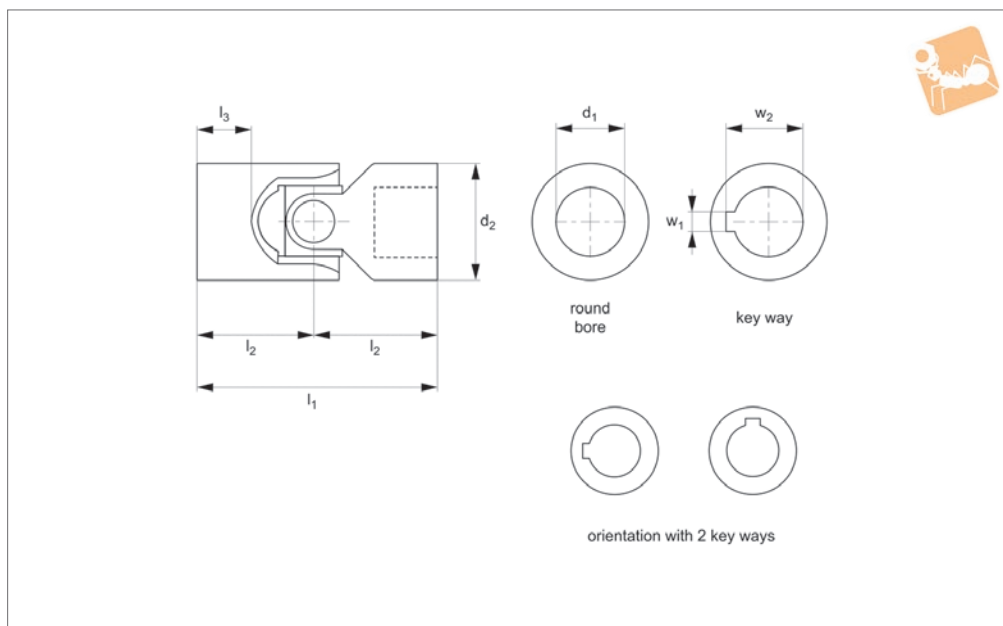

Material

Steel (9SMnPb28k, no. 10718).
Bearing type: plain bearing.

Maximum bending angle 45° per joint.
Max. drive speed of 1000 rpm.

Product variations available on request, for square bores change the suffix to SQ for square bores or HX for hex bores.
For stainless steel see R3694.

Technical Notes

To DIN 808.

Tips

Single universal joints are used where shafts are off-set towards each other.

Order No.	Bore dia.	d ₁ tol. H7	d ₂	l ₁	l ₂	l ₃	w ₁ tol. JS9	w ₂	Weight g
R3689.006-RB	Round Bore	6	16	34	17	8	-	-	50
R3689.008-RB	Round Bore	8	16	40	20	11	-	-	50
R3689.010-RB	Round Bore	10	22	48	24	12	-	-	100
R3689.012-RB	Round Bore	12	25	56	28	13	-	-	160
R3689.014-RB	Round Bore	14	28	60	30	14	-	-	200
R3689.016-RB	Round Bore	16	32	68	34	16	-	-	300
R3689.018-RB	Round Bore	18	36	74	37	17	-	-	450
R3689.020-RB	Round Bore	20	42	82	41	18	-	-	600
R3689.022-RB	Round Bore	22	45	95	47.5	22	-	-	950
R3689.025-RB	Round Bore	25	50	108	54	26	-	-	1200
R3689.030-RB	Round Bore	30	58	122	61	29	-	-	1850
R3689.032-RB	Round Bore	32	58	130	65	33	-	-	2000
R3689.035-RB	Round Bore	35	70	140	70	35	-	-	3150
R3689.040-RB	Round Bore	40	80	160	80	39	-	-	4600
R3689.050-RB	Round Bore	50	95	190	95	46	-	-	7600
R3689.006-KW	With Keyway	6	16	34	17	8	2	7.0	50
R3689.008-KW	With Keyway	8	16	40	20	11	2	9.0	50
R3689.010-KW	With Keyway	10	22	48	24	12	3	11.4	100
R3689.012-KW	With Keyway	12	25	56	28	13	4	13.8	160
R3689.014-KW	With Keyway	14	28	60	30	14	5	16.3	200
R3689.016-KW	With Keyway	16	32	68	34	16	5	18.3	300
R3689.018-KW	With Keyway	18	36	74	37	17	6	20.8	450
R3689.020-KW	With Keyway	20	42	82	41	18	6	22.8	600
R3689.022-KW	With Keyway	22	45	95	47.5	22	6	24.8	950
R3689.025-KW	With Keyway	25	50	108	54	26	8	28.3	1200
R3689.030-KW	With Keyway	30	58	122	61	29	8	33.3	1850
R3689.032-KW	With Keyway	32	58	130	65	33	10	35.3	2000
R3689.035-KW	With Keyway	35	70	140	70	35	10	38.3	3150
R3689.040-KW	With Keyway	40	80	160	80	39	12	43.3	4600
R3689.050-KW	With Keyway	50	95	190	95	46	14	53.8	7600
R3689.006-HB	Hex Bore	6	16	34	17	8	-	-	50
R3689.008-HB	Hex Bore	8	16	40	20	11	-	-	50



Single Universal Joint

Steel

Universal Joints

Order No.	Bore dia.	d ₁ tol. H7	d ₂	l ₁	l ₂	l ₃	w ₁ tol. JS9	w ₂	Weight g
R3689.010-HB	Hex Bore	10	22	48	24	12	-	-	100
R3689.012-HB	Hex Bore	12	25	56	28	13	-	-	160
R3689.014-HB	Hex Bore	14	28	60	30	14	-	-	200
R3689.016-HB	Hex Bore	16	32	68	34	16	-	-	300
R3689.018-HB	Hex Bore	18	36	74	37	17	-	-	450
R3689.020-HB	Hex Bore	20	42	82	41	18	-	-	600
R3689.022-HB	Hex Bore	22	45	95	47.5	22	-	-	950
R3689.025-HB	Hex Bore	25	50	108	54	26	-	-	1200
R3689.030-HB	Hex Bore	30	58	122	61	29	-	-	1850
R3689.032-HB	Hex Bore	32	58	130	65	33	-	-	2000
R3689.035-HB	Hex Bore	35	70	140	70	35	-	-	3150
R3689.040-HB	Hex Bore	40	80	160	80	39	-	-	4600
R3689.050-HB	Hex Bore	50	95	190	95	46	-	-	7600
R3689.006-SB	Square Bore	6	16	34	17	8	-	-	50
R3689.008-SB	Square Bore	8	16	40	20	11	-	-	50
R3689.010-SB	Square Bore	10	22	48	24	12	-	-	100
R3689.012-SB	Square Bore	12	25	56	28	13	-	-	160
R3689.014-SB	Square Bore	14	28	60	30	14	-	-	200
R3689.016-SB	Square Bore	16	32	68	34	16	-	-	300
R3689.018-SB	Square Bore	18	36	74	37	17	-	-	450
R3689.020-SB	Square Bore	20	42	82	41	18	-	-	600
R3689.022-SB	Square Bore	22	45	95	47.5	22	-	-	950
R3689.025-SB	Square Bore	25	50	108	54	26	-	-	1200
R3689.030-SB	Square Bore	30	58	122	61	29	-	-	1850
R3689.032-SB	Square Bore	32	58	130	65	33	-	-	2000
R3689.035-SB	Square Bore	35	70	140	70	35	-	-	3150
R3689.040-SB	Square Bore	40	80	160	80	39	-	-	4600
R3689.050-SB	Square Bore	50	95	190	95	46	-	-	7600

UNIVERSAL JOINTS

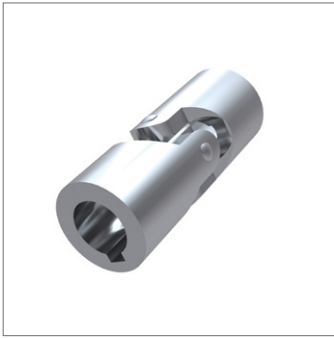

R3690

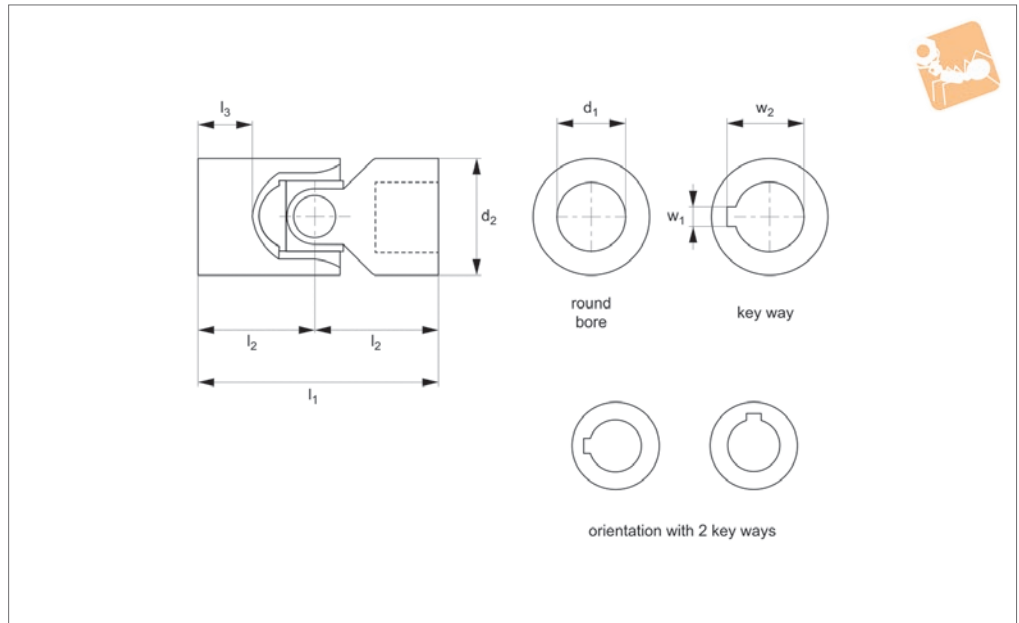

UNIVERSAL JOINTS

Material

Steel (9SMnPb28k, no. 10718).
Bearing type: needle roller bearing.

Technical Notes

To DIN 808.
Maximum bending angle 45° per joint.

Roller bearing lubricated for life.
No maintenance required. Precise, silent and smooth running, Max. drive speed of 4000 rpm.

Tips

Single universal joints are used where

shafts are off-set towards each other.
Product variations available on request, for square bores change the suffix to SQ for square bores or HX for hex bores.

Order No.	Bore dia.	d ₁ tol. H7	d ₂	l ₁	l ₂	l ₃	w ₁ tol. JS9	w ₂	Weight g
R3690.010-RB	Round bore	10	22	48	24	12	-	-	100
R3690.012-RB	Round Bore	12	25	56	28	13	-	-	160
R3690.014-RB	Round Bore	14	28	60	30	14	-	-	200
R3690.016-RB	Round Bore	16	32	68	34	16	-	-	300
R3690.018-RB	Round Bore	18	36	74	37	17	-	-	450
R3690.020-RB	Round Bore	20	42	82	41	18	-	-	600
R3690.022-RB	Round Bore	22	45	95	47.5	22	-	-	950
R3690.025-RB	Round Bore	25	50	108	54	26	-	-	1200
R3690.030-RB	Round Bore	30	58	122	61	29	-	-	1850
R3690.032-RB	Round Bore	32	58	130	65	33	-	-	2000
R3690.035-RB	Round Bore	35	70	140	70	35	-	-	3150
R3690.040-RB	Round Bore	40	80	160	80	39	-	-	4600
R3690.050-RB	Round Bore	50	95	190	95	46	-	-	7600
R3690.010-HB	Hex bore	10	22	48	24	12	-	-	100
R3690.012-HB	Hex bore	12	25	56	28	13	-	-	160
R3690.014-HB	Hex bore	14	28	60	30	14	-	-	200
R3690.016-HB	Hex bore	16	32	68	34	16	-	-	300
R3690.018-HB	Hex bore	18	36	74	37	17	-	-	450
R3690.020-HB	Hex bore	20	42	82	41	18	-	-	600
R3690.022-HB	Hex bore	22	45	95	47.5	22	-	-	950
R3690.025-HB	Hex bore	25	50	108	54	26	-	-	1200
R3690.030-HB	Hex bore	30	58	122	61	29	-	-	1850
R3690.032-HB	Hex bore	32	58	130	65	33	-	-	2000
R3690.035-HB	Hex bore	35	70	140	70	35	-	-	3150
R3690.040-HB	Hex bore	40	80	160	80	39	-	-	4600
R3690.050-HB	Hex bore	50	95	190	95	46	-	-	7600
R3690.010-SB	Square bore	10	22	48	24	12	-	-	100
R3690.012-SB	Square bore	12	25	56	28	13	-	-	160
R3690.014-SB	Square bore	14	28	60	30	14	-	-	200
R3690.016-SB	Square bore	16	32	68	34	16	-	-	300
R3690.018-SB	Square bore	18	36	74	37	17	-	-	450



Single Universal joint

Needle roller bearing

Universal Joints

Order No.	Bore dia.	d ₁ tol. H7	d ₂	l ₁	l ₂	l ₃	w ₁ tol. JS9	w ₂	Weight g
R3690.020-SB	Square bore	20	42	82	41	18	-	-	600
R3690.022-SB	Square bore	22	45	95	47.5	22	-	-	950
R3690.025-SB	Square bore	25	50	108	54	26	-	-	1200
R3690.030-SB	Square bore	30	58	122	61	29	-	-	1850
R3690.032-SB	Square bore	32	58	130	65	33	-	-	2000
R3690.035-SB	Square bore	35	70	140	70	35	-	-	3150
R3690.040-SB	Square bore	40	80	160	80	39	-	-	4600
R3690.050-SB	Square bore	50	95	190	95	46	-	-	7600
R3690.010-KW	With keyway	10	22	48	24	12	3	11.4	100
R3690.012-KW	With Keyway	12	25	56	28	13	4	13.8	160
R3690.014-KW	With Keyway	14	28	60	30	14	5	16.3	200
R3690.016-KW	With Keyway	16	32	68	34	16	5	18.3	300
R3690.018-KW	With Keyway	18	36	74	37	17	6	20.8	450
R3690.020-KW	With Keyway	20	42	82	41	18	6	22.8	600
R3690.022-KW	With Keyway	22	45	95	47.5	22	6	24.8	950
R3690.025-KW	With Keyway	25	50	108	54	26	8	28.3	1200
R3690.030-KW	With Keyway	30	58	122	61	29	8	33.3	1850
R3690.032-KW	With Keyway	32	58	130	65	33	10	35.3	2000
R3690.035-KW	With Keyway	35	70	140	70	35	10	38.3	3150
R3690.040-KW	With Keyway	40	80	160	80	39	12	43.3	4600
R3690.050-KW	With Keyway	50	95	190	95	46	14	53.8	7600

UNIVERSAL JOINTS



R3691

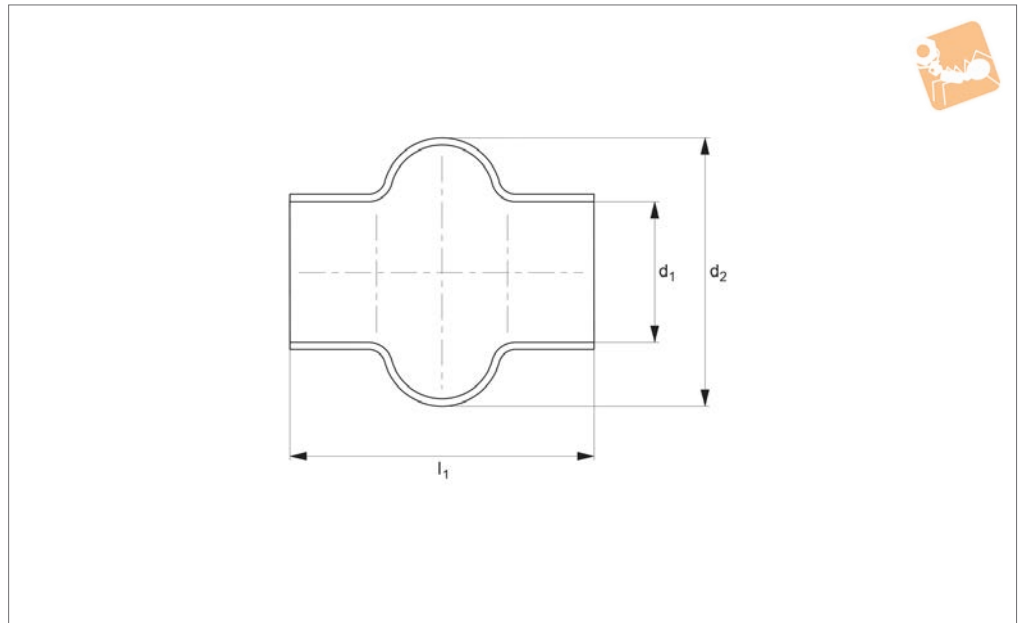

Material
Rubber.

Tips
Bellows give universal joints full protec-

tion against ingress of dirt.
They can be filled with grease which gives
long term lubrication for friction bearings.
Bellows should be secured at each end with

two cable ties (not supplied).

Order No.	To suit joint of o.d	d ₁	d ₂	l ₁
R3691.016	16	15.0	28	34
R3691.018	18	16.5	32	40
R3691.022	22	20.5	40	45
R3691.025	25/26	24.5	48	50
R3691.028	28/29	27.5	52	56
R3691.032	32	30.5	56	65
R3691.036	36/37	35.5	66	72
R3691.042	42	40.0	75	82
R3691.045	45/47	45.0	84	95
R3691.050	50/52	50.0	92	108
R3691.058	58	56.0	100	122



Bellows

for double universal joints

Universal Joints

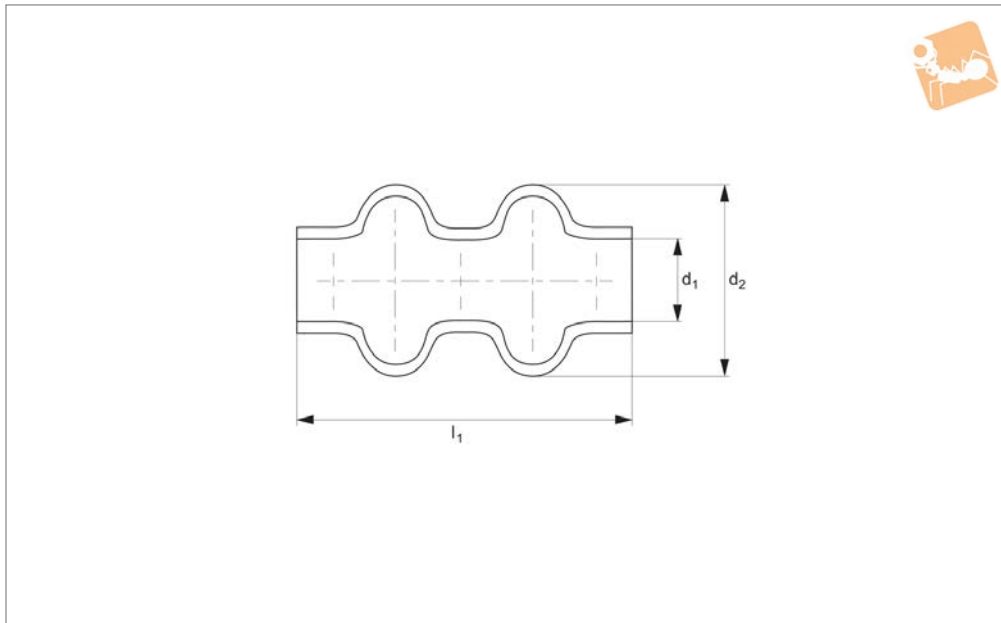

R3692

UNIVERSAL JOINTS

Material

Black elastomer plastic (smooth PVC)

Tips

Bellows give universal joints full protec-

tion against ingress of dirt.

They can be filled with grease which gives long term lubrication for friction bearings. Bellows should be secured at each end with two cable ties (not supplied).

Order No.	To suit joint of o.d	d ₁	d ₂	l ₁
R3692.016	16	16	35	55
R3692.022	22	20	36	65
R3692.025	25	24	44	70
R3692.028	28	28	51	80
R3692.032	32	32	62	90
R3692.042	42	40	73	120
R3692.050	50	50	90	155



R3693

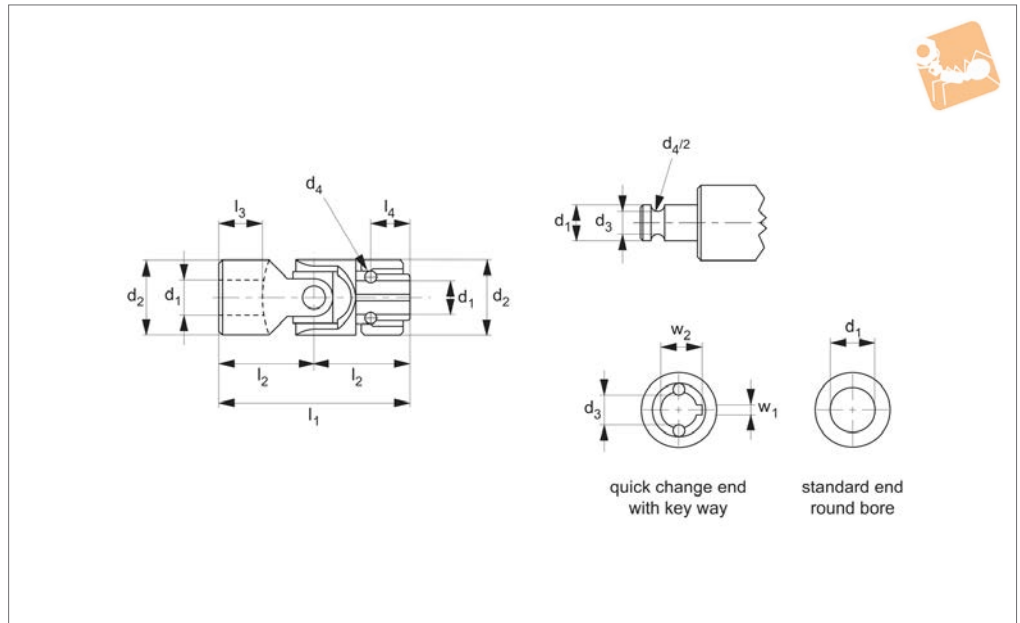

Material

Steel (9 SMnPb28 k, no. 10718, greased).
Bearing type: plain bearing.

Technical Notes

To DIN 808.
Maximum bending angle 45° per joint.
Max. drive speed of joints with journal

bearings 1000 rpm.

Tips

Rapid change coupling ideal where time is critical.
Retention of shaft accomplished with two ball bearings engaging the shaft via a round bore with keyway.

Product variations available on request: needle bearings and hex shaped bores. (Keyway and hex shaped bores on quick change end only unless requested otherwise.)

Order No.	d ₁ tol. H7	d ₂	d ₃	d ₄	l ₁	l ₂	l ₃	l ₄	w ₁ tol. JS9	w ₂	Weight g
R3693.010	10	22	8.7	4	62	31	17	11.5	3	11	100
R3693.012	12	25	11	4	74	37	21	13.5	4	13.3	160
R3693.014	14	25	13	4	74	37	21	13.5	5	15.3	160
R3693.016	16	32	14.8	6.35	86	43	24	14	5	17.3	310
R3693.018	18	36	16	8	96	48	28	19	6	19.8	460
R3693.020	20	42	18	8	108	54	31	19	6	22.8	610
R3693.022	22	45	20	10	120	60	34	20.5	6	24.8	960
R3693.025	25	50	23	10	132	66	38	20.5	8	28.3	1150
R3693.030	30	58	28	10	166	83	49	25	8	33.3	2080



Stainless Single Universal Joint

Stainless

Universal Joints

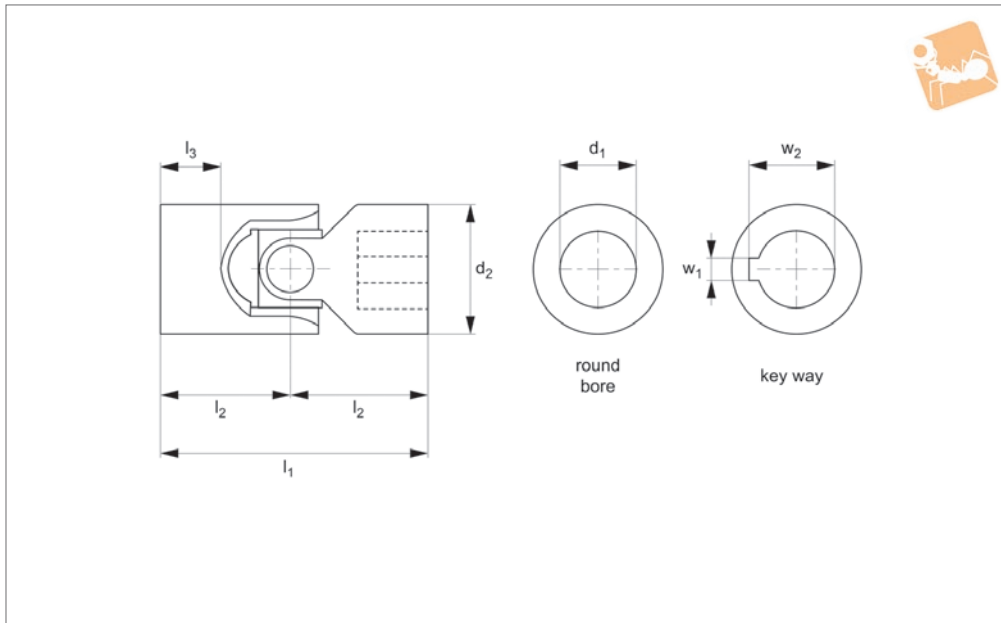

R3694

UNIVERSAL JOINTS

Material

Stainless steel (AISI 304)

Technical Notes

To DIN 808, maximum bending angle 45° per joint.

Tips

Single universal joints are used where shafts are off-set towards each other.

Product variations available on request, for square bores change the suffix to SQ for square bores or HX for hex bores.

Order No.	Bore dia.	d ₁ tol. H7	d ₂	l ₁	l ₂	l ₃	w ₁ tol. JS9	w ₂	Weight g
R3694.006-RB	Round Bore	6	16	34	17	8	-	-	50
R3694.008-RB	Round Bore	8	16	40	20	11	-	-	50
R3694.010-RB	Round Bore	10	22	48	24	12	-	-	100
R3694.012-RB	Round Bore	12	25	56	28	13	-	-	160
R3694.016-RB	Round Bore	16	32	68	34	16	-	-	300
R3694.020-RB	Round Bore	20	42	82	41	18	-	-	600
R3694.025-RB	Round Bore	25	50	108	54	26	-	-	1200
R3694.030-RB	Round Bore	30	58	122	61	29	-	-	1850
R3694.006-KW	Keyway	6	16	34	17	8	2	7.0	50
R3694.008-KW	Keyway	8	16	40	20	11	2	9.0	50
R3694.010-KW	Keyway	10	22	48	24	12	3	11.4	100
R3694.012-KW	Keyway	12	25	56	28	13	4	13.8	160
R3694.016-KW	Keyway	16	32	68	34	16	5	18.3	300
R3694.020-KW	Keyway	20	42	82	41	18	6	22.8	600
R3694.025-KW	Keyway	25	50	108	54	26	8	28.3	1200
R3694.030-KW	Keyway	30	58	122	61	29	8	33.3	1850

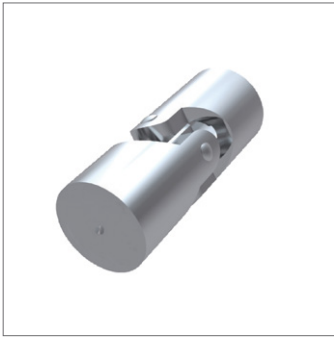
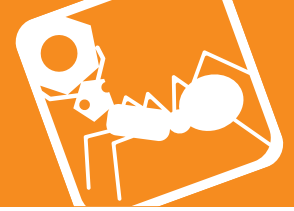

R3695

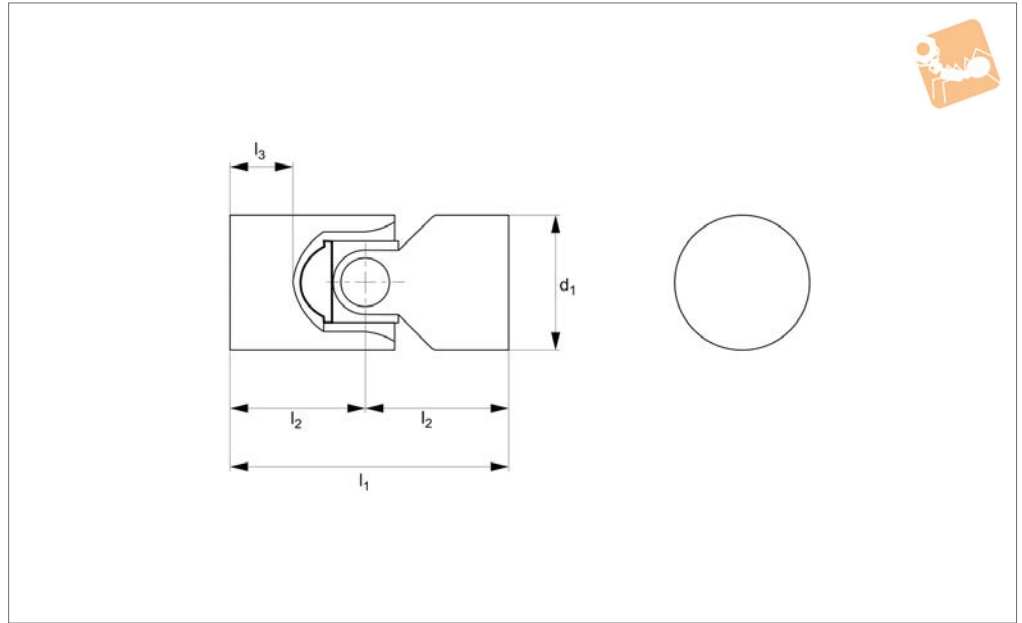

Material

Stainless steel (AISI 304), bearing type: Plain bearing.

Maximum bending angle 45° per joint.
Max. drive speed of joints with journal bearings 1000 rpm.

shafts off-set towards each other.
Product variations available on request: square bores and hex bores.

Technical Notes

To DIN 808.

Tips

Single universal joints are used where

Order No.	Bore dia.	d tol. h4	l_1	l_2	l_3	Weight g
R3695.013	Unbored	13	43	21	14	20
R3695.017	Unbored	17	53	26	18	50
R3695.020	Unbored	20	63	31	21	70
R3695.025	Unbored	25	57	28	16	150
R3695.026	Unbored	25	75	37	25	150
R3695.032	Unbored	32	87	43	26	290
R3695.040	Unbored	40	109	54	34	600
R3695.050	Unbored	50	133	66	42	1160



Stainless 316 Single Universal Joint

Stainless unbored - solid ends

Universal Joints

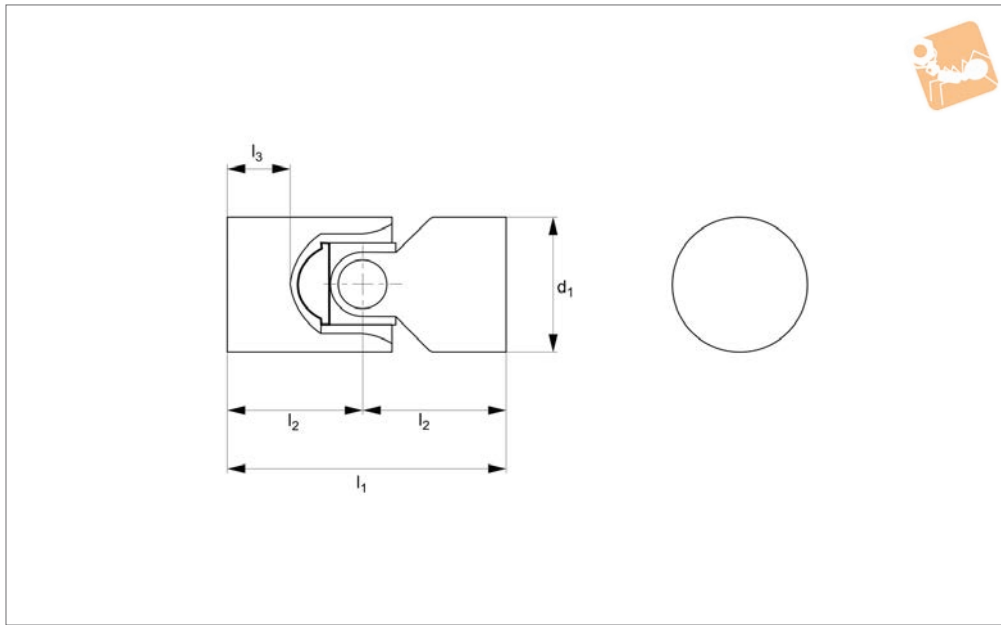

R3698

UNIVERSAL JOINTS

Material

Stainless steel (AISI 316), bearing type: Plain bearing.

Technical Notes

To DIN 808.
Maximum bending angle 45° per joint.
Max. drive speed of joints with journal bearings 100 rpm.

Tips

Single universal joints are used where

shafts off-set towards each other.
Product variations available on request: square bores and hex bores.
Can be disassembled to aid machining of ends.

Assembly instructions:

Step 1: Spray with grease internal high load spray adhesive (type TG248) ball and holes in the forks.
Step 2: Place sphere inside fork 1 and insert long pin with planes oriented

towards perpendicular hole in the sphere.
Step 3: Insert fork 2 on the ball and fit inside the short flared pin subsequently, on the opposite side, the short threaded pin.
Step 4: Place the countersunk screw tightening it adequately.
Step 5: Screw the locking dowel on the pin short threaded against the screw.

Order No.	d ₁	l ₁	l ₂	l ₃
R3698.020-UN	20	62	31	19
R3698.025-UN	25	74	37	23
R3698.032-UN	32	86	43	25
R3698.040-UN	40	108	54	30
R3698.050-UN	50	132	66	40

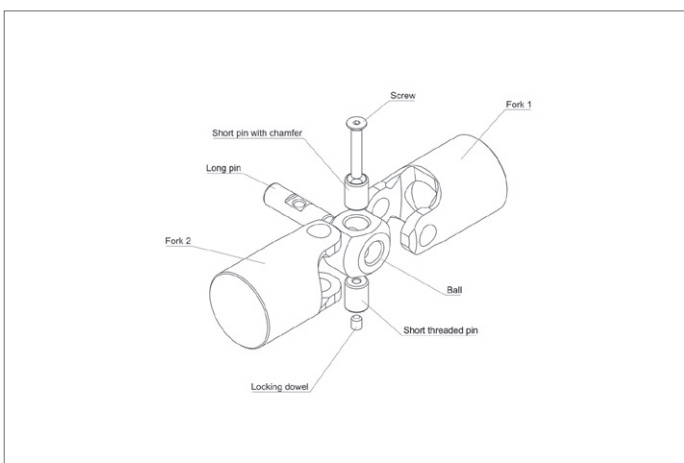



R3696

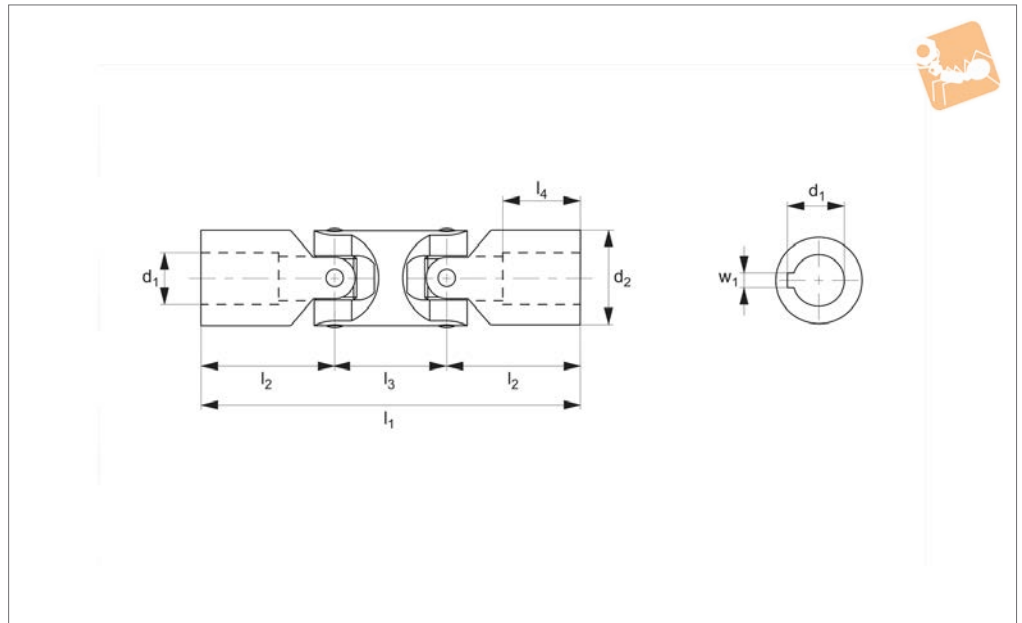

Material
Stainless steel (AISI 304).

Technical Notes
To DIN 808, maximum bending angle 45°

per joint.

Tips
Product variations available on request, for square bores change the suffix to SQ for

square bores or HX for hex bores.

Order No.	Bore dia.	d ₁ tol. H7	d ₂	l ₁	l ₂	l ₃	l ₄	w ₁	w ₂	Weight g
R3696.006-RB	Round Bore	6	16	56	17	22	8	-	-	80
R3696.008-RB	Round Bore	8	16	62	20	22	11	-	-	80
R3696.010-RB	Round Bore	10	22	74	24	26	12	-	-	150
R3696.012-RB	Round Bore	12	25	86	28	30	13	-	-	250
R3696.016-RB	Round Bore	16	32	104	34	36	16	-	-	450
R3696.020-RB	Round Bore	20	42	128	41	46	18	-	-	1000
R3696.025-RB	Round Bore	25	50	163	54	55	26	-	-	2000
R3696.030-RB	Round Bore	30	58	190	61	68	29	-	-	2900
R3696.006-KW	Keyway	6	16	56	17	22	8	2	7.0	80
R3696.008-KW	Keyway	8	16	62	20	22	11	2	9.0	80
R3696.010-KW	Keyway	10	22	74	24	26	12	3	11.4	150
R3696.012-KW	Keyway	12	25	86	28	30	13	4	13.8	250
R3696.016-KW	Keyway	16	32	104	34	36	16	5	18.3	450
R3696.020-KW	Keyway	20	42	128	41	46	18	6	22.8	1000
R3696.025-KW	Keyway	25	50	163	54	55	26	8	28.3	2000
R3696.030-KW	Keyway	30	58	190	61	68	29	8	33.3	2900



Stainless Double Universal Joint

Stainless unbored - solid ends

Universal Joints

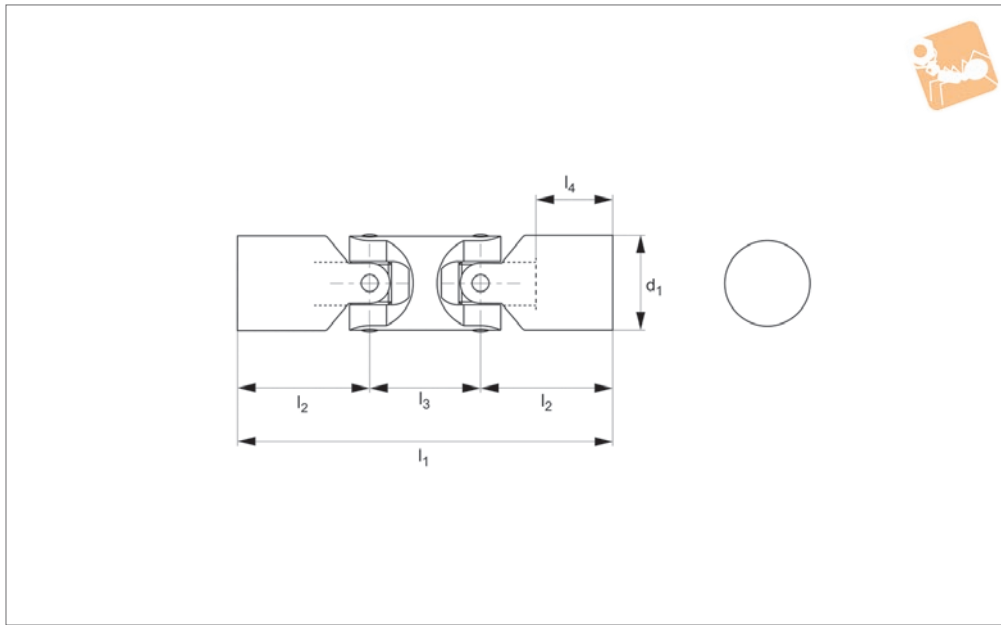

R3697

UNIVERSAL JOINTS

Material

Stainless steel (AISI 304), bearing type: Plain bearing.

Maximum bending angle 45° per joint.
Max. drive speed of joints with journal bearings 1000 rpm.

Large bending angles are required or where two shafts offset in relation to each other.
Product variations available on request: square bores and hex bores.

Technical Notes

To DIN 808.

Tips

Double universal joints are used where

Order No.	Bore dia.	d ₁ tol. H4	l ₁	l ₂	l ₃	l ₄	Weight g
R3697.013	Unbored	13	61	21	18	14	50
R3697.017	Unbored	17	63	20	22	12	80
R3697.018	Unbored	17	75	26	22	18	80
R3697.020	Unbored	20	89	31	26	21	150
R3697.025	Unbored	25	87	28	30	16	250
R3697.026	Unbored	25	105	37	30	25	350
R3697.032	Unbored	32	125	43	38	26	450
R3697.040	Unbored	40	155	54	46	34	1000
R3697.050	Unbored	50	189	66	56	42	2000
R3697.060	Unbored	60	237	83	70	53	3000



When one single joint is coupled with two shafts (of which the driving one is rotating at a constant speed) forming an angle, a periodic variation of the driven shaft is caused with exactly four fluctuations per revolution.

The difference between the maximum and the minimum speed of the driven shaft depends on the angle formed by the two shafts. The difference grows with the increase of the angle a° . To have a smooth transmission, either two opposite single joints (ensuring that the two central yokes lie on the same plane and the angles are equal) or a double joint need to be fitted. The irregularity caused by the articulation of the first unisex joint is cancelled by the second unisex joint. The overall length resulting from the coupling of the two single joints can be reduced by using a double unisex joint. In other words, the double joint is to be considered as the shortest method of achieving smooth transmission.

For low speed applications (max. 1000 rpm), joints with plain bearings are recommended. They are able to support shock loads, motion reversal, irregular running and relatively high torques. The working angles must be restricted when using at speeds between 500 - 1000 rpm. Please consult our technical department if you have such an application.

For high rotation speeds, relatively low torques or wide angles, joints with needle roller bearings are preferred. They can reach 4000 rpm dependent on the angle.

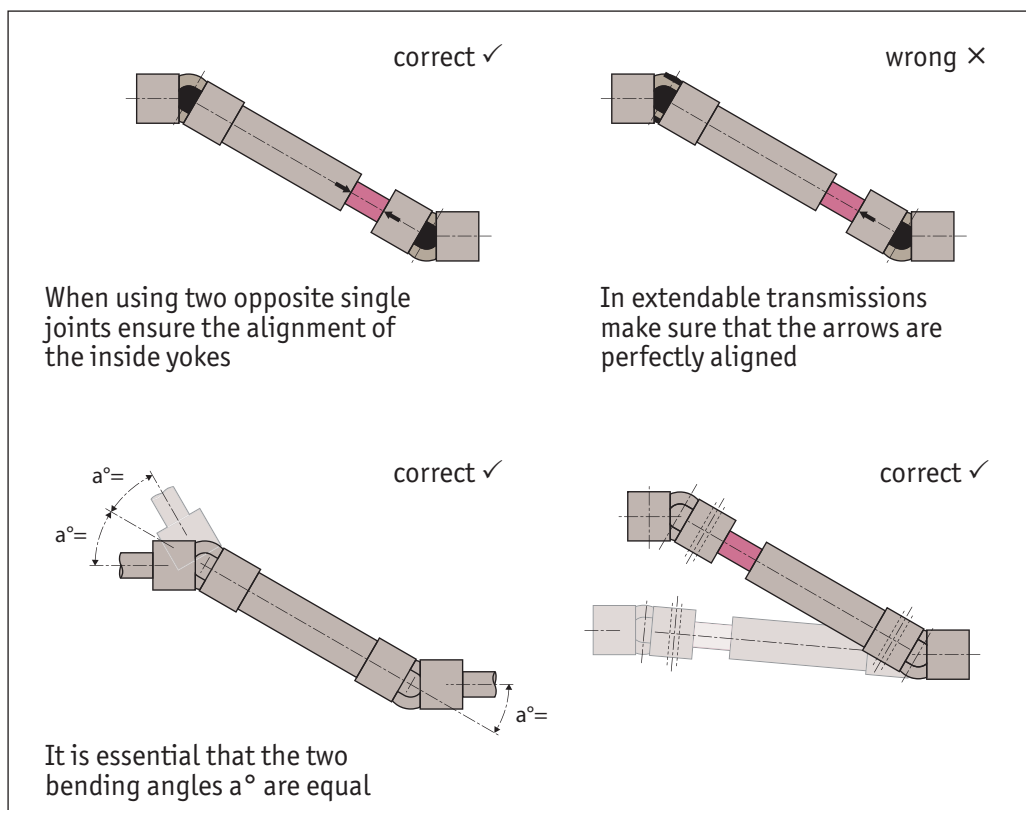
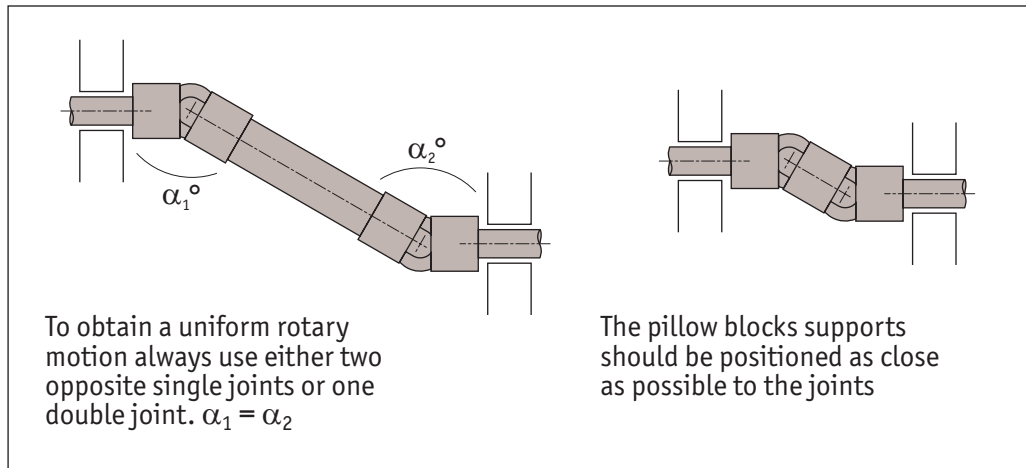



How to read diagrams

The joints capacity to transmit a regular torque at a constant load with no shocks, for a long period, mainly depends on the number of revolutions per minute and the inclination angle a° of the two axes. The diagrams on the following pages are based on this. Each curve corresponds to the joint size (outside diameter "D") and represents the torque that the joint can transmit depending on speed and working angle a° .

The diagrams can be directly read if angle (a°) is 10° . For wider angles, torques are reduced, these should be corrected using the correction vales (F) relating to the angle shown in the table.

IMPORTANT

Graph values are merely indicative and refer to the single joints only. When choosing a double joint, you have to consider that they can transmit a torque about 10% lower than the same sized single joints. Each application has its own particular motion characteristics, such as: shock loads, motion reversals, connected masses, kind of starting, presence of elastic joints, stops and starts, etc., that have to be considered when choosing the joint.

Working angle a°	Correction value F
5°	1,25
10°	1,00
15°	0,80
20°	0,65
25°	0,55
30°	0,45
35°	0,38
40°	0,30
45°	0,25

Torque Calculation for Plain Bearings

Power: 0,65 KW, RPM: 230

With working angle 10° Value $F = 1$ we get point P. Torque = 27 Nm corresponding to joint size "D" = 25/26mm. = Types R3688.016 and R3689.012

With working angle 30° Value $F = 0.45$ (Kw 0,65: 0,45 = 1,44Kw) we get point P1 Torque = 60 Nm corresponding to joint size "D" = 32mm. = Types R3688.020 and R3689.016

Consider that:

$$\text{Torque in Nm} = 9550 \times \frac{\text{Power (KW)}}{\text{RPM}}$$

$$\text{Torque in Nm} = 7020 \times \frac{\text{Power (HP)}}{\text{RPM}}$$

Note: 1 KW = 1,35 HP and HP = 0,736 KW

Note: 1 Kgm = 9,81 Nm and Nm = 0,102 Kgm



Plain Bearings Single & Double

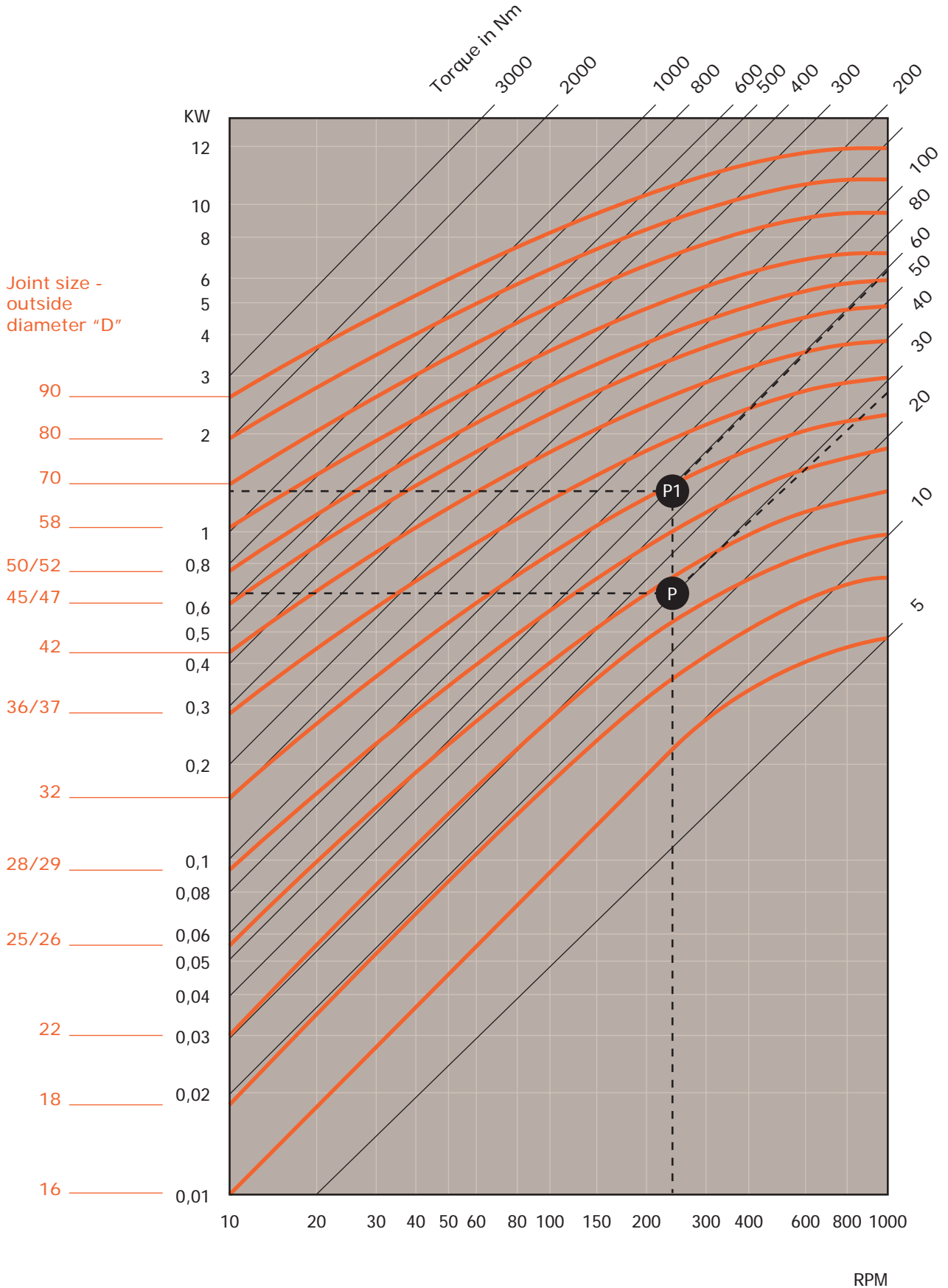

*For double reduce Torque by 15%



Working angle a °	Correction value F
5°	1,25
10°	1,00
15°	0,90
20°	0,80
25°	0,70
30°	0,50
35°	0,40
40°	0,30
45°	0,25

Torque Calculation

Power: 0,55 KW, RPM: 2300

With working angle a 10° Value F = 1 we get point P. Torque = 23 Nm corresponding to joint size "D" = 28mm. = Type R3686.014

With working angle a 25° Value F = 0.70 (Kw 5,5: 0,70 = 7,85Kw) we get point P1 Torque = 33 Nm corresponding to joint size "D" = 32mm. = Type R3686.016

Consider that:

$$\text{Torque in Nm} = 9550 \times \frac{\text{Power (KW)}}{\text{RPM}}$$

$$\text{Torque in Nm} = 7020 \times \frac{\text{Power (HP)}}{\text{RPM}}$$

Note: 1 KW = 1,35 HP and HP = 0,736 KW

Note: 1 Kgm = 9,81 Nm and 1Nm = 0,102 Kgm

Factor in a safety factor for shock load, recipricating methods, start up shocks etc.

Universal Joints from Automation Components

UNIVERSAL JOINTS



Needle Roller Bearing Single & Double

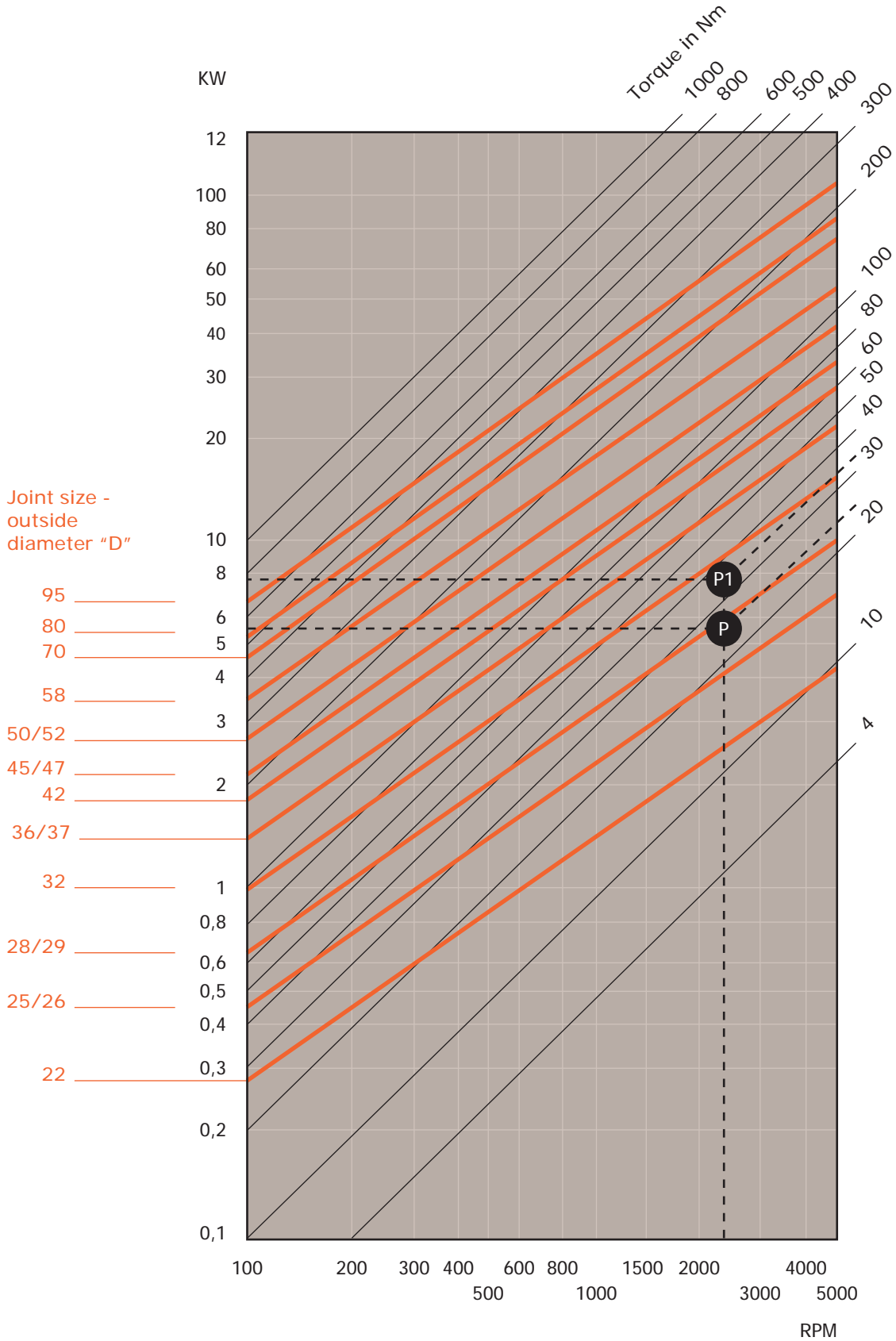

*For double reduce Torque by 15%