

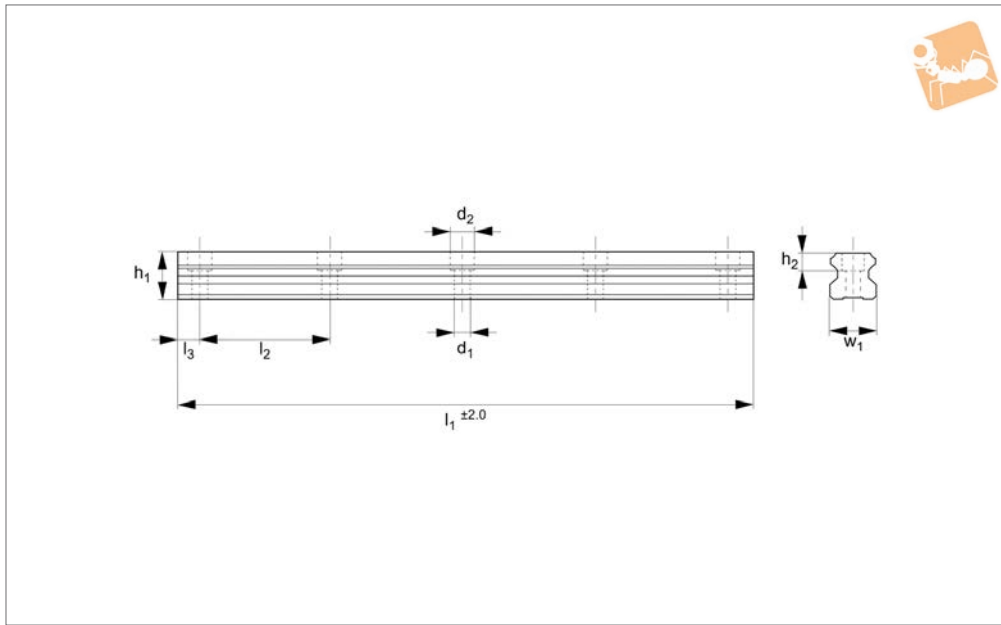

30mm Linear Guide Rail

standard

Linear Guide-ways



L1016.30

LINEAR GUIDEWAYS

Material

Hardened and ground steel (typically 60 HRC).

part nos. L1016.F (flanged) and L1016.U (unflanged).

Other rail lengths on request.
Weight: 5,2 Kg/m.

Tips

Plastic screw covers issued with the rails to protect the holes from debris.

Technical Notes

For carriages to suit the required load see

Order No.	Rail size	l_1	h_1	l_2	w_1	l_3	h_2	d_1	d_2	For screws	Weight kg
L1016.30-0200	30	200	22.8	80	28	20	12	9	14	M8	1.04
L1016.30-0280	30	280	22.8	80	28	20	12	9	14	M8	1.46
L1016.30-0360	30	360	22.8	80	28	20	12	9	14	M8	1.87
L1016.30-0440	30	440	22.8	80	28	20	12	9	14	M8	2.29
L1016.30-0520	30	520	22.8	80	28	20	12	9	14	M8	2.70
L1016.30-0600	30	600	22.8	80	28	20	12	9	14	M8	3.12
L1016.30-0680	30	680	22.8	80	28	20	12	9	14	M8	3.54
L1016.30-0760	30	760	22.8	80	28	20	12	9	14	M8	3.95
L1016.30-0840	30	840	22.8	80	28	20	12	9	14	M8	4.37
L1016.30-0920	30	920	22.8	80	28	20	12	9	14	M8	4.78
L1016.30-1000	30	1000	22.8	80	28	20	12	9	14	M8	5.20
L1016.30-1080	30	1080	22.8	80	28	20	12	9	14	M8	5.62
L1016.30-1160	30	1160	22.8	80	28	20	12	9	14	M8	6.03
L1016.30-1240	30	1240	22.8	80	28	20	12	9	14	M8	6.45
L1016.30-1320	30	1320	22.8	80	28	20	12	9	14	M8	6.86
L1016.30-1400	30	1400	22.8	80	28	20	12	9	14	M8	7.28
L1016.30-1480	30	1480	22.8	80	28	20	12	9	14	M8	7.70
L1016.30-1560	30	1560	22.8	80	28	20	12	9	14	M8	8.11
L1016.30-1640	30	1640	22.8	80	28	20	12	9	14	M8	8.53
L1016.30-1720	30	1720	22.8	80	28	20	12	9	14	M8	8.94
L1016.30-1800	30	1800	22.8	80	28	20	12	9	14	M8	9.36
L1016.30-1880	30	1880	22.8	80	28	20	12	9	14	M8	9.78
L1016.30-1960	30	1960	22.8	80	28	20	12	9	14	M8	10.19
L1016.30-2040	30	2040	22.8	80	28	20	12	9	14	M8	10.61
L1016.30-2120	30	2120	22.8	80	28	20	12	9	14	M8	11.02
L1016.30-2200	30	2200	22.8	80	28	20	12	9	14	M8	11.44
L1016.30-2280	30	2280	22.8	80	28	20	12	9	14	M8	11.86
L1016.30-2360	30	2360	22.8	80	28	20	12	9	14	M8	12.27
L1016.30-2440	30	2440	22.8	80	28	20	12	9	14	M8	12.69
L1016.30-2520	30	2520	22.8	80	28	20	12	9	14	M8	13.10
L1016.30-2600	30	2600	22.8	80	28	20	12	9	14	M8	13.52
L1016.30-2680	30	2680	22.8	80	28	20	12	9	14	M8	13.94



Order No.	Rail size	l_1	h_1	l_2	w_1	l_3	h_2	d_1	d_2	For screws	Weight kg
L1016.30-2760	30	2760	22.8	80	28	20	12	9	14	M8	14.35
L1016.30-2840	30	2840	22.8	80	28	20	12	9	14	M8	14.77
L1016.30-2920	30	2920	22.8	80	28	20	12	9	14	M8	15.18
L1016.30-3000	30	3000	22.8	80	28	20	12	9	14	M8	15.60
L1016.30-3080	30	3080	22.8	80	28	20	12	9	14	M8	16.02
L1016.30-3160	30	3160	22.8	80	28	20	12	9	14	M8	16.43
L1016.30-3240	30	3240	22.8	80	28	20	12	9	14	M8	16.85
L1016.30-3320	30	3320	22.8	80	28	20	12	9	14	M8	17.26
L1016.30-3400	30	3400	22.8	80	28	20	12	9	14	M8	17.68
L1016.30-3480	30	3480	22.8	80	28	20	12	9	14	M8	18.10
L1016.30-3560	30	3560	22.8	80	28	20	12	9	14	M8	18.51
L1016.30-3640	30	3640	22.8	80	28	20	12	9	14	M8	18.93
L1016.30-3720	30	3720	22.8	80	28	20	12	9	14	M8	19.34
L1016.30-3800	30	3800	22.8	80	28	20	12	9	14	M8	19.76
L1016.30-3880	30	3880	22.8	80	28	20	12	9	14	M8	20.18
L1016.30-3960	30	3960	22.8	80	28	20	12	9	14	M8	20.59
L1016.30-4000	30	4000	22.8	80	28	20	12	9	14	M8	20.80



L1016 Linear guideways

Linear guideways are widely used throughout industry for heavy-duty and precise applications.

Precision high load rails

The use of steel balls and the design of the carriages and guideways mean that the rails can accept very heavy loads and significant moment loads. Our rails have circular as opposed to friction coefficient, lower driving resistance, lower wear and lower energy consumption.

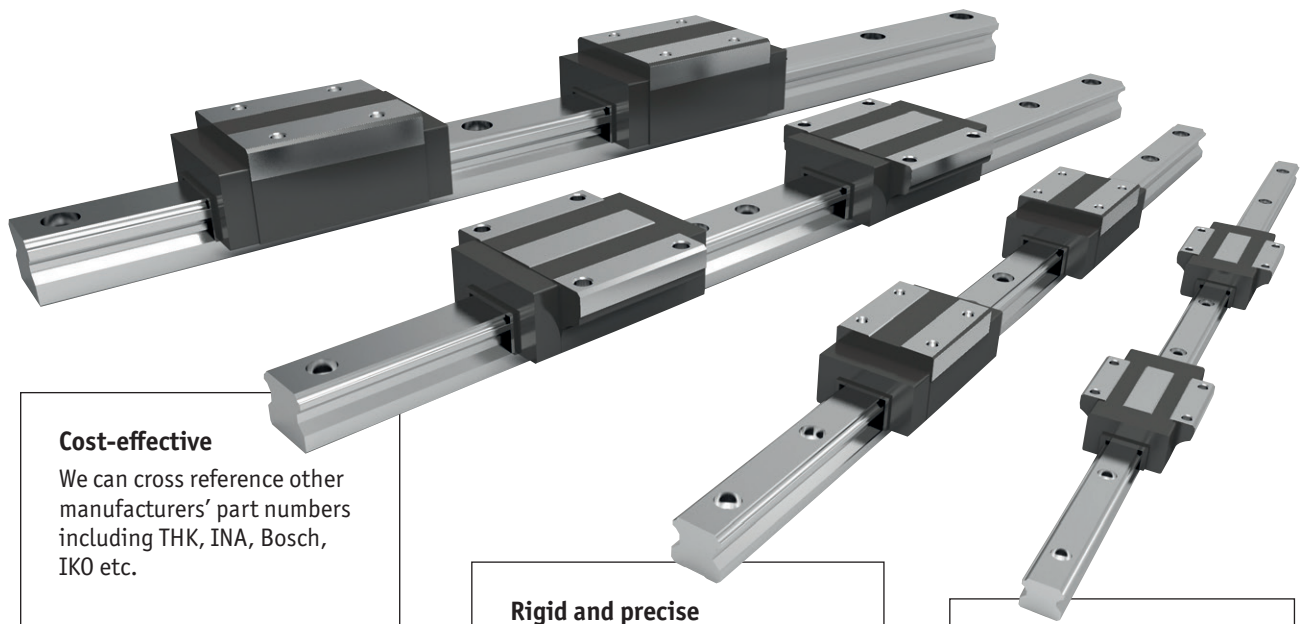

Cost-effective

We can cross reference other manufacturers' part numbers including THK, INA, Bosch, IKO etc.

Rigid and precise

- High load rating.
- High moment load capacity.

Stocked

7 rail profiles ready for same day despatch. Lengths up to 4 metres.

Rail sizes

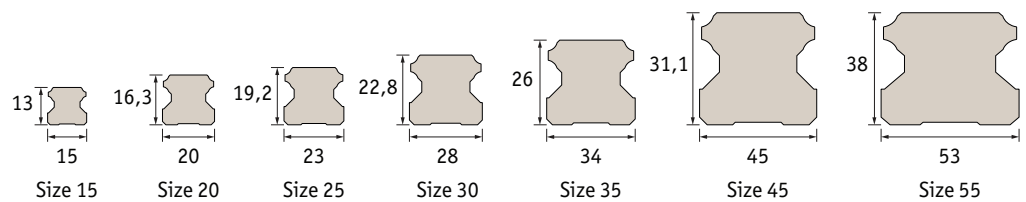

Load capacities – explained

- A number of load figures are stated for load capacity:

Dynamic Load – this is the main figure considered for linear guideways. It is the moving load that the system can bear. It takes account of the total moving load as well as considerations such as impact, vibration and fatigue.

Static Load – this is a load that is constant for an extended time (i.e. the dead load the system can bear before any movement). It can be in tension or compression.

For these linear guideways the radial and axial load capacities are the same.

Moment loads are twisting loads generated by offset loads in either X, Y or Z planes. Moment loads can be reduced by adding further carriages or rails to reduce any twisting of the carriage due to the load offset.

Straightness of rails

- The measurements of the straightness of the system are taken from the running accuracy of the sliders over the length of the rails (given in microns) – see system precision page.
- For standard accuracy this equates to around 20 microns for a metre length, increasing to 35 microns for a 4 metre length.

What lengths can be provided?

- We have standard rail lengths. These are based on the hole pitch of the rails and end machining to provide an equidistant length to the first and last hole centre.
- However we can cut the rail (from stock) to any length required – we just need to know the distance required to the first hole.
- In general our cutting procedures allow for a ± 2 mm accuracy on the overall rail length. If greater accuracy than this is required then we have to machine the end accurately (rather than cut it) and this involves extra time and cost.
- Standard maximum length for each rail size is around 4 metres. Rails can be joined together but the preparation needs to be made in our workshop. The rails will be marked clearly with the ends to be placed adjacent to each other.

Installation

- The linear guideways are very accurate and as a result need to be installed on accurately prepared surfaces – please see installation instructions. If the two rails are installed parallel to each other, they need to be accurately aligned – see assembly precision page.
- If you are not able to prepare the surface as accurately as required you might want to consider using our Compact Rail system, as this has a master rail (T rail) and a slave rail (U rail) that allows for structural inaccuracies.

Mounting the carriages to the rails

- In general the carriages will be supplied separately to the rails. To install the carriage onto the rails, offer the carriage up to the rails and slide it onto the rail itself.

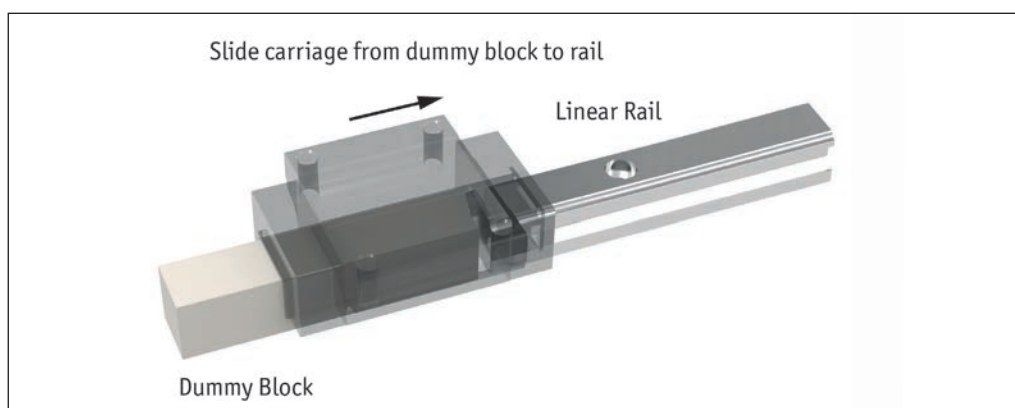



New ball chain technology

Our new and improved linear guideway systems include the latest “ball chain” technology with the following benefits:

- Higher maximum velocity.
- Lower heat generation
- Lower noise generation.
- Very smooth running.
- Optimised lubrication system
- Even load distribution
- Longer service life

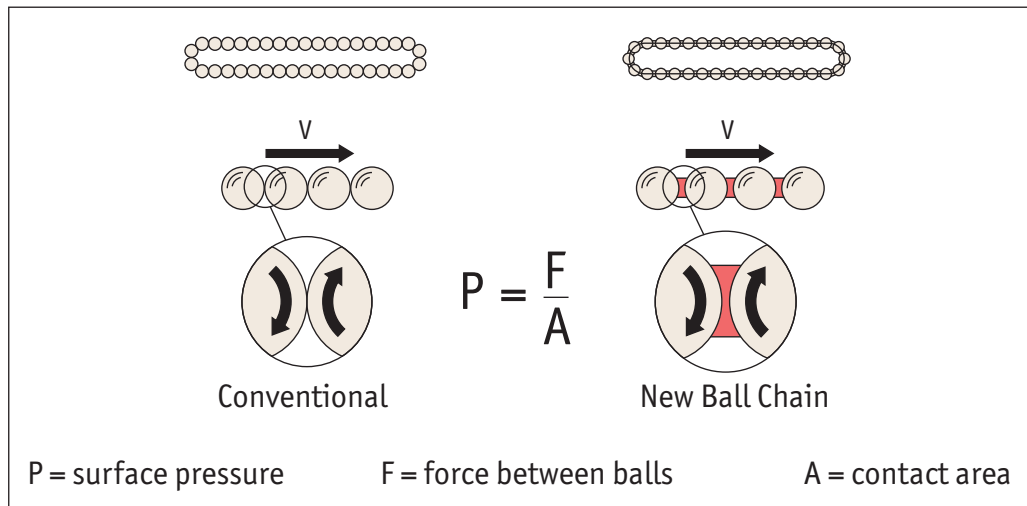

The rotating balls in conventional profile rail guides have point contact between each other. The rotation speed at the contact point is double the speed of the balls. The contact area (A) is so small that the surface pressure (P) tends towards infinity. This leads to heating and wear of the balls and the linear guide system.

The chain system in our new linear guides have a relatively large contact area (A), this significantly reduces the surface area pressure (P). The rotation speeds at the contact surfaces of ball and chain are the same. The ball chain is used to transport the lubricant and to create a lubrication film on the balls. The design of the carriage allows effective supply of lubricant from the lubricant connection to the circulation areas of the ball chains.

This design of the of the ball chain ends in connection with the spacer ball closes the circulation and makes the movement of the carriage smooth and quiet.

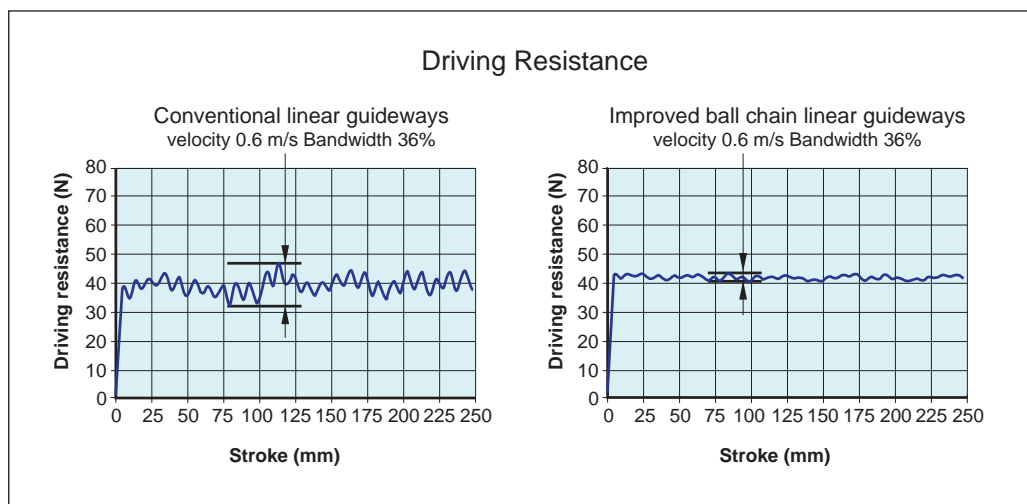

Linear Guideways from Automation Components

LINEAR GUIDEWAYS