

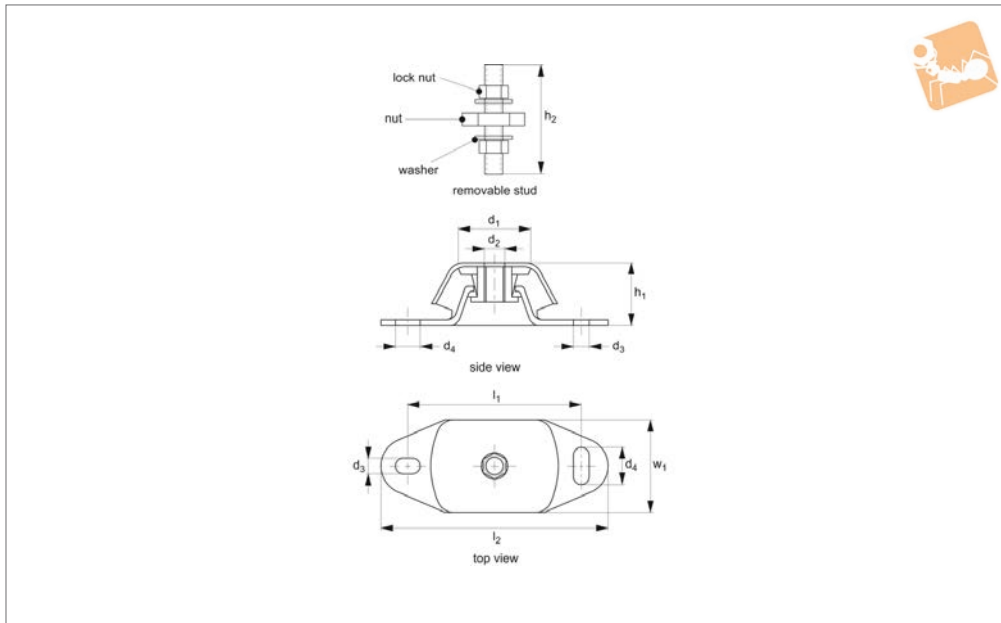

Anti-vibration Fail-Safe Mounts

A2 stainless

Anti-Vibration Components



P2101

ANTI-VIBRATION COMPONENTS

Material

Stainless steel (AISI 304), (rubber hardness 45-65 Shore A).

Technical Notes

These mounts control vibration in three axes.
Primarily used for marine applications, engines, compressors, pumps, generators etc.

Fitted with a mechanical fail-safe stop. They are very robust to cope with high start/stop forces and vibrations from marine and other engines.

The stainless steel versions are widely used for marine engine mounts or outdoor applications. For offshore or highly corrosive environments use part no. P2102.

Stud and nuts on request.

Tips

These are a very popular anti-vibration mount for light to heavy duty applications. Take the total weight of the load to be supported, divide it by the number of mounts to be used and select an appropriate mount from the table.

Order No.	d ₁	d ₂	l ₁	l ₂	w ₁	d ₃	d ₄	h ₁	h ₂	Load kg max.
P2101.60-65	60	M12	100	120	60	11	14	40	95	100
P2101.75-65	75	M16	140	183	75	13	20	50	110	300
P2101.60-45	60	M12	100	120	60	11	14	40	95	50
P2101.60-55	60	M12	100	120	60	11	14	40	95	65
P2101.75-45	75	M16	140	183	75	13	20	50	110	150
P2101.75-55	75	M16	140	183	75	13	20	50	110	200



Recommendations for machine mounts

Machine mounts should be installed between two parallel and perfectly flat surfaces. Mounts operating tilted or twisted do not work properly. This may be due to incorrect alignment, tolerances in the building of the structure or over-tightened torque during the installation of the anti-vibration mounts.

