

P2186

LEVELLING FEET

Material

Steel (type 42 CrMo4 V, 1.7225) zinc plated or stainless steel A1 (A4 on request).

Technical Notes

Compensates for non-level surfaces with a maximum angle of tilt 4° . Please remember

that the fixing screw and washer may also require support if the bearing surface is out of parallel by more than 1° . The ball shim has no height adjustment feature.

Order No.	Material	For bolt	d_1	d_2	d_3	h	α app.
P2186.008-060-ZP	Steel	M 6	25	15	8.5	8.0	4°
P2186.010-100-ZP	Steel	M10	32	20	13.0	10.0	4°
P2186.012-160-ZP	Steel	M16	45	30	20.0	12.5	4°
P2186.016-240-ZP	Steel	M24	58	38	29.0	16.0	4°
P2186.020-300-ZP	Steel	M30	70	48	36.0	20.0	4°
P2186.020-360-ZP	Steel	M36	80	61	44.0	20.0	4°
P2186.020-480-ZP	Steel	M48	105	78	58.0	25.0	4°
P2186.008-060-A2	Stainless steel	M 6	25	15	8.5	8.0	4°
P2186.010-100-A2	Stainless steel	M10	32	20	13.0	10.0	4°
P2186.012-160-A2	Stainless steel	M16	45	30	20.0	12.5	4°
P2186.016-240-A2	Stainless steel	M24	58	38	29.0	16.0	4°
P2186.020-300-A2	Stainless steel	M30	70	48	36.0	20.0	4°
P2186.020-360-A2	Stainless steel	M36	80	61	44.0	20.0	4°
P2186.020-480-A2	Stainless steel	M48	105	78	58.0	25.0	4°



Advantages

- Precision adjusting and re-adjusting.
- Operational under heavy loads.
- Fast installation.
- Greater vertical alignment (from 4 to 105mm).
- Compensation for non-parallel bearing surfaces.
- Suitable for static and dynamic loads.
- Can be anchored to foundation.

Applications

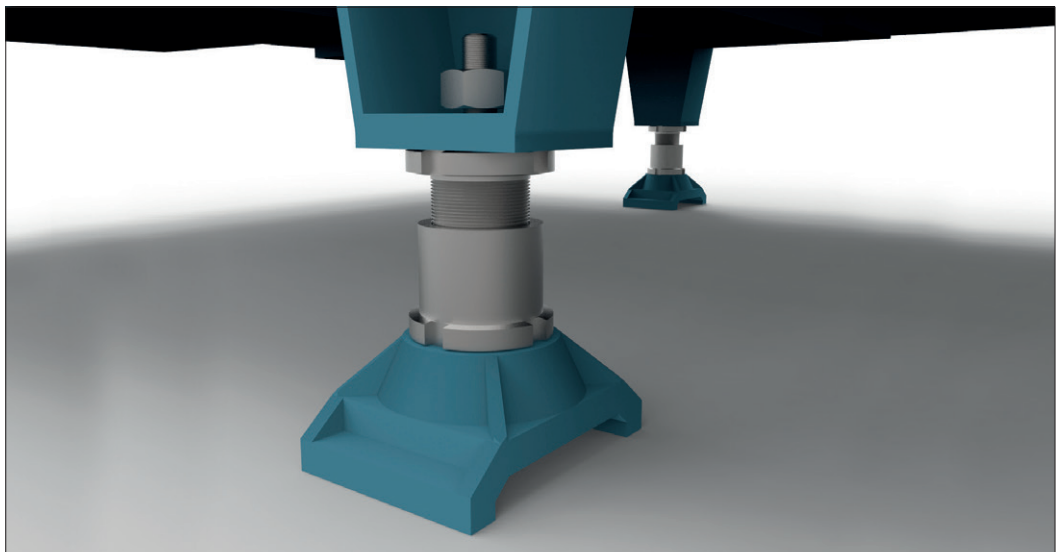

Grounded field mount - Precision Leveller no. 62060 in use on a fully metal encapsulated gas-insulated high voltage switch.



Test stand - Precision Levellers provide adjustment for the connection shaft between motor and transmission.

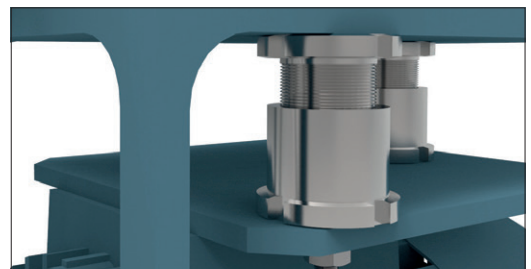

Drive train application - in this application Wixroyd Precision Levellers are used to adjust the rig to ensure correct tension of the V-belt, and to provide full support of the top mounted electric drive motor.



Plummer blocks - even multiple bearings can be levelled easily and precisely, here part no. 62000 is in use.

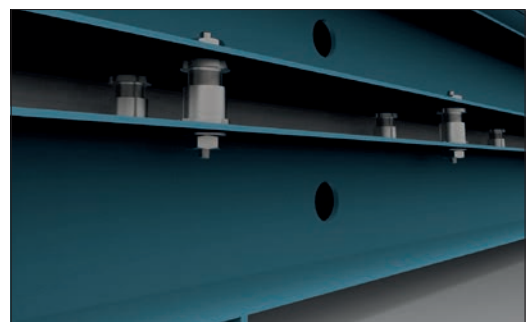

Extruder - precision adjustment of an extruder with leveller no. 62008.



Precision Levelling Adjusters

62000 - 62160
Materials Handling

Design features

Wixroyd Precision Levelling Adjusters enable accurate levelling, locating and adjusting of motors, machinery and much more, under heavy loads.

There are three key features to the design, firstly the fine threaded mounting bolt, secondly the threaded nut base and thirdly the end-stop. The fine thread of the mounting bolt and base provides precise adjustment, as well as easy re-adjustment by means of a hook spanner to DIN 1810A, see part no. 95400.

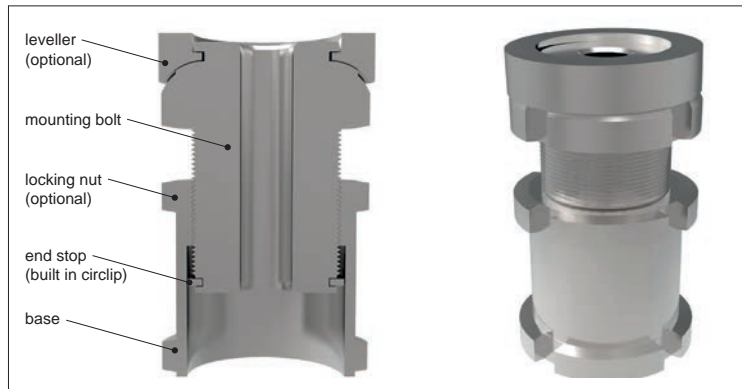

62000 - Designed for applications with limited space - height adjustment is between 4 and 14mm.



62040 - Designed for applications requiring both height adjustment (from 4 to 14mm) and precise adjustment of non-parallel surfaces, with a maximum angle of tilt 4°.



62060 - Designed for applications where a wide adjustment range is required - height adjustment equal to 15 to 55mm.



62080 - Designed for applications with a dynamic load, or where no fasteners are used. The locknut enables locking of the adjuster in the pre-set position.



62100 - For applications requiring both height adjustment (from 15 to 55mm) and precise adjustment of non-parallel surfaces, with a max. angle of tilt 4°.



62120 - The same features as part number 62100, but with the added feature of a locknut to fix adjuster in any position.



62140/62160 - Designed for applications requiring precise adjustment of non-parallel surfaces, with a maximum angle tilt 4°. The ball shim has no height adjustment feature.

Product range

Adjusters vs. levellers

Precision adjusters

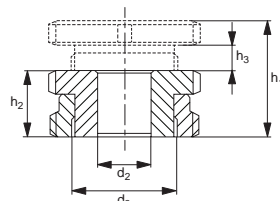

Precision levellers

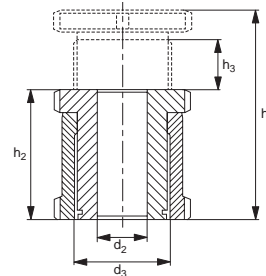

Features	62000	62002	62040	62042	62060	62080	62100	62120
Adjustment travel 4-14mm	✓	✓	✓	✓				
Adjustment travel 15-55mm					✓	✓	✓	✓
Lock nut		✓		✓		✓		✓
Slope adjustment up to 4°			✓	✓			✓	✓
Captive screw feature	✓	✓	✓	✓	✓	✓	✓	✓