

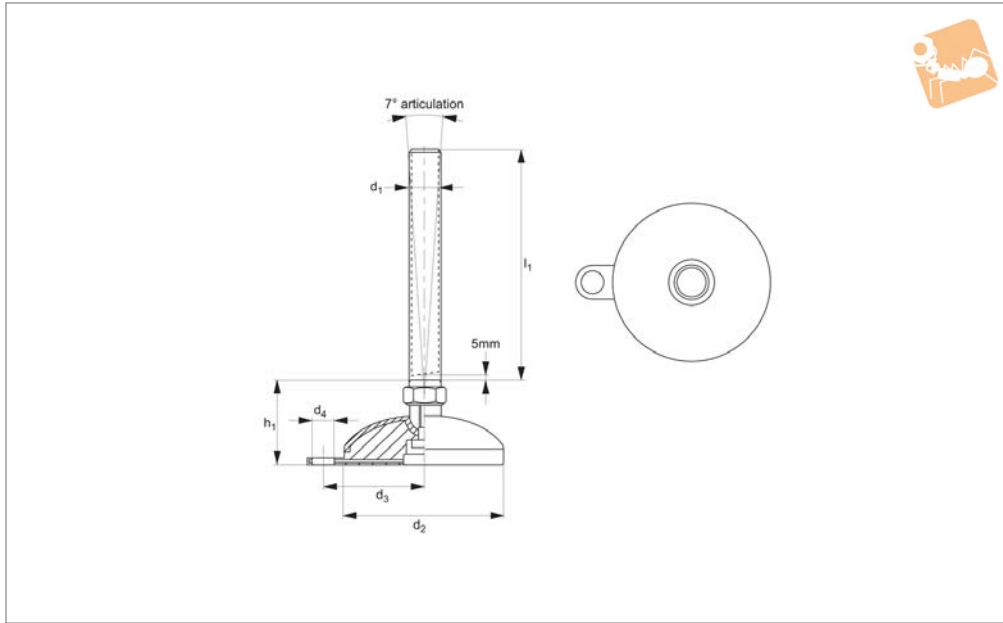

Machine Mount - Bolt Down pad and bolt - stainless steel



Levelling Feet



P2202

LEVELLING FEET

Material

Pad: pressed stainless steel AISI 303.
Bolt: stainless steel AISI 303.
Pad insert: nitril rubber.

machine mount to be fixed in place.

Tips

For use in wide range of industries including food processing, medical equipment, electronics and machinery workshops.

Technical Notes

Use of the bolt down tag allows the

Order No.	d ₁	l ₁	d ₂	d ₃	d ₄	h ₁	Static load kN max.
P1954.663	M16	150	75	52	13	33	7.5
P1954.665	M16	100	100	67	13	38	10.0



All levelling feet can be produced with the following fixing types:

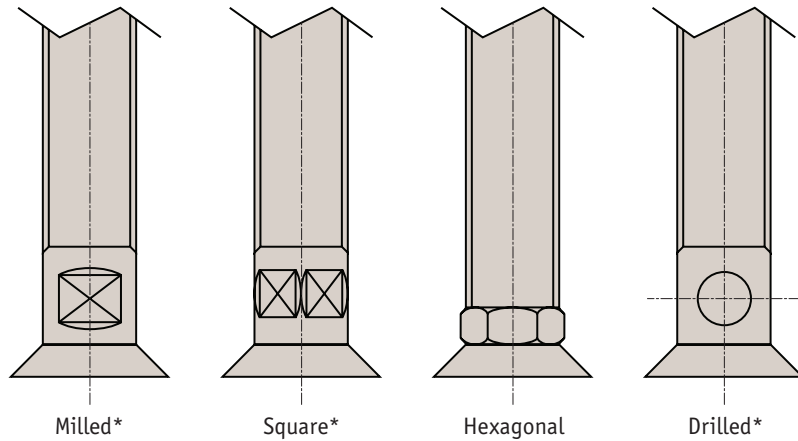
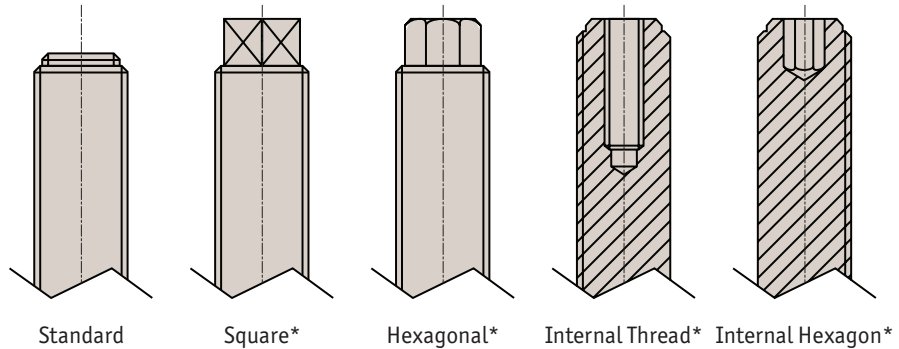

Thread versions

- Metric thread - coarse pitch (standard)
- Metric thread - fine pitch
- Thread gas 55°
- Imperial thread Unc
- Whitworth thread

* For non-standard threads a minimum order will apply.

Levelling Feet from Automation Components

LEVELLING FEET