

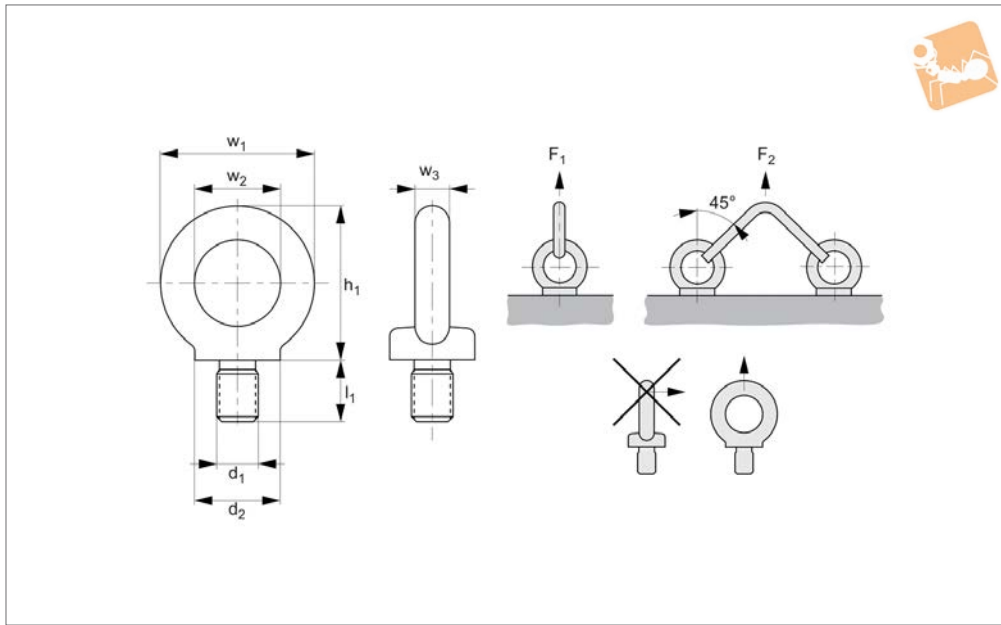

# Steel Male Lifting Eye Bolts

inch sizes

# Lifting Pins, Lifting Bolts &



**P4046**

LIFTING PINS, LIFTING BOLTS & SWING BOLTS

**Material**

Forged steel (C15E) annealed and zinc-plated (-ZP). Contact face machined. CE marked.

Hot dipped galvanised versions (for more demanding applications and limited outside use) also available on request, suffix changes to -GV.

**Technical Notes**

To DIN 580.

When using lifting eye bolts it is critical to ensure that the face is in firm contact with

the mating surface.

These lifting bolts are generally installed and remain on a piece of equipment for the purpose of transporting them. They are not for repeated lifting use - if this is required our swivelling lifting bolt range should be used.

**Tips**

Maximum load values are only applicable when the thread and the material, it is being used in is as least as strong as the

that of the bolt.

$F_1$  and  $F_2$  values given are for steel and cast iron components.

**Important Notes**

Not to be used at lift angles of greater than 45° or with swivelling loads.

**Please refer to the safety documentation before using this part.**

**Supplied with certificate and operating instructions.**

Order No.	d <sub>1</sub>	Thread type	d <sub>2</sub>	w <sub>1</sub>	l <sub>1</sub>	h <sub>1</sub>	w <sub>2</sub>	w <sub>3</sub>	F <sub>1</sub> kg max.	F <sub>2</sub> kg max.	Weight kg
P4046.U1/4-ZP	1/4"-20	UNC	20	36	13.0	36	20	8	70	50	0.06
P4046.U5/16-ZP	5/16"-18	UNC	20	36	13.0	36	20	8	140	95	0.06
P4046.U3/8-ZP	3/8"-16	UNC	25	45	17.0	45	25	10	230	170	0.11
P4046.U1/2-ZP	1/2"-12	UNC	30	54	20.5	53	30	12	340	240	0.18
P4046.U5/8-ZP	5/8"-11	UNC	35	63	27.0	62	35	14	700	500	0.28
P4046.U3/4-ZP	3/4"-10	UNC	40	72	30.0	71	40	16	1200	830	0.45
P4046.U7/8-ZP	7/8"-9	UNC	50	90	36.0	90	50	20	1500	1050	0.74
P4046.U1-ZP	1"-8	UNC	50	90	36.0	90	50	20	1800	1270	0.74
P4046.U1-1/8-ZP	1-1/8"-7	UNC	65	108	45.0	109	60	24	2500	1650	1.66
P4046.U1-1/4-ZP	1-1/4"-7	UNC	75	126	54.0	128	70	28	4300	3200	2.65
P4046.U1-1/2-ZP	1-1/2"-6	UNC	85	144	63.0	147	80	32	6100	4300	4.03
P4046.U1-3/4-ZP	1-3/4"-5	UNC	100	166	68.0	168	90	38	8000	5500	6.38
P4046.U2-ZP	2"	UNC	100	166	68.0	168	90	38	9900	7300	6.38
P4046.U2-1/4-ZP	2-1/4"	UNC	110	184	78.0	187	100	42	11500	8300	8.80
P4046.U2-1/2-ZP	2-1/2"	UNC	120	206	90.0	208	110	48	16000	11000	12.40
P4046.W1/4-ZP	1/4"-20	BSW	20	36	13.0	36	20	8	70	50	0.06
P4046.W5/16-ZP	5/16"-18	BSW	20	36	13.0	36	20	8	140	95	0.06
P4046.W3/8-ZP	3/8"-16	BSW	25	45	17.0	45	25	10	230	170	0.11
P4046.W1/2-ZP	1/2"-12	BSW	30	54	20.5	53	30	12	340	240	0.18
P4046.W5/8-ZP	5/8"-11	BSW	35	63	27.0	62	35	14	700	500	0.28
P4046.W3/4-ZP	3/4"-10	BSW	40	72	30.0	71	40	16	1200	830	0.45
P4046.W7/8-ZP	7/8"-9	BSW	50	90	36.0	90	50	20	1500	1050	0.74
P4046.W1-ZP	1"-8	BSW	50	90	36.0	90	50	20	1800	1270	0.74



Order No.	d <sub>1</sub>	Thread type	d <sub>2</sub>	w <sub>1</sub>	l <sub>1</sub>	h <sub>1</sub>	w <sub>2</sub>	w <sub>3</sub>	F <sub>1</sub> kg max.	F <sub>2</sub> kg max.	Weight kg
P4046.W1-1/8-ZP	1-1/8"-7	BSW	65	108	45.0	109	60	24	2500	1650	1.66
P4046.W1-1/4-ZP	1-1/4"-7	BSW	75	126	54.0	128	70	28	4300	3200	2.65
P4046.W1-1/2-ZP	1-1/2"-6	BSW	85	144	63.0	147	80	32	6100	4300	4.03
P4046.W1-3/4-ZP	1-3/4"-5	BSW	100	166	68.0	168	90	38	8000	5500	6.38
P4046.W2-ZP	2"	BSW	100	166	68.0	168	90	38	9900	7300	6.38
P4046.W2-1/4-ZP	2-1/4"	BSW	110	184	78.0	187	100	42	11500	8300	8.80
P4046.W2-1/2-ZP	2-1/2"	BSW	120	206	90.0	208	110	48	16000	11000	12.40



# DIN 580 Lifting Eye Bolts

## mounting information & instructions

18843 -18866  
Clamping & Height Setting



**Important Note: DIN 580 lifting eye bolts are mainly intended for permanent mounting to components such as motors, switchgear cabinets and gears, and for transporting these items of equipment. Please take care to take particular note of the following advice.**

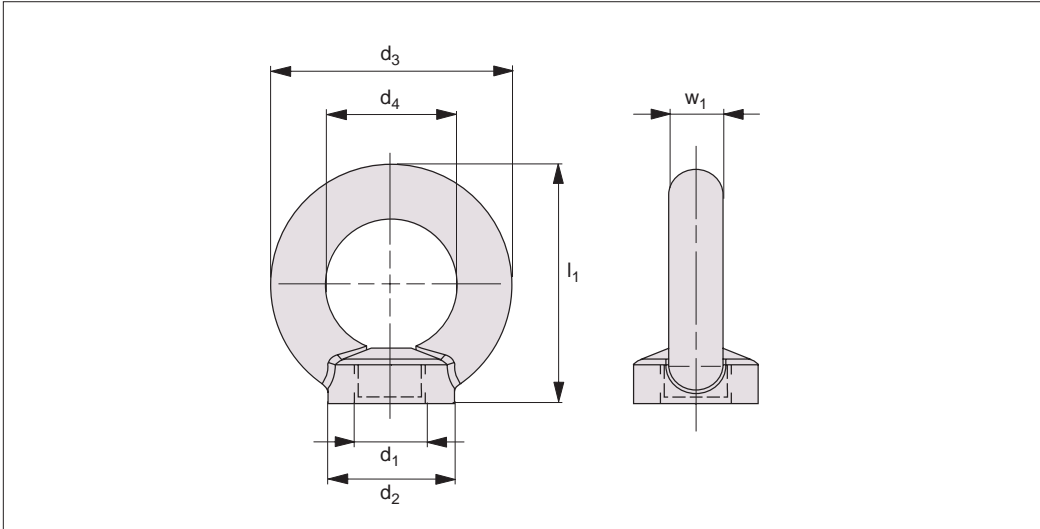

- 1) To be used by authorised, qualified and instructed personnel. Lifting eye bolts must be marked permanently raised with manufacturer's mark, material ID (e.g. C15E, A2 or A4), load-bearing capacity and axial direction (WLL in kg, see also Table/ F in N), and with CE symbol.
- 2) Check the lifting points for proper bolt seat, corrosion, wear and tear, deformation, etc. at regular intervals and before every use.
- 3) Select the lifting point such that the introduced forces are absorbed by the base material without any deformation. Screw-in depth for steel with a tensile strength of  $R_m > 340 \text{ N/mm}^2$ , e.g. S235JR (1.0037); or GG25 (0.6025 - without cavities or shrinkage):  $1.5 \times$  thread size  $d_1 (=L)$ . For screw-in material with lower strength, use lifting points with greater screw-in length. Minimum screw-in depths recommended:  $2 \times$  thread size  $d_1$  in aluminium alloys,  $2.5 \times$  thread size  $d_1$  in light metal with low strength. For light materials, non-ferrous metals and grey cast iron, select the thread such that the load-bearing capacity of the thread corresponds with the requirements involving the base material. For through-holes, a nut ( $0.8 \times d$ ) should be fully and firmly bolted from the opposite side. If the thread length of the screw is sufficient, the use of an additional washer is recommended.
- 4) Select the position of the fixing points to avoid swivel or load shifts.
  - a.) Arrange the lifting point for a single strand sling perpendicular above the load centre.
  - b.) Arrange the lifting points for a twin strand sling to ensure both sides are above the load centre. Caution: Avoid turning or rotating movements during transport!
  - c.) Position the eye bolt such that no shear tension acts on the eye bolt (illustration below, incorrect use). The introduced force must act in the direction of the eye bolt plane (illustration right, correct use).

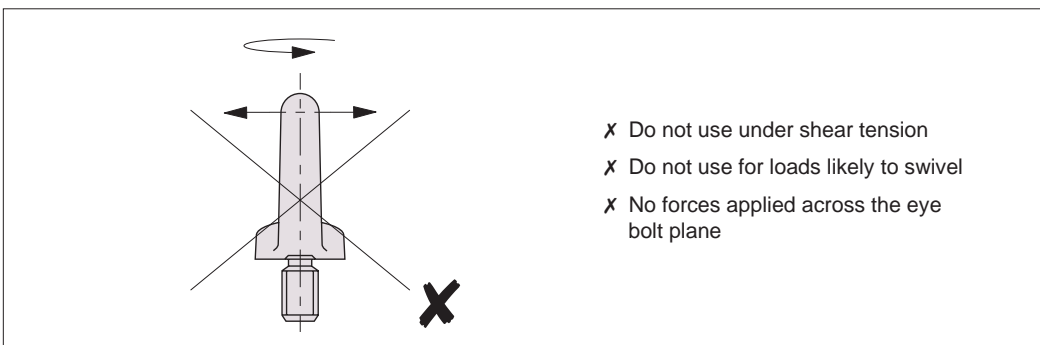

- X Do not use under shear tension
- X Do not use for loads likely to swivel
- X No forces applied across the eye bolt plane