

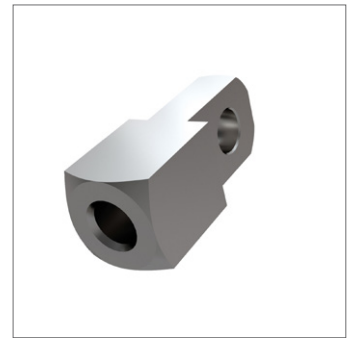

Stainless Mating Piece for Clevis

left hand thread

Clevis Joints & Clips

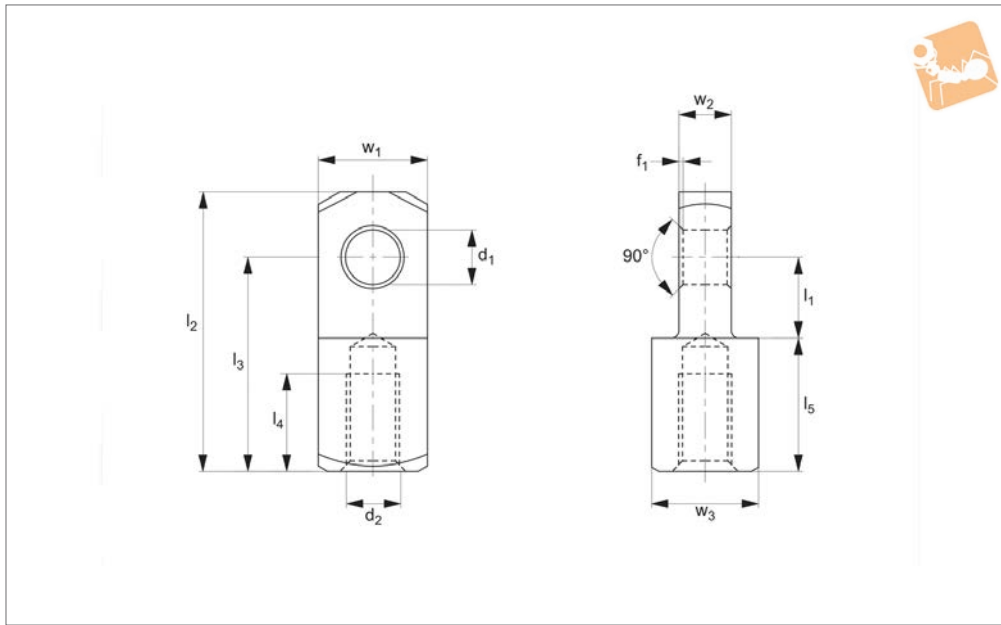

R3427

CLEVIS JOINTS & CLIPS

Material

Stainless steel (AISI 303 1.4305).

Tips

Thin end of mating piece is designed to fit

in between forks of clevis joint.

Designed so thread size matches clevis joint, (e.g. M5 mating piece will fit on M5 clevis joint).

Order No.	Thread hand	Thread type	d ₁ tol. H9	l ₁ ±0.5	d ₂	l ₂ ±0.5	l ₃ ±0.5	l ₄	l ₅ ±0.2	w ₁ tol. h11	w ₂ -0,2	w ₃ tol. h11	f ₁ ±0.2	Weight g
R3427.L004	Left	Coarse	4	6	M4	21	16	6	10.0	8	4	8	0.5	6
R3427.L005	Left	Coarse	5	7.5	M5	26	20	8	12.5	10	5	10	0.5	12
R3427.L006	Left	Coarse	6	9	M6	31	24	11	15.0	12	6	12	0.5	21
R3427.L008	Left	Coarse	8	12	M8	42	32	14	20.0	16	8	16	0.5	51
R3427.L009	Left	Fine	8	12	M8x1	42	32	14	20.0	16	8	16	0.5	51
R3427.L010	Left	Coarse	10	15	M10	52	40	18	25.0	20	10	20	0.5	98
R3427.L011	Left	Fine	10	15	M10x1,25	52	40	18	25.0	20	10	20	0.5	98
R3427.L012	Left	Coarse	12	18	M12	62	48	22	30.0	24	12	24	0.5	168
R3427.L013	Left	Fine	12	18	M12x1,25	62	48	22	30.0	24	12	24	0.5	167
R3427.L014	Left	Coarse	14	21	M14	72	56	25	35.0	27	14	27	1.0	247
R3427.L015	Left	Fine	14	21	M14x1,5	72	56	25	35.0	27	14	27	1.0	245
R3427.L016	Left	Coarse	16	24	M16	83	64	30	40.0	32	16	32	1.0	397
R3427.L017	Left	Fine	16	24	M16x1,5	83	64	30	40.0	32	16	32	1.0	395
R3427.L020	Left	Coarse	20	30	M20	105	80	38	50.0	40	20	40	1.0	783
R3427.L021	Left	Fine	20	30	M20x1,5	105	80	38	50.0	40	20	40	1.0	776



Parts overview

CLEVIS JOINTS & CLIPS

Clevis Joints

Stocked to DIN 71752 in steel and stainless steel. Plain clevis joints available in right and left hand threads zinc plated steel and stainless steel. Steel sizes from M4 up to M48. Stainless sizes from M4 up to M27.



Clevis Mating Pieces

These are designed to fit in between our clevis joints to create a linkage where an angular offset is required. Available in zinc plated steel and stainless steel. Sizes M4 up to M20.



Clevis Pins and Clips

Various styles of pins and clips to suit clevis joints in zinc plated steel and stainless steel. Sizes available to suit all sizes of clevis joints that we offer.



Clevis Retention Clips

These are the most popular type of clip used with our clevis joints. They create a neat compact assembly, only available in zinc plated steel. Size available for clevis joints from 4mm up to 20mm.



Male Clevis Joints

Stocked in zinc plated steel and stainless steel, right and left hand threads. Sizes M6 up to M20.





Clevis with retention clip
65630 and 65684



Clevis with clevis pin, washer and cotter pin
65660 and 65674



Zinc plated steel

Clevis with clevis pin 65664
Safety fastener 65680

Clevis with clevis pin and circlips 65666 and 65678



Clevis with clevis pin, washer and cotter pin 65661 and 65675



Stainless steel

Clevis with 65652 mating piece and 65684 clevis retention clip



Clevis with 65880 rod end and 65684 clevis retention clip



Assembly options

Tensile tests, statistically to failure (break)

Clevis joints axially loaded.

Leaded low carbon steel (AISI 12L14, 1.0718).

Clevises M6 - M42

Material

Clevis size	F min (kN)	F max (kN)	F average value (kN)	Avg. force when clevis starts to deform (kN)
6 x 24 M 6	16,0	19,5	17,6	15,3
8 x 32 M 8	33,2	35,6	34,6	29,3
10 x 40 M10	42,0	52,0	47,5	41,3
12 x 48 M12	53,0	68,5	61,1	50,2
14 x 56 M14	60,5	64,5	63,0	48,8
16 x 64 M16	133,5	146,0	140,2	115
20 x 40 M20	194,5	234,0	213,5	176
25 x 50 M25	311,0	336,0	328,0	260
30 x 60 M30	428,0	450,0	440,6	343
36 x 72 M36	566,0	573,0	569,5	300
35 x 72 M36	561,2	567,9	564,6	370
42 x 84 M42	904,6	904,6	904,6	420

Important note: values in this table are indicative only and should only be used as a rough guide. The Company cannot foresee the intended applications of their products and we accept no liability for any actions taken by third parties. Customers are advised to use their own safety factors and/or perform their own testing on the clevis joint to ensure it meets requirements for their application.