

R3582

ROD ENDS

Material

Housing: Black plastic (Igumid G)
Spherical Bearing: Iglidur w300

Technical Notes

Maintenance free, self lubricating. High strength under impact loads. Very high tensile strength for varying loads. Resistant to dirt and dust, resistant to

corrosion and chemicals, standard thread is right hand thread. High vibration dampening capacity, suitable for rotating, oscillating and linear movements. Available with a metal sleeve to take a higher torque, (add -MS to part No.) Suitable for use with R3409 clevis joints.

Important Notes

Dimensional series E. *Denotes fine pitch thread. Short term max axial strength is up to 20 minutes. Any length of time greater than this is considered long term.

Order No.	Thread hand	d ₁ tol. E10	l ₁	d ₂	d ₃	d ₄	d ₅	l ₂	l ₃	w ₁	w ₂
R3582.R004	Right	4	22.5	M4	15	8.0	9.2	9.5	30.0	5	3.5
R3582.R005	Right	5	30.0	M5	19	9.0	11	12	39.5	6	4.4
R3582.R006	Right	6	30.0	M6	21	11.0	13	12	40.5	6	4.4
R3582.R008	Right	8	36.0	M8	24	13.0	16	16	48.0	8	6.0
R3582.R010	Right	10	43.0	M10	29	15.0	19	18	57.5	9	7.0
R3582.R011	Right	10	43.0	M10 x 1,25*	29	15.0	19	18	57.5	9	7.0
R3582.R012	Right	12	50.0	M12	34	18.0	22	20	67.0	10	8.0
R3582.R013	Right	12	50.0	M12 x 1,25*	34	18.0	22	20	67.0	10	8.0
R3582.R015	Right	15	61.0	M14	40	21.0	26	26	81.0	12	10.0
R3582.R017	Right	17	67.0	M16	46	24.0	30	27	90.0	14	11.0
R3582.R018	Right	17	67.0	M16 x 1,5*	46	24.0	30	27	90.0	14	11.0
R3582.R020	Right	20	77.0	M20 x 1,5*	53	27.0	34	31	103.5	16	13.0
R3582.R021	Right	20	77.0	M20 x 2,5	53	27.0	34	31	103.5	16	13.0
R3582.R025	Right	25	94.0	M24 x 2*	64	34.0	41	38	126.5	20	17.0
R3582.R030	Right	30	110.0	M30 x 2*	73	41.0	48	47	146.5	22	19.0
R3582.L004	Left	4	22.5	M4	15	8.0	9.2	9.5	30.0	5	3.5
R3582.L005	Left	5	30.0	M5	19	9.0	11	12	39.5	6	4.4
R3582.L006	Left	6	30.0	M6	21	11.0	13	12	40.5	6	4.4
R3582.L008	Left	8	36.0	M8	24	13.0	16	16	48.0	8	6.0
R3582.L010	Left	10	43.0	M10	29	15.0	19	18	57.5	9	7.0
R3582.L011	Left	10	43.0	M10 x 1,25*	29	15.0	19	18	57.5	9	7.0
R3582.L012	Left	12	50.0	M12	34	18.0	22	20	67.0	10	8.0
R3582.L013	Left	12	50.0	M12 x 1,25*	34	18.0	22	20	67.0	10	8.0
R3582.L015	Left	15	61.0	M14	40	21.0	26	26	81.0	12	10.0
R3582.L017	Left	17	67.0	M16	46	24.0	30	27	90.0	14	11.0
R3582.L018	Left	17	67.0	M16 x 1,5*	46	24.0	30	27	90.0	14	11.0
R3582.L020	Left	20	77.0	M20 x 1,5*	53	27.0	34	31	103.5	16	13.0
R3582.L021	Left	20	77.0	M20 x 2,5	53	27.0	34	31	103.5	16	13.0
R3582.L025	Left	25	94.0	M24 x 2*	64	34.0	41	38	126.5	20	17.0



Order No.	Thread hand	d ₁ tol. ±10	l ₁	d ₂	d ₃	d ₄	d ₅	l ₂	l ₃	w ₁	w ₂
R3582.L030	Left	30	110.0	M30 x 2*	73	41.0	48	47	146.5	22	19.0

ROD ENDS

Order No.	A/F	α°	Static strength (long term) N max.	Radial load (short term) N max.	Radial load (long term) N max.	Static strength (short term) N max.	Thread depth min.	Torque inside thread Nm max.	Torque through ball Nm max.
R3582.R004	08	16.5	400	100	50	800	7	0.4	2.0
R3582.R005	09	16.5	650	150	75	1300	8	0.5	2.0
R3582.R006	11	13.5	750	200	100	1500	8	1.5	2.5
R3582.R008	14	12	1000	450	225	2000	11	5.0	7.0
R3582.R010	17	12	1150	500	250	2300	13	15.0	14.0
R3582.R011	17	12	1150	500	250	2300	13	6.0	14.0
R3582.R012	19	10.5	1650	550	275	3300	14	20.0	25.0
R3582.R013	19	10.5	1650	550	275	3300	14	15.0	25.0
R3582.R015	22	10.5	2400	800	400	4800	18	25.0	30.0
R3582.R017	27	9	2650	1100	550	5300	19	30.0	35.0
R3582.R018	27	9	2650	1100	550	5300	19	27.5	35.0
R3582.R020	30	8	3600	1800	900	7200	22	60.0	40.0
R3582.R021	30	8	3600	1800	900	7200	22	60.0	40.0
R3582.R025	36	8	5000	2600	1300	10000	27	115.0	55.0
R3582.R030	41	6.5	5250	3000	1300	10500	33	130.0	70.0
R3582.L004	08	16.5	400	100	50	800	7	0.4	2.0
R3582.L005	09	16.5	650	150	75	1300	8	0.5	2.0
R3582.L006	11	13.5	750	200	100	1500	8	1.5	2.5
R3582.L008	14	12	1000	450	225	2000	11	5.0	7.0
R3582.L010	17	12	1150	500	250	2300	13	15.0	14.0
R3582.L011	17	12	1150	500	250	2300	13	6.0	14.0
R3582.L012	19	10.5	1650	550	275	3300	14	20.0	25.0
R3582.L013	19	10.5	1650	550	275	3300	14	15.0	25.0
R3582.L015	22	10.5	2400	800	400	4800	18	25.0	30.0
R3582.L017	27	9	2650	1100	550	5300	19	30.0	35.0
R3582.L018	27	9	2650	1100	550	5300	19	27.5	35.0
R3582.L020	30	8	3600	1800	900	7200	22	60.0	40.0
R3582.L021	30	8	3600	1800	900	7200	22	60.0	40.0
R3582.L025	36	8	5000	2600	1300	10000	27	115.0	55.0
R3582.L030	41	6.5	5250	3000	1300	10500	33	130.0	70.0

All of our rod ends incorporate either a plain spherical bearing, ball bearing, or roller bearing. Below is an overview of each type.

Plain spherical bearings

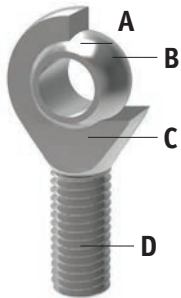

- A** Made from Polyamid-PTFE-fibreglass-compound, maintenance free, absorbs any foreign particles
- B** Ball made of bearing steel, hardened, ground, polished and hard chromium plated, ensures reliable corrosion protection
- C** No clearance - radial clearance 0-10µm
- D** All rod ends housings made of forged steel, tempered, extremely high loads resistant

Ball and roller bearings

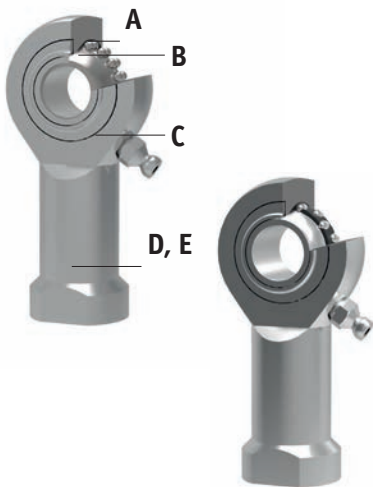

- A** Radial clearance: 10-30µm, low friction
- B** Inner ring made of bearing steel, hardened ball grooves polished
- C** Shields on both sides protect against rough dirt penetration
- D** All rod ends housings are made of forged steel, case hardened bearing race
- E** Low maintenance due to long-term greasing, especially suitable for high speed large swiveling angles or rotating movements

Rod ends and water



Stainless steel versions

Most of our rod ends are available in stainless steel as standard

High grade AISI 316 stainless steel available on request

Rod Ends from Automation Components

ROD ENDS



Rod ends with integral maintenance-free spherical plain bearings

In many cases heavy-duty rod ends with integral spherical plain bearings are most often used. They are above all used for small swivelling or tilting movements at low speeds. They stand out for their high load capacity and can also be used for shock-like loads. The rod end ball slides on a plastic bearing shell consisting of a glass fibre-filled nylon/teflon compound. This design assures a maintenance-free rod end. Heavy-duty plain bearing rod ends have slight initial movement friction and virtually no clearance. The plastic material used has another advantage in that it can absorb many foreign particles so that no damage can occur. The balls of heavy-duty rod ends with integral spherical plain bearings are hard chrome plated. This reliable corrosion protection ensures that the function of the rod end will not be affected by a corroded ball surface under humid operating conditions.

Rod ends with integral ball bearings

This design is especially suitable for high speeds, large swivelling angles or rotating movements with relatively low or medium loads. Prominent technical features are the low bearing friction, long-time greasing as well as the sealing against some dirt penetration (by means of shields on both sides). Under normal operating conditions the rod ends are maintenance-free.

Greasing nipples are provided for lubrication in case of rough operations and maximum loads. To avoid incompatibility with the production lubrication, we recommend lubrication with a calcium-complex-soap-grease. A special heat treatment procedure gives the rod end housing a raceway hardness adapted to the antifriction bearing, ensuring at the same time high stability with changing loads.

Rod ends with integral roller bearings

This design based on the structure of a self-aligning roller bearing is preferably used for high speed, large tilting angles or rotating movements under high loads. Compared to rod ends with ball bearings, rod ends with self-aligning roller bearings have essentially higher basic load ratings. This design is equipped with a cage to minimise the rolling friction and heat build-up. These rod ends, with long-time lubrication are under normal operating conditions maintenance-free.

Greasing nipples are provided for lubrication in case of rough operations and maximum loads. To avoid incompatibility with the production lubrication, we recommend lubricating with a calcium-complex-soap-grease.

Shields on both sides limit dirt particles from penetrating into the bearing. The rod ends with roller bearings are, subjected to a special heat treatment to obtain a raceway hardness adapted to the antifriction bearings, ensuring at the same time a high stability with changing loads.



Static load capacity C_0 (plain bearings)

The static load capacity C_0 is the radially acting static load which does not cause any permanent deformation of the components when the spherical bearing or rod end is stationary, (i.e. the load condition without pivoting, swivelling or tilting movements).

It is also a precondition here that the operating temperature must be at normal room temperature and the surrounding components must possess sufficient stability.

The values specified in the tables are determined by static tension tests on a representative number of series components at 20°C normal room temperature. The static load capacity may vary with lower or higher temperature depending on the material.

In the case of all rod ends with plain bearings, the static load rating refers to the maximum permissible static load of the rod end housing in a tensile direction up to which no permanent deformation occurs at the weakest housing cross-section. The value in the product tables has a safety factor of 1.2 times the tensile strength of the rod ends housing material.

Static load capacity C_0 (roller and ball bearings)

For our rod ends with roller and ball bearings, the static load rating is the load at which the bearing can operate at room temperature without its performance being impaired as a result of deformations, fracture, or damage to the sliding contact surfaces (max 1/10,000th of the ball diameter).

Dynamic load capacity C (plain bearings)

Dynamic load ratings serve as values for calculation of the service life of dynamically-loaded spherical bearings and rod ends. The values themselves do not provide any information about the effective dynamic load capacity of the spherical bearing or rod end. To obtain this information, it is necessary to take into account the additional influencing factors such as load type, swivel or tilt angle, speed characteristic, max. permitted bearing clearance, max. permitted bearing friction, lubrication conditions and temperature, etc.

Dynamic load capacities depend on the definition used to calculate them. Comparison of values is not always possible owing to the different definitions used by various manufacturers, and because the load capacities are often determined under completely different test conditions.

Dynamic load capacity C (roller and ball bearings)

For our rod ends with roller and ball bearings, the dynamic load capacity is the load at which 90% of a large quantity of identical rod ends reach 1 million revolutions before they fail (due to fatigue of the rolling surfaces).



Low cost rod ends load ratings

The ultimate radial static load rating is measured as the failure point when a load is increasingly applied to a pin through the rod end's bore and pulled straight up while the rod end is held in place. Note that the actual rating is determined by calculating the lowest of the following three values:

1: Raceway material comprehensive strength (R value):

$$R = E \times T \times X$$

2: Rod end head strength (H value, cartridge type construction):

$$H = \left[\left(\frac{T}{2} \sqrt{D^2 - T^2} \right) + \left(\frac{D^2}{2} \times \sin^{-1} \frac{T}{2} \right) - (\text{O.D. of Bearing} \times T) \right] \times X$$

Angle of $\frac{T}{2}$ expressed in radians

3: Shank strength (S Value) male threaded rod end:

$$S = [(\text{root diameter of thread}^2 \times .78) - (N^2 \times .78)] \times X$$

female threaded rod end:

$$S_2 = [(J^2 \times .78) + (\text{major diameter of thread} \times .78)] \times X$$

- Where: E = Ball diameter
 T = Housing width
 X = Allowable stress
 D = Head diameter
 N = Diameter of drilled hole in shank of male rod end
 J = Shank diameter of female rod end

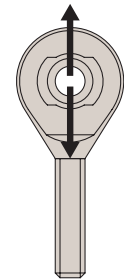

The axial static load capacity is measured as the force required to cause failure via a load parallel to the axis of the bore. Depending on the material types and construction methods, the ultimate axial load is generally 10-20% of the ultimate radial static load. The formula does not account for the bending of the shank due to a moment of force, nor the strength of the stake in cartridge-type construction.

Axial strength (A Value):

$$A = .78 [(E + .176T)^2 - E^2] \times X$$

- Where: X = Allowable stress (see table below)
 E = Ball diameter
 T = Housing width

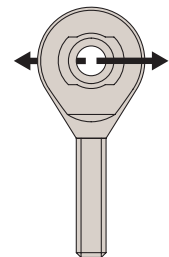

Material	Allowable stress (PSI)
300 Series Stainless Steel	35,000
Low Carbon Steel	52,000

Rod Ends from Automation Components

ROD ENDS